



**GOVERNMENT OF ODISHA
FOREST DEPARTMENT
PURI WILDLIFE DIVISION**

STANDARD BIDDING DOCUMENT

**Procurement of Building Works on
Turnkey Basis (Architectural planning with
Design & Execution)**

GOVERNMENT OF ODISHA

CONSTRUCTION OF DIVISIONAL FOREST OFFICE INCLUDING BOUNDARY WALL, PURI WILDLIFE DIVISION IN THE PURI DISTRICT IN THE STATE OF ODISHA ON TURNKEY BASIS.

COMPETITIVE BIDDING

(BUILDING WORKS ON TURNKEY BASIS (ARCHITECTURAL PLANNING WITH DESIGN & EXECUTION))

| | |
|---|--|
| NAME OF WORK | : Construction of Divisional Forest Office including boundary wall, Puri Wildlife Division in Puri District in the State of Odisha on Turnkey Basis. |
| PERIOD OF SALE OF BIDDING DOCUMENT | : FROM Dt.17.12.2024 TO Dt.30.12.2024 up to 5.00PM |
| TIME AND DATE OF PRE-BID CONFERENCE | : Dt.24.12.2024 at 11:00 AM |
| LAST DATE AND TIME FOR RECEIPT OF BIDS | : Dt.30.12.2024 at 5:00 PM |
| *TIME AND DATE OF OPENING TECHNICAL BIDS | : Dt.31.12.2024 at 11:30 AM |
| TIME AND DATE OF CONCEPT DRAWING PRESENTATION | : To be notified later. |
| *TIME AND DATE OF OPENING FINANCIAL BIDS | : To be notified later |
| PLACE OF OPENING OF BIDS | : Office of the Divisional Forest Officer, Chakrathirtha Road, Puri |
| OFFICER INVITING BIDS | : Divisional Forest Officer, Puri Wildlife Division, Puri |

INVITATION FOR BID
(IFB)



OFFICE OF THE DIVISIONAL FOREST OFFICER
PURI WILDLIFE DIVISION PURI

Ltr.No-8141 Puri, the

16thDecember 2024.

INVITATIONS FOR BIDS (IFB)
COMPETITIVE BIDDING
Bid Identification No. – 12/ 2024-25

1. The [Divisional Forest Officer, Puri Wildlife Division](#) on behalf of Governor of Odisha invites bids from [reputed Indian firms](#) registered with the State Government and bidders of equivalent Grade / Class registered with Central Government / MES / Railways for the building works detailed in the table below on turnkey basis (i.e. Architectural planning with design & execution).

2.

| Sl | Name of the building | Class of Contractor | Bid security (₹ -) | Cost of bid documents | Period of completion |
|----|---|----------------------|-----------------------|-----------------------|--------------------------|
| 1 | 2 | 3 | 4 | 5 | 6 |
| 1. | Construction of Divisional Forest Office, Puri Wildlife Division in Puri District in the State of Odisha on Turnkey Basis | "A" Class Contractor | 3,13,000/- | 10,000/- | 12 (Twelve) months |

3. The Bidders have to participate in ONLINE bidding only. Further details can be seen from the web site: <https://tendersodisha.gov.in>. and <http://www.puri.odisha.gov.in> Any addendum / corrigendum / cancellation of tender can also be seen in the said web site only.
4. The Bid documents will be available for downloading in the website: <https://tendersodisha.gov.in> from [Dt.17.12.2024 at 9:00AM](#).
5. A pre-bid meeting shall be held on [Dt. 24.12.2024 at 11:00 AM](#) at the [Conference Hall of Office of the Divisional Forest Officer, Puri Wildlife Division, Puri](#)
6. Bids shall be received online on or before [Dt. 30.12.2024 up to 5:00 PM](#). The bidder must possess compatible Digital Signature Certificate (DSC) of Class-II or Class-III.
Bids received online on due date and time shall be opened at [Dt. 31.12.2024 at 11:30 AM](#) in the Office of the [Divisional Forest Officer, Puri Wildlife Division, Puri](#).
7. Other details can be seen in the bidding documents.
8. The authority reserves the right to cancel any or all bids without assigning any reason.

Divisional Forest Officer,
Puri Wildlife Division, Puri

Memo No. 8142 Dt 16.12.2024

Copy forwarded to the Deputy Director (Advertisement) & Deputy Secretary to Govt., I. & P.R. Dept., Odisha, Bhubaneswar with a request to get the Invitation for Bids (IFB) published in two nos. of leading Odia Daily and **one** nos. of National English Daily Newspapers at an early date for wide circulation.

Since the date of receipt of Bids for the work starts from **dt. 17.12.2024**, it is requested that the Invitation for Bids may be published prior to **dt. 17.12.2024**.

Complementary copy of the Newspapers publishing invitation for Bids (IFB) may be sent to this office for reference and record. The approximately cost of the project is **₹ 3.13 Crore**

Encl : As above

Divisional Forest Officer,
Puri Wildlife Division, Puri

Memo No. 8143 **Dt.16.12.2024**

Copy along with enclosure forwarded to the Conservator of Forests (IT &GIS), O/o the Principal Chief Conservator of Forest & HoFF, Odisha Bhubaneswar for favour of Kind information and necessary action. He is requested to upload the above notice in the website of PCCF, Odisha i.e [www. Odishaforest.in](http://www.Odishaforest.in).

Encl : As above

Divisional Forest Officer,
Puri Wildlife Division, Puri

Memo No. 8144 **Dt.16.12.2024**

Copy forwarded to the Regional Chief Conservator of Forests, Bhubaneswar for favour of Kind information and necessary action.

Divisional Forest Officer,
Puri Wildlife Division, Puri

Memo No. 8145 **Dt.16.12.2024**

Copy forwarded to the Dist E-governance manager, Puri for faovur of Kind information and necessary action. He is requested to upload the above notice in the Dist NIC portal for wide Publication.

Divisional Forest Officer,
Puri Wildlife Division, Puri

Memo No. 8146 **Dt.16.12.2024**

Copy forwarded to the All Divisional Forest Officers (T & WL) with a request for notice boards for wide circulation.

Divisional Forest Officer,
Puri Wildlife Division, Puri

Memo No.8147 **Dt.16.12.2024**

Copy forwarded to the Range Officer, Balukhanda Wildlife range for information and wide circulation.

Divisional Forest Officer,
Puri Wildlife Division, Puri

SECTION 1

INSTRUCTION TO BIDDERS **(ITB)**

A. General Instructions

1. Scope of Bid :

- 1.1** The **Divisional Forest Officer, Puri Wildlife Division**, State of Odisha invites bids for the building works “**Construction of Divisional Forest Office including boundary wall, Puri Wildlife Division in Puri District in the State of Odisha on Turnkey Basis**” with design & execution.
- 1.2** The successful bidder shall be expected to complete the works by the intended completion date specified in the Contract.
- 1.3.** Throughout these bidding documents, the terms 'bid' and 'tender' and their derivatives (bidder, tenderer, bid/ tender, bidding/ tendering, etc.) are synonymous. Contractor means the selected bidder for the work.

2. Source of Funds:

The expenditure on this project shall be met from the fund allotted to the Divisional Forest Officer, Puri Wildlife Division by the o/o PCCF & HoFF, Odisha, Bhubaneswar.

3. Eligible Bidders:

- 3.1.** This Invitation for Bids is open to all bidders registered with the Government of Odisha or other State Governments / Government of India / MES / Railways for execution of Civil works in general and Road & building work in particular. Bidders are advised to note the minimum qualification criteria specified in the “Instruction to Bidders” to qualify for the award of contract.
- 3.2.** All bidders shall provide in Section 2, Forms of Bid and Qualification Information.
- 3.3** Bidders shall not be under a declaration of ineligibility for corrupt and fraudulent practices.

4. Qualification of the Bidder:

- 4.1** All bidders shall provide Forms of Bid and Qualification Information under Section 2, a preliminary description of the proposed work method and schedule, including drawings and charts, as necessary. The proposed methodology should include programme of construction backed with equipment planning and deployment duly supported with broad calculations and quality – assurance procedures proposed to be adopted justifying their capability of execution and completion of work as per technical specifications, within stipulated period of completion.
- 4.2** If the Employer has not undertaken prequalification of potential bidders, all bidders shall include the following information and documents with their bids in Section 2:
 - (a) Copies of original documents defining the constitution or legal status, place of registration, and principal place of business, written power of attorney of the signatory of the Bid to commit the Bidder;
 - (b) Financial Turnover of the bidder during last **five** financial years.
 - (c) Experience in building project works and size for each of the last **seven** financial years, and details of works under way or contractually committed and clients who may be contacted for further information on those contracts;
 - (d) Major items of construction equipment proposed to carry out the Contract;

- (e) Qualifications and experience of key site management and technical personnel proposed for the Contract;
- (f) Reports on the financial standing of the Bidder, such as profit and loss statements and auditor's reports for the past five financial years;
- (g) Evidence of adequacy of working capital for this contract (access to line (s) of credit and availability of other financial resources);
- (h) Authority to seek references from the Bidder's bankers;
- (i) Information regarding any litigation or arbitration resulting from contracts executed by the bidder in the last five years or currently under execution. The information shall include the names of the parties concerned, the disputed amount, cause of litigation, and matter in dispute;
- (j) Proposals for subcontracting components of the Works amounting to more than 20 percent of the Bid Price (for each, the qualifications and experience of the identified sub-contractor in the relevant field should be annexed); and
- (k) The proposed methodology and program of construction, backed with equipment planning and deployment, duly supported with broad calculations and quality control procedures proposed to be adopted, justifying their capability of execution and completion of the work as per technical specifications within the stipulated period of completion as per milestones as mentioned in the Contract data.

4.3 Bids from Joint venture of firms are acceptable:

- 4.3.1 For determining the eligibility of Applicants for their qualification hereunder, the following shall apply:
- (a) The Applicant for qualification may be a single entity or a group of entities (the "Joint Venture"), coming together to implement the Project. However, no applicant applying individually or as a member of a Joint Venture, as the case may be, can be member of another Applicant. The term Applicant used herein would apply to both a single entity and a Joint Venture.
 - (b) An Applicant may be a company incorporated under the Indian Companies Act, 1956 or a combination of companies with a formal intent to enter into a Joint Venture agreement or under an existing agreement to form a Joint Venture. A Joint Venture shall be eligible for consideration subject to the conditions set out in Clause 4.3.6 below.
 - (c) An Applicant shall not have a conflict of interest (the "Conflict of Interest") that affects the Bidding Process. Any Applicant found to have a Conflict of Interest shall be disqualified. An Applicant shall be deemed to have a Conflict of Interest affecting the Bidding Process, if:
 - (i) the Applicant, its Member or any constituent thereof and any other Applicant, its Member or any constituent thereof have common controlling shareholders or other ownership interest; provided that this disqualification shall not apply in cases where the direct or indirect shareholding of an Applicant, its Member thereof (or any shareholder thereof having a shareholding of more than 5 per cent of the paid up and subscribed share capital of such Applicant, Member, as the case may be), in the other Applicant, its Member is less than 5 per cent of the subscribed and paid up equity share capital thereof; provided further that this disqualification shall not apply to any ownership by a bank, insurance company, pension fund or a public financial institution referred to in section 4A of the Companies Act 1956. For the purposes of this Clause 4.3.1(c), indirect shareholding held through one or more intermediate persons shall be computed as follows: (aa) where any intermediary is controlled by a person through management control or otherwise, the entire shareholding held by such controlled intermediary in any other person (the "Subject Person") shall be taken into account for computing the shareholding of such controlling person in the Subject Person; and (bb) subject always to sub-clause (aa) above, where a person does not exercise control over an intermediary, which has shareholding in the Subject Person, the computation of indirect shareholding of such person in the Subject

Person shall be undertaken on a proportionate basis; provided, however, that no such shareholding shall be reckoned under this sub-clause (bb) if the shareholding of such person in the intermediary is less than 26% of the subscribed and paid-up equity shareholding of such intermediary; or

- (ii) a constituent of such Applicant is also a constituent of another Applicant; or
 - (iii) such Applicant receives or has received any direct or indirect subsidy, grant, concessional loan or subordinated debt from any other Applicant, or has provided any such subsidy, grant, concessional loan or subordinated debt to any other Applicant, its member thereof; or
 - (iv) such Applicant has the same legal representative for purposes of this Application as any other Applicant; or
 - (v) such Applicant has a relationship with another Applicant, directly or through common third party/ parties, that puts either or both of them in a position to have access to each other's information about, or to influence the Application of either or each other; or
 - (vi) such Applicant has participated as a consultant to the Authority in the preparation of any documents, design or technical specifications of the Project.
- (d) An Applicant shall be liable for disqualification if any legal, financial or technical adviser of the Authority in relation to the Project is engaged by the Applicant, or any of its Members, as the case may be, in any manner for matters related to or incidental to the Project. For the avoidance of doubt, this disqualification shall not apply where such adviser was engaged by the Applicant, its Member in the past but its assignment expired or was terminated 6 (six) months prior to the date of issue of the NIT. Nor will this disqualification apply where such adviser is engaged after a period of 3 (three) years from the date of commercial operation of the Project.

Explanation: In case an Applicant is a Joint Venture, then the term Applicant as used in this Clause 4.3.1, shall include each Member of such Joint Venture.

- (e) Other eligibility conditions shall include:

Bidders who meet the minimum qualification criteria will be qualified only if their available bid capacity is more than the total bid value. The available bid capacity will be calculated as under:

Assessed Available Bid capacity = $(A * N * 2 - B)$

where

A = Maximum value of civil engineering works in respect of Turnkey Projects executed in any one year during the last Five years (updated to the price level of the year as indicated in clause 4.6) taking into account the completed as well as works in progress.

N = Number of years prescribed for completion of the works for which bids are invited.

B = Value (updated to the price level of the year indicated in Clause-4.4 A-II of section-I, ITB) of existing commitments and on-going works to be completed during the next Two Years (period of completion of the works for which bids are invited).

Note: The statement showing the value of existing commitments and on-going works as well as the stipulated period completion remaining for each of the works listed should be countersigned by the Engineer in the charge, not below the rank of an Executive Engineer or equivalent.

4.3.2 To be eligible for qualification, an Applicant, shall fulfil the following conditions of eligibility:

(A) Technical Capacity: For demonstrating technical capacity and experience (the "Technical Capacity"), the Applicant shall, over the past 5 (five) financial years preceding the Application Due Date, have received payments for construction of Eligible Project(s), or has undertaken construction works by itself in a Building project, such that the sum total thereof is more than **Rs. 7.825 crore (Rs. Seven Crore Eighty Two lakh Five Thousand only)**(the "Threshold Technical capacity")
Provided that at least one similar work of 50% of Estimated Project Cost shall have been completed from the Eligible Projects as per Clause 4.4A. II.

(B) Financial Capacity: The Applicant shall have a minimum Net Worth (the "Financial Capacity") of **Rs. 31 Lakhs (Rs Thirty-One Lakh only)** at the close of the preceding financial year.

4.3.3 In case of a Joint Venture, the Threshold Technical Capacity and Financial Capacity of all the Members of Joint Venture would be taken into account for satisfying the above conditions of eligibility. Further, Lead Member shall meet at least 60% requirement of Technical and Financial Capacity required as per Clause 4.3.2 (A) & (B) and each of other JV members shall meet at least 40% requirement of Technical and Financial capacity as per Clause 4.3.2 (A) & (B). For avoidance of doubt, it is further clarified that the Joint Venture must collectively and individually satisfy the above qualification criteria.

4.3.4 The Applicant shall enclose with its application, to be submitted as per the format at Appendix-I, complete with its Annexes, the following:

- (i) Certificate(s) from its statutory auditors or the concerned client(s) stating the payments received or in case of a (Turnkey) project, the construction carried out by itself, during the past 5 years, in respect of the Eligible Projects. In case a particular job/ contract has been jointly executed by the Applicant (as part of a Joint Venture), it should further support its claim for the payments received or construction carried out by itself in (Turnkey) Projects as applicable the share in work done for that particular job/ contract by producing a certificate from its statutory auditor or the client; and
- (ii) certificate(s) from its statutory auditors specifying the net worth of the Applicant, as at the close of the preceding financial year, and also specifying that the methodology adopted for calculating such net worth conforms to the provisions of this Clause 4.3.4 (ii). For the purposes of this Bid, net worth (the "Net Worth") shall mean the sum of subscribed and paid-up equity and reserves from which shall be deducted the sum of revaluation reserves, miscellaneous expenditure not written off and reserves not available for distribution to equity shareholders.

| |
|---|
| 1 This amount should be equivalent to two and half times of the estimated cost of the project for which bids are being invited. |
| 2 Net worth has been adopted as the criterion for assessing financial capacity since it is a comprehensive indication of the financial strength of the Applicant. |
| 3 This amount should be 10% (Ten percent) of the Estimated Cost of the Project for which bids are being invited. |
| § In case duly certified audited annual financial statements containing explicitly the requisite details are provided, a separate certification by statutory auditors would not be necessary in respect of Clause 4.3.4 (i). In jurisdictions that do not have statutory auditors, the firm of auditors which audits the annual accounts of the Applicant may provide the certificates required under this Bid. |

4.3.5 The Applicant should submit a Power of Attorney as per the format at Appendix-I, authorising the signatory of the Application to commit the Applicant. In the case of a Joint Venture, the Members should submit a Power of Attorney in favour of the Lead Member as per format at Appendix-II.

4.3.6 In case the Applicant is a Joint Venture, it shall comply with the following additional requirements:

- (a) Number of members in a Joint Venture shall not exceed 2 (Two);
- (b) subject to the provisions of clause (a) above, the Application should contain the information required for each Member of the Joint Venture;
- (c) Members of the Joint Venture shall nominate one member as the lead member (the "Lead Member"). Lead Member shall meet at least 60% requirement of Technical and Financial Capacity required as per Clause 4.3.2 (A) & (B). The nomination(s) shall be supported by a Power of Attorney, as per the format at Appendix-III, signed by all the other Members of the Joint Venture;
- (d) the Application should include a brief description of the roles and responsibilities of individual members, particularly with reference to financial, technical and defect liability obligations;
- (e) an individual Applicant cannot at the same time be member of a Joint Venture applying for qualification. Further, a member of a particular Applicant Joint Venture cannot be member of any other Applicant Joint Venture applying for qualification;

- (f) the Lead Member shall itself undertake and perform at least 50 (Fifty) per cent of the total Project.
- (g) members of the Joint Venture shall have entered into a binding Joint Bidding Agreement, substantially in the form specified at Appendix-III (the "Jt. Bidding Agreement"), for the purpose of making the Application and submitting a Bid in the event of being qualified. The Jt. Bidding Agreement, to be submitted along with the Application, shall, inter alia:
 - (i) convey the commitment(s) of the Lead Member in accordance with this SBD, in case the contract to undertake the Project is awarded to the Joint Venture;
 - (ii) clearly outline the proposed roles and responsibilities, if any, of each member;
 - (iii) commit the approximate share of work to be undertaken by each member;
 - (iv) include a statement to the effect that all members of the Joint Venture shall be liable jointly and severally for all obligations of the Contractor in relation to the Project until the completion of the Project (the "Defects Liability Period") is achieved in accordance with the Turnkey Contract; and
- (h) except as provided under this Turnkey Bidding Documents, there shall not be any amendment to the Jt. Bidding Agreement.

4.3.7 Any entity which has been barred by the Central/State Government, or any entity controlled by it, from participating in any project, and the bar subsists as on the date of Application, would not be eligible to submit an application, either individually or as member of a Joint Venture.

4.3.8 An Applicant including any Member should, in the last 3 (three) years, have neither failed to perform on any contract, as evidenced by imposition of a penalty by an arbitral or judicial authority or a judicial pronouncement or arbitration award against the Applicant or Member, as the case may be, nor has been expelled from any project or contract by any public entity nor have had any contract terminated by any public entity for breach by such Applicant or Member.

4.3.8.1 The Applicant including any Member may provide details of all their on-going projects along with stage of litigation, if so, against the Authority/Governments.

4.3.8.2 The Applicant including any member may also provide details of on-going process of blacklisting if so, under any contract with Authority/Government.

4.4A :-I Only Reputed Indian firms [It is meant for the Indian Firm having reputation in the specific area of operation for which tender is being invited as defined in Note under Rule-2, Appendix-VIII of OPWD Code Vol-II] are allowed to apply for this Project.

II Experience of following having successfully completed any one of the following building works in India on **Design & Build Basis** during last 7 years ending 31.03.2024. The Value of executed work shall be brought to current actual value at simple rate of 7% per annum

One building project of **Rs. 3.13 Crores**

Or

Two building projects of **Rs.2.1 Crores**

Or

Three building projects of **Rs. 1.565 Crores**

In addition, the Bidder should satisfy the following:

- a) Bidder should submit completion certificate for central / state government projects. For private sector projects, completion certificate with TDS shall be submitted.

- III** Should have an annual average turnover of **Rs. 7.825 Crore** certified by chartered accountant during the last five financial years.
- IV** Should have latest bank solvency certificate for amount of **at least (50% of the bid value)** in the current financial year. Certificate should have been issued after 31.03.2024 and clearly state that Banker shall be extending necessary financial support required for execution of the subject work.
- V** Should have valid GST number /PAN number.
- VI** Should not have incurred any major loss during last 3 financial years.
- VII** Joint venture / Consortium / Sub Consultancy are permitted to bid.
- VIII Overseas Experience of the bidder shall not be considered.**
- IX** Preference shall be given to applicants who has in-house design expertise and in-house MEP execution capabilities
- X** The Firm should be making profit during each of the last three financial years, ending on March 31, 2024. Financial data for previous 5 years shall be submitted as per format in Annexure 3.
- XI** The bidding capacity of the contractor should be equal to or more than the estimated cost of the work. The bidding capacity shall be worked out by the formula.
- Bidding Capacity = (A x N x 2) - B
- Where:
- a) A = Maximum value of construction works executed in any one year during the last 7 years
- b) N = Number of years prescribed for completion for which the bid has been invited
- c) B = Value of existing commitments and on-going works to be completed during the period of completion of work for which the bids have been invited
- XII** Bidders must furnish with their bid, a detailed construction, planning and methodology supported with layout and necessary drawings and detail calculations to allow the Employer to review their proposals. that banker shall be extending necessary financial support required for execution of the subject work.

4.4B. Each bidder should further demonstrate: -

A) Availability (either owned or leased) of the following key and critical equipment for this work:

| Sl. No. | List of plants and equipments | Requirement [insert as required for the project] |
|----------------|--|---|
| 1. | Cement Concrete batch mix plant arrangement (with capacity of 40-60 Tph) | 1 nos. |
| 2. | Vibrator / Equipment | 2 nos. |
| 3. | Excavator | 1 nos. |
| 4. | Complete steel staging and shuttering materials. | 5,000 Sqft. |
| 5. | Field Testing equipment | 2 sets |
| 6. | Truck & Tipper | 2 nos. |
| 7. | Modern sophisticated theodolite with leveling machine | 1 no. |
| 8. | Hoisting crane upto 22m height | 1 no. |
| 9. | Truck mounted transit mixer with concrete pump | 1 no. |
| 10. | Pile driving machine | 1 no. |
| 11. | Construction Elevator | 1 no. |
| | | |

Note: Based on the preliminary studies carried out by the department, an indicative list of major equipment and their quantity to attain the completion of works are shown in the above list.

- B) The bidders should, however, undertake their own studies and furnish with their bid, a detailed construction planning and methodology supported with layout and necessary drawings and detail calculations to allow the employer to review their proposals. The numbers, types and capacities of each plant/equipment shall be shown in the proposals along with the cycle time for each operation for the given production capacity to match the requirements.
- C) Liquid assets and / or availability of credit facilities of not less than the amount of **Rs. 1.0 crores** (Credit lines / letter of Credit / Certificate from banks for meeting the fund requirements etc. – usually the equivalent of the estimated cash flow for three months in peak construction period)

4.4C. To qualify for a package of contracts made up of this and other contracts for which bids are invited in the IFB, the bidder must demonstrate having experience and resources sufficient to meet the aggregate of the qualifying criteria for the individual contracts.

4.5 Sub-contractors' experience and resources shall not be taken into account in determining the bidder's compliance with the qualifying criteria

4.6 Bidders who meet the minimum qualification criteria will be qualified only if their available bid capacity is more than the total bid value. The available bid capacity will be calculated as under:

$$\text{Assessed Available Bid capacity} = (A \times N \times 2) - B$$

Where

A = Maximum value of civil engineering works executed in any one financial year during the last five financial years (updated to bid invitation year price level) taking into account the completed as well as works in progress.

N = Number of years prescribed for completion of the works for which bids are invited.

B = Value (updated to the price level on the year in which bids are received) of existing commitments and on-going works to be completed during the next 24 calendar months.

Note: The statements showing the value of existing commitments and on-going works as well as the stipulated period of completion remaining for each of the works listed should be countersigned by the Engineer in charge, not below the rank of an Executive Engineer or equivalent.

4.7 Even though the bidders meet the above qualifying criteria, they are subject to be disqualified if they have:

- Made any misleading or false representations in the forms, statements and attachments submitted in proof of the qualification requirements; and/or
- Record of poor performance such as abandoning the works, not properly completing the contract, inordinate delays in completion, litigation history, or financial failures etc.; and / or
- Participated in the previous bidding for the same work and had quoted unreasonably high bid prices and could not furnish rational justification to the employer.

5. One Bid per Bidder:

Each bidder shall submit only one bid for one package. A bidder who submits or participates in more than one Bid (other than as a subcontractor or in cases of alternatives that have been permitted or requested) will cause all the proposals with the Bidder's participation to be disqualified.

6. Cost of Bidding:

The bidder shall bear all costs associated with the preparation and submission of his Bid, and the Employer will in no case be responsible and liable for those costs.

7. Site visit

The Bidder, at the Bidder's own responsibility and risk is encouraged to visit and examine the Site of Works and its surroundings and obtain all information that may be necessary for preparing the Bid and entering into a contract for construction of the Works. The costs of visiting the Site shall be at the Bidder's own expense.

B. Bidding Documents

8. Content of Bidding Documents:

8.1 The set of bidding documents comprises the documents listed below and addenda issued in accordance with Clause 10:

| Section | Particulars | Volume No |
|---------|---|-----------|
| | Invitation for Bids | I |
| 1 | Instructions to Bidders | |
| 2 | Form of bid, Qualification Information, and other forms | |
| 3 | Conditions of Contract | |
| 4 | Contract data | |
| 5 | Technical Specifications | II |
| 6 | Securities and other forms | III |
| 7 | Drawings (Conceptual and broad specification, technical parameters) | IV |
| 8 | Terms of Reference (TOR) for design | |
| 9 | Project execution & supervision aspects, Contract Management Framework & payment schedule | |
| 10 | Documents to be furnished by bidder | V |

8.2. The Bidder shall download the above listed documents as listed under Volume I, II, III and IV and shall submit his bid after preparing the same in compliance to section 2 (refer clause 12)

8.3. The bidder shall be expected to examine carefully all instructions, conditions of contract, contract data, forms, terms, technical specifications, forms, annexes and drawings in the Bid Document. Failure to comply with the requirements of Bid Documents shall be at the bidder's own risk. Pursuant to clause 26 hereof, bids, which are not substantially responsive to the requirements of the Bid Documents, shall be rejected.

9. Clarification of Bidding Documents:

9.1 A prospective bidder requiring any clarification of the bidding documents may notify the Employer in writing or by cable (hereinafter "cable" includes telex, facsimile and e-mail) at the Employer's address indicated in the invitation to bid. The Employer will respond to any request for clarification, which he received earlier than 7 days prior to the deadline for submission of bids. Copies of the Employer's response will be forwarded to all purchasers of the bidding documents, including a description of the enquiry but without identifying its source.

9.2 Pre-bid meeting: -

- 9.2.1** The bidder or his official representative is invited to attend a pre-bid meeting which shall be held on **dt.24.12.2024 at 11:00 AM** at the office of Divisional Forest Officer, Puri Wildlife Division, Puri
- 9.2.2** The purpose of the meeting will be to clarify issues and to answer questions on any matter that may be raised at that stage.
- 9.2.3** The bidder is requested to submit any questions in writing to reach the Employer not later **than 3 days** before the meeting.
- 9.2.4** Minutes of the meeting, including the text of the questions raised (without identifying the source of enquiry) and the responses given will be transmitted without delay to all purchasers of the bidding documents. Any modification of the bidding documents listed in Sub-Clause 8.1 which may become necessary as a result of the pre-bid meeting shall be made by the Employer exclusively through the issue of an Addendum pursuant to Clause 10 and not through the minutes of the pre-bid meeting.
- 9.2.5** Non-attendance at the pre-bid meeting will not be a cause for disqualification of a bidder.

10. Amendment of Bidding Documents:

- 10.1** Before the deadline for submission of bids, the Employer may modify the bidding documents by issuing addenda.
- 10.2** Any addendum thus issued shall be part of the bidding documents and shall be communicated in writing or by cable/e-mail to all the purchasers of the bidding documents. Prospective bidders shall acknowledge receipt of each addendum in writing or by cable/e-mail to the Employer. The Employer will assume no responsibility for postal delays.
- 10.3** To give prospective bidders reasonable time of one month in which to take an addendum into account in preparing their bids, the Employer shall extend as necessary the deadline for submission of bids, in accordance with Sub-Clause 20.2 below.
- 10.4** The addendum shall also be available in official website as mentioned at Para 3 of IFB.
- 11.** The bidders who are qualified in the general assessment stated above have to give a presentation of concept design along with implementation programme.

C. Preparation of Bids

11. Language of the Bid:

All documents relating to the bid shall be in the English or Odia language.

12. Documents comprising the Bid:

The bid to be submitted by the bidder as Volume V of the bid document (refer Clause 8.1) shall be in two separate parts:

Cover-I: Shall be named "Technical Bid" and shall comprise (to be submitted in online & offline in sealed cover) of: -

- (i) Technical Bid (in the format indicated at Section 2);
- (ii) Bid Security in the form specified in Section 6 & cost of bid documents. (to be submitted separately in sealed cover)
- (iii) Qualification Information and supporting documents as specified in Section -2
- (iv) Certificates, undertakings, affidavits as specified in Section 2,
- (v) Undertaking that the bid shall remain valid for the period specified in Clause 15.1

Cover –II: Shall be named "Financial Bid" and shall comprise (to be submitted in online)

The Lump sum Price Bid;

Cover –III: To be submitted in sealed cover and shall comprise of: -

- i) Conceptual drawings, ii) Work programme,
- iii) Modalities of execution, iv) Specification

The sealed cover shall be received in the office of Divisional Forest Officer O/o , Puri Wildlife Division only during the office hours up to **5 working days from the last date of submission of the bid** (cover-I, cover-II) in online. The sealed covers (cover-III) submitted by post should reach and delivered in the above office within the stipulated date and time positively (**5 working days from the last date of submission of the bid**). The department will not be held responsible for any delay or loss or damage of the Bid documents during transit and in such events the bids stand rejected summarily. If cover-III is not received in due date and time the bid shall be declared non-responsive.

13. Bid Price:

13.1 The contract shall be for the whole work as described in Sub-Clause 1.1, **based on the Lump Sum Price Bid** submitted by the Bidder.

13.2 The bidder shall fill the total bid price as **Lump Sum Price** (both in figures and words) for all items of works as specified in the Bid document. Corrections, if any, shall be made by crossing out, initialing, dating and rewriting.

13.3 The prices tendered shall except in so far as it is otherwise, provided under the contract, include all constructional plant, labour, supervision, materials, erection maintenance, insurance, profit, taxes and duties & other levies together with all general risks, liabilities and obligations set out or implied in the contract.

13.4 The **lump sum bid price** quoted by the bidder shall be fixed for the duration of the Contract and shall not be subject to adjustment on any account.

14. Currencies of Bid and Payment:

The currency of bid and payment shall be quoted by the bidder entirely in Indian Rupees. All payments shall be made in Indian Rupees.

15. Bid Validity:

15.1 Bids shall remain valid for a period not less than (180) One Eighty days after the deadline date for bid submission specified in Clause 20. A bid valid for a shorter period shall be rejected by the Employer as non-responsive. In case of discrepancy in bid validity period between that given in the undertaking pursuant to Clause 12.1 (v) and the Form of Bid submitted by the bidder, the latter shall be deemed to stand corrected in accordance with the former and the bidder has to provide for any additional security that is required.

15.2. In exceptional circumstances, prior to expiry of the original time limit, the Employer may request that the bidders and the bidder may extend the period of validity for a specified additional period. The request and the bidders' responses shall be made in writing or by cable / e-mail. A bidder may refuse the request without forfeiting his bid security. A bidder agreeing to the request will not be required or permitted to modify his bid but will be required to extend the validity of his bid security for a period of the extension, and in compliance with Clause 16 in all respects.

16. Bid Security:

16.1 The Bidder shall furnish, as part of his Bid, a Bid security of an amount as shown in column 3 of the table of IFB for this particular work. Bid security in the shape such as Deposit Receipt of Scheduled Bank (Term Deposit Receipt) / Post Office Savings Bank Account / National Savings Certificate / Postal Office Time Deposit Account duly pledged in favour of the **Divisional Forest Officer, Puri Wildlife Division** is acceptable. The bidder has the option of furnishing Bid Security in the form of Bank Guarantee from a Nationalized Bank of India, **counter guaranteed by its branch at Puri.** Bidders owned or desirous to hire machineries or equipments but deployed outside the State are required to furnish **twice the above amount** as Bid Security in the shape as mentioned above.

16.2. Any bid not accompanied by an acceptable Bid Security and not secured as indicated in sub-clauses 16.1 shall be rejected by the Employer as non-responsive.

16.3. The Bid Security of unsuccessful bidders shall be returned within 28 days of the end of the bid validity period specified in sub-clause 15.1.

16.4. The Bid Security of the successful bidder shall be discharged when the bidder has signed the Agreement and furnished the required Performance Security

16.5 The Bid Security may be forfeited

(a) If the Bidder withdraws the Bid after Bid opening during the period of Bid validity;

(b) In the case of a successful Bidder, if the Bidder fails within the specified time limit to

(i) Sign the Agreement; or

(ii) Furnish the required Performance Security.

(iii) Deposit the required license fees with State Government to register itself as a appropriate Class contractor with Government of Odisha within 15 (fifteen) days of issue of Letter of Acceptance of Bid.

17. Alternative Proposals by Bidders:

Bidders shall submit offers as per his own estimate based on his own design & drawing but complying with the requirements of the bidding documents, including the basic technical design parameters and as per regulations of concerned Urban Development Authority, OECBC, specifications relevant IS Codes & NBC. **Conditional offer or alternative offers will not be considered further in the process of tender evaluation.**

18. Format and Signing of Bid:

18.1 The bidder shall submit one set of the bid comprising the documents as described in clause-12 of ITB.

18.2. The Bid shall be typed or written in indelible ink and shall be signed by a person or persons duly authorized to sign on behalf of the Bidder. All pages of the Bid shall be signed by the person or persons signing the Bid.

18.3. The Bid shall contain no overwriting alternations or additions, except those to comply with instruction issued by the Employer or as necessary to correct errors made by the Bidder, in which case such corrections shall be made by scoring out the cancelled portion, writing the correction and initialing and dating it by the person or persons signing the Bid.

D. Submission of Bids

Online submission as per Govt. of Odisha e-Procurement Procedure annexed

19. Sealing and Marking of Bids – Refer e-procurement procedure as annexed in Annexure-I to ITB for cover-I and cover-II of the bid (clause-12.1).

19.1. The bid documents as per cover-III of clause-12.1 shall be submitted in sealed cover (in off line).

Technical Bid : To be opened on dt.31.12.2024 at 11:30 AM.

Financial Bid : Not to be opened except with approval of the Employer. The contents of the "Technical Bid" and "Financial Bid" shall be as specified in clause-12.1 of ITB.

19.2. The sealed envelope (cover-III) as per clause-12.1 shall be -

- a) be addressed to the Employer at the address provided in the clause-1.1 of the ITB.
- b) bear the name and identification number provided in clause-1 of IFB.
- c) provide a warning not to be opened before the specified time and date for opening as mentioned in clause-23.1 of ITB.

19.3. In addition to the identification required in clause-19.2, each of the envelopes shall indicate the name and address of Bidder to enable the Bid to be returned unopened in case it is declared late pursuant to clause-20.1 of ITB or declared non-responsive, pursuant to clause -27 of the ITB.

20. Deadline for Submission of the Bids

20.1 Bid shall be received on or before **Dt.30.12.2024** at 5:00 PM as notified in IFB.

20.2 The Employer may extend the deadline for submission of bids by issuing an amendment in accordance with Clause 10, in which case all rights and obligations of the Employer and the bidders previously subject to the original deadline will then be subject to the new deadline.

21. Late Bids:

Any Bid received by the Employer after the dead line prescribed in clause-20 of ITB will be returned unopened to the Bidder.

E. BID OPENING AND EVALUATION

22. Bid Opening:

22.1 All the bids received shall be opened in the Office of Divisional Forest Officer, Puri Wildlife Division, Puri on **dt.31.12.2024** at 11:30 AM in the presence of the Bidders or their representatives who choose to attend. In the event of the specified date of Bid opening being declared a holiday, the Bids will be opened at the appointed time and location on the next working day.

22.2 The Employer shall prepare minutes of the Bid opening.

23. Process to be Confidential:

Information relating to the examination, clarification, evaluation, and comparison of Bids and recommendations for the award of a contract shall not be disclosed to Bidders or any other persons not officially concerned with such process until the award is successful and Bidder has been announced. Any effort by a Bidder to influence the Employer's processing of Bids or award decisions may result in the rejection of his Bid.

24. Clarification of Financial Bids:

24.1. To assist in the examination, evaluation, and comparison of Bids, the Employer may, at his discretion, ask the lowest evaluated responsive bidder for clarification of his-Bid, including breakdowns of unit rates. The request for clarification and the response shall be in writing or by cable/e-mail, but no change in the price or substance of the Bid shall be sought, offered, or permitted.

24.2. Subject to sub-clause 24.1, no Bidder shall contact the Employer on any matter relating to his bid from the time of the bid opening to the time the contract is awarded. If the Bidder wishes to bring additional information to the notice of the Employer, it should do so writing.

24.3. Any effort by the Bidder to influence the Employer in the Employer's bid evaluation, bid comparison or contract award decisions may result in the rejection of the Bidders' bid.

25. Examination of Bids and Determination of Responsiveness:

During the detailed evaluation of "Technical Bids", the Employer will determine whether each Bid

- (a) Meets the eligibility criteria defined in Clause 3 and 4;
- (b) Is accompanied by the required securities and;
- (c) Is substantially responsive to the requirements of the Bidding documents.

26. Evaluations and Comparison of Financial Bids

- 26.1.** The Employer will evaluate and compare only the Bids determined to be substantially responsive in accordance with the procedure as per **Annexure-II**.
- 26.2.** The Employer reserves the right to accept or reject any variation arising out of change in scope of work. Such variations, which are in excess of the requirements of the Bidding documents, shall not be taken into account in Bid evaluation.

E. AWARD OF CONTRACT

27. Award Criteria:

- 27.1** Subject to Clause 28, the Employer will award the Contract to the Bidder whose Bid has been determined to be substantially responsive to the Bidding documents and who has been selected in compliance to clause-26.1, provided that such Bidder has been determined to be (a) eligible in accordance with the provisions of Clause 3 and (b) qualified in accordance with the provisions of Clause 4.
- 27.2** In no case, the contract shall be awarded to any bidder whose available bid capacity is less than the evaluated bid price, even if the said bid is the lowest evaluated bid. The contract will in such cases be awarded to the next lowest bidder at his evaluated bid price.

28. Employer's Right to accept any Bid and to reject any or all Bids:

- 28.1** Notwithstanding Clause 27, the Employer reserves the right to accept or reject any Bid and to cancel the Bidding process and reject all Bids at any time prior to the award of Contract, without thereby incurring any liability to the affected Bidder or Bidders or any obligation to inform the affected Bidder or Bidders of the grounds for the Employer's action.

29. Notification of Award and Signing of Agreement:

- 29.1** The Bidder whose Bid has been accepted will be notified of the award by the Employer prior to expiration of the Bid validity period by cable, telex, facsimile or e-mail confirmed by registered letter. This letter (hereinafter and in the Conditions of Contract called the "Letter of Acceptance") will state the sum that the Employer will pay the Bidder in consideration of the design and execution the Works on a turnkey basis by the Bidder as prescribed by the Contract (hereinafter and by the Contract called the "Contract Price").
- 29.2** The notification of award will constitute the formation of the Contract, subject to condition that after furnishing of a performance security in accordance with the provisions of Clause 30 the award will be complete.
- 29.3** The Contract will incorporate all agreements between the Employer and the successful Bidder. The detail work programme and milestone wise activity shall be finalized during contract negotiation with the successful bidder within 14 days after notification of award. The agreed work programme / milestone shall form part of the contract agreement. The agreement will be signed by the Employer and sent to the successful Bidder, within 28 days following the notification of award along with the Letter of Acceptance. Within 21 days of receipt, the successful Bidder will sign the Agreement and deliver it to the Employer.
- 29.4** Upon the furnishing by the successful Bidder of the Performance Security, the Employer will promptly notify the other Bidders that their Bids have been unsuccessful.
- 29.5** In the event of non-payment of the performance security by the L1 bidder, the successful bidders in sequence (L2, L3) may be asked for negotiation for execution of the work with the bid price quoted by the L1 bidder.

30 Performance Security:

30.1 Within 10 days of receipt of the Letter of Acceptance, the successful Bidder shall deliver to the Employer a Performance Security [valid for a period as stipulated in Cl. 48 of Conditions of Contract & in the contract data] in any of the forms given below for an amount equivalent to 5% of the Contract price:

- a bank guarantee in the form given in Section 6; or

- a deposit receipt of Schedule Bank / Post Office Savings Bank Account / National Savings Certificate / Postal Office Time Deposit Account duly pledged in favour of the Divisional Forest Officer, Puri Wildlife Division, Puri payable at Puri. The bidder has the option of furnishing Bid Security in the form of Bank Guarantee from a Nationalized Bank of India, counter guaranteed by its branch at Puri.

30.2 If the performance security is provided by the successful Bidder in the form of a Bank Guarantee, it shall be issued either (a) at the Bidder's option, by a Nationalized/ Scheduled Indian bank or (b) by a foreign bank located in State and acceptable to the Employer.

30.3 Failure of the successful Bidder to comply with the requirements of Sub-Clause 30.1 and/or 30.2 shall constitute sufficient grounds for cancellation of the award and forfeiture of the Bid Security.

31. Advance Payment and Security - The Employer shall make advance payment to the Contractor of the amounts stated in the Contract Data by the date stated in the Contract Data, against provision by the Contractor of an Unconditional Bank Guarantee in a form and by a Bank acceptable to the Employer in amounts and currencies equal to the advance payment.

32. Corrupt or Fraudulent Practices:

32.1 It is required that the bidders / contractors observe the highest standard of ethics during the procurement and execution of such contracts. In pursuance of this policy, it is:

(a) Defined, for the purposes of this provision, the terms set forth below as follows:

(i) "Corrupt practice" means the offering, giving, receiving or soliciting of anything of value to influence the action of a public official in the procurement process or in contract execution and

(ii) "Fraudulent practice" means a misrepresentation of facts in order to influence a procurement process or the execution of a contract to the detriment of the Employer and includes collusive practice among Bidders (prior to or after bid submission) designed to establish bid prices at artificial non-competitive levels and to deprive the Government of the benefits of free and open competition.

The Employer will reject a proposal for award if it determines that the Bidder recommended for award has engaged in corrupt or fraudulent practices in competing for the contract in question and will declare the firm ineligible, either indefinitely or for a stated period of time, to be awarded a contract, if it at any time determines that the firm has engaged in corrupt or fraudulent practices in competing for, or in executing the contract.

32.2 Furthermore, Bidders shall be aware of the provision stated in sub-clause 23.2 and sub-clause 54.2 of the Conditions of Contract.

ANNEXURE-I

Procedure to participate in online bidding- e-procurement (Refer clause-19 of ITB)

1. **PARTICIPATING IN THE BID IN THE E-PROCUREMENT PORTAL:** The Contractor/Bidder intending to participate in the bid is required to register in the Portal with some information about the firm/Contractor. This is a onetime activity for registering in Portal. During registration, the contractor has to attach a Digital Signature Certificate (DSC) to his / her unique user ID. The DSC used must be of appropriate class (Class II or Class III) issued from a registered Certifying Authority such as n-Code, Sify, TCS, MTNL etc. and:
 - (a) To log on to the portal the Contractor/Bidder is required to type his/her username and password. The system will again ask to select the DSC and confirm it with the password of DSC. For each login, a user's DSC will be validated against its date of validity and also against the Certificate Revocation List (CRL) of respective CAs stored in system database. The system checks the unique ID, password and DSC combination and authenticates the login process for use of portal.
 - (b) The tender documents uploaded by the Tender Inviting Officer in the website www.tendersodisha.gov.in will appear in the section of "Upcoming Tender" before the due date of tender sale. Once the due date has arrived, the tender will move to "Active Tender" Section of the homepage. Only a small notification will be published in the newspaper specifying the work details along with mention of the specific website for details. The publication of the tender will be for specific period of time till the last date of submission of bids as mentioned in the 'Invitation for Bid' after which the same will be removed from the list of Active tenders. Any bidder can view or download the bid documents from the web site.
 - (c) Contractor exempted from payment of EMD will be able to participate in the tender directly by uploading documentary evidences towards his eligibility for such exemption.
 - (d) If the software application has the provision of payment of cost of tender document through payment gateways of authorized bankers by directly debiting the account of the bidders, bidders will be required to avail on-line payment.
- 1.1. Furnishing scanned copy of such documents is mandatory along with the tender documents otherwise his/her bid shall be declared as non-responsive and thus liable for rejection.
- 1.2. In the case of any failure, malfunction, or breakdown of the electronic system used during the e-procurement process, the tender inviting officer shall not accept any responsibility for failures or breakdowns other than in those systems strictly within their own control.
- 1.3. Any third party/company/person under a service contract for operation of e-procurement system in the State or his/their subsidiaries or their parent companies shall be ineligible to participate in the procurement processes that are undertaken through the e-procurement system irrespective of who operates the system.
- 1.4. For submission of Bids through the E-Procurement Portal, the bidder shall upload the scanned copy/copies of document in prescribed format wherever warranted in support of eligibility criteria and qualification information. The on-line bidder shall have to produce the original documents in support of the scanned copies and statements uploaded in the portal before the specified date as per DTCN.
- 1.5. Each bidder shall submit only one bid for one package. A bid is said to be complete if accompanied by cost of bid document and appropriate bid security. The system shall consider only the last bid

submitted through the E-Procurement portal.

- 1.6. The **Officer inviting the bid / Engineer-in-Charge** will clarify queries on the Contract Data on requisition by the intending Bidder. The bidder may ask question in the e-procurement portal using his DSC; provided the questions are raised before the date mentioned in the home page under critical dates.
- 1.7. The bids uploaded by the Tender Inviting Officer may consist of general arrangements drawings or typical sections of the project. Bidder may download these drawings and take out the print for detail study. Any other drawings and documents pertaining to the works available with the officer inviting the Bid as well as in the office of the Superintending Engineer and Executive Engineer as mentioned in the Contract Data will be open for inspection by the bidders. The bidder is required to download all the documents including the drawings for preparation of his bid. It is not necessary for the part of the Bidder to upload the drawings other Bid documents (after signing) while uploading his bid. He is required to upload documents related to his eligibility criteria and qualification information and Bill of Quantities duly filled in. It is assumed that while participating in the bid, the bidder has referred all the drawings and documents uploaded by the Officer Inviting the Bid. Seeking any revision of rates or backing out of the bid claiming for not having referred to any or all documents provided in the Bid by the Officer Inviting the Bid will be construed as plea to disrupt the bidding process and in such cases the bid security shall be forfeited.
- 1.8. Any addendum issued shall be part of the bidding documents and shall be notified in the website www.tendersodisha.gov.in/ notice board and through paper publication.
 - 1.8.1. All the volumes/documents shall be provided in the portal by the Officer inviting the bid. The bidder shall carefully go through the document and prepare the required documents and upload the scanned documents in Portable Document Format to the portal in the designated locations of Technical Bid. He will fill up the rates of items or percentage in the BOQ downloaded for the work in designated Cell and uploads the same in designated locations of Financial Bid. Submission of document shall be affected by using DSC of appropriate class.
- 2. BID SECURITY:** The Bidder shall furnish, as part of his Bid, a Bid security for the amount mentioned under NIT/Contract Data. The bidder shall scan all the written pages of the bid security and upload the same to the system in designated place. The on-line bidder shall deposit the original copy of the 'bid security' within the specified period mentioned in the DTCN (after receipt date of bid but before opening date & time of bid) with the "Officer inviting the Bid". The Officer inviting the bid shall not be responsible for any postal delay and/or non-receipt of the original copy of the bid security on or before specified date and time. Non-submission of bid security within the designated period shall debar the bidder from participating in the on-line bidding system and his portal registration shall be cancelled. His name shall also be informed to the registering authority for cancellation of his registration.
- 3. FORMAT AND SIGNING OF BID:** The bidder can download the tender of his choice and save it in his system and undertake the necessary preparatory work off-line and upload the completed tender at his convenience within the final date and time of submission. The bidder shall only submit single copy of the required documents and Price Bid in the portal. In the Financial bid, the bidder cannot leave any figure blank. He has to only write the figures; the words will be self-generated. The Bidders are advised to upload the completed Bid document well ahead of the last date & time of receipt to avoid any last moment problem of power failures etc.
 - 3.1.** The Bidder shall go through the Bid carefully and list the documents those are asked for submission. He shall prepare all documents including cost of Bid Document, Bid Security, Declaration form, price bid etc. and store in the system.

3.2. The bidder shall log on to the portal with his DSC and move to the desired tender for up loading the documents in appropriate place one by one simultaneously checking the documents. Once the Bidder makes sure that all the documents have been up-loaded in appropriate place, he clicks the submit button to submit the bid to the portal.

3.2.1. The bids once submitted cannot be retrieved or corrected. Tender cannot be pre-opened and cannot be submitted after due date and time. Therefore, only after satisfying that all the documents have been uploaded, the Bidder should activate submit button.

3.2.2. In the e-procurement process each process are time stamped. The system can identify each individual who has entered in to the portal for any bid and the time of entering in to the portal.

3.2.3. The Bidder should ensure clarity of the document up loaded by him to the portal especially the scanned documents by taking out sample printing. Non-submission of legible documents may render the bid non-responsive. However, the Officer inviting the Bid if so desires can ask for legible copies or original copies for verification with in a stipulated period provided such document in no way alters the Bidder's price bid. If the Bidder fails to submit the original documents with in the stipulated date, his bid security shall be forfeited.

4. SECURITY OF BID SUBMISSION:

4.1. All bid data uploaded by the Bidder to the portal will be encrypted by the DSC. The system shall require all the mandatory forms and fields filled up by the contractor during the process of submission of the bid/tender.

4.2. The Bid shall be received in encrypted format by the system which can only be decrypted / opened by the authorized openers only on or after the due date and time.

5. DEADLINE FOR SUBMISSION OF THE BIDS:

The online bidding will remain active till the last date and time of the bid submission. Once the date and time (Server date and time) is over, the bidder will not be able to submit the bid. The date & time of bid submission shall remain unaltered even if the specified date for the submission of bids declared as a holiday for the Officer inviting the Bid.

6. LATE BIDS:

The system shall reject submission of any bid through portal after closure of the receipt time. For all purpose the server time displayed in the e-procurement portal shall be the time to be followed by the bidder and concerned officers.

7. MODIFICATION AND WITHDRAWAL OF BIDS:

7.1. In the E-Procurement Portal, it is allowed to modify the bid any number of times before the final date and time of submission. The bidder shall have to log on to the system and resubmit the documents as asked for by the system including the price bid. In doing so, the bids already submitted by the bidder will be removed automatically from the system and the latest bid only will be admitted. But the bidder should avoid modification of bid at the last moment to avoid system failure or malfunction of internet or traffic jam or power failure. If the bidder fails to submit his modified bids with in the designated time of receipt, the bid already in the system shall be taken for evaluation.

7.2. In the E-Procurement Portal, withdrawal of bid is allowed. But in such case, he has to write a letter with appropriate reasons for his with drawl addressed to the Officer inviting the bid and up load the scanned document to portal in the respective bid before the closure date and time of receipt of the bid. The system shall not allow any withdrawal after expiry of the closure time of the bid.

8. OPENING OF THE BID:

8.1. Bid opening date is specified during tender creation or can be extended with corrigendum. This date is available in IFB, tender document as well as the home page of portal. Bid opening can be done by the authorized users which are defined during the tender publication / approval stage. The bids are

encrypted using their public keys and can be decrypted only on or after the Bid Opening due date and time. The bid openers private key will be required to open the bids and all the openers have to log on to the portal during that time.

- 8.1.1. The bidders who participated in the on-line bidding can witness opening of the bid from any system logging on to the portal with the DSC away from opening place. Contractors are not required to be present during the bid opening at the opening location if they so desire.
- 8.1.2. Each activity is date and time stamped with **user** details. For time stamping, server time is taken as the reference.
- 8.2. In the event of the specified date of bid opening being declared a holiday for the Officer inviting the Bid/Engineer-in-Charge, the bids will be opened at the appointed time on the next working day.
- 8.3. In case bids are invited for more than one package, the order for opening of the "Bid" shall be that in which they appear in the "Invitation for Bid".
- 8.4. During bid opening, the covers containing original financial instruments towards Cost of bid and Bid Security in the form specified in the DTCN, received after last date of receipt of bid and before opening of the bids shall be opened and declared.
 - 8.4.1. Combined bid security for more than one work is not acceptable.
- 8.5. The Bid openers; who have been pre-defined shall log on to the portal with their respective DSC. Unless all the Officers who have been declared as Opening officers, log on the portal with their DSC the Tender cannot be opened.
 - 8.5.1. The Opening Officers will systematically check the scanned demand draft towards cost of the bid document and the scanned document of Bid security with that of the original submitted. If found in order, they will continue opening of all other documents in the system provided under Technical Bid.
 - 8.5.2. Subject to confirmation of the bid security by the issuing institutions, the bids accompanied with appropriate bid cost and valid bid security will be taken up for evaluation with respect to the qualification Information and other information furnished.
 - 8.5.3. After receipt of confirmation of the bid security, the bidder may be asked in writing to clarify to the documents in the Technical Bid, if necessary, with respect to any doubts or illegible documents required for Technical Evaluation.
 - 8.5.4. The bidders will respond in not more than 7 days of issue of the clarification letter, failing which the bid of the bidder will be evaluated on its own merit
 - 8.5.5. Immediately, on receipt of these clarifications, the Evaluating Officers; predefined in the system for the bid, will finalize the list of responsive bidders. They will log on to the site with their DSC and record their comments on the Technical evaluation page in the system. The Officer Inviting the Bid if also the accepting authority, shall log on to the system with his digital signature and check the technical evaluation. He can either accept or pass on to the evaluating officers for re-evaluation. Upon acceptance of technical evaluation by the Accepting authority in the system, the system shall automatically generate letter to all the responsive bidders and the system shall forward the letter to all the responsive bidder that their technical bid has been evaluated responsive with respect to the data/information furnished by him and the letter shall also intimate him the date & time of opening of financial bid. The system shall also inform the non-responsive bidders in their e-mail ID that their bid has been found non-responsive.
- 8.6. The Technical evaluation of all the bids will be taken up as per the information furnished by the Bidders. But evaluation of the bid does not exonerate the bidders from checking their original documents and if at a later date the bidder is found to have misled the evaluation through wrong information, action as per relevant clause of DTCN shall be taken against the bidder/contractor.
- 8.7. After **technical** evaluation of the bidders and selection of the qualified bidders, the financial bids of the technically qualified bidders shall be opened on the due date of opening. Members of the bid

opening committee log on to the system in sequence and open the financial bids for the technically qualified bidders. The opening of financial bid by the opening officer using their DSC shall decrypt the financial bids in the following manner:

- 8.7.1. Opening of price bid and evaluation of lowest bidder is subject to satisfaction of other qualification information.
- 8.7.2. The Financial Bid will be opened on the notified date & time in the presence of bidders or their authorised representative who wish to be present.
- 8.7.3. At the time of opening of "Financial Bid", the names of the bidders whose technical bids were found responsive will be announced and the bids of only those bidders will be opened. The remaining bids will be rejected.
- 8.7.4. The responsive bidders' name, the bid prices, the item wise rates the total amount of each item, any discounts and withdrawals, and such other details as the officer inviting the tender may consider appropriate, will be announced by him or his authorized representatives at the time of opening.
- 8.7.5. Rebate/discount offer if any uploaded to the system shall be declared and recorded first.
- 8.7.6. The Financial bid of the bidders shall be opened one by one by the designated officers. The system shall auto-generate the Comparative statement.
- 8.7.7. The Bidder can witness the principal activities and view the documents/summary reports for that particular work by logging on to the portal with his DSC from anywhere.

9. CLARIFICATION OF BIDS:

- 9.1. For examination, evaluation, and comparison of bids, the officer inviting the bid may, at his discretion, ask lowest bidder for clarification of his rates including reduction of rate on negotiation and breakdowns of unit rates.
- 9.2. On opening of the price bid the system shall arrange the financial bids in order of their value (L1 first, followed by L2, L3) for subsequent evaluation. The evaluation status (Sheet) will be visible to all the participating bidders after opening on their respective logins. Each activity is recorded in the system with date and time stamping.

10. NOTIFICATION OF AWARD AND SIGNING OF AGREEMENT:

In the E-Procurement Portal, the system shall generate the template of award letter and the Officer Inviting the Bid shall mention the amount of Performance Security and additional security required to be furnished in the letter and intimate the bidders in his e-mail ID. The issue of the letter of acceptance shall be treated as closure of the Bid process and commencement of the contract.

ANNEXURE-II

EVALUATION CRITERIA (Clause-26.1 of ITB)

1.1 INTRODUCTION

Evaluation Criteria contains the broad criteria based on which the applicants shall be evaluated.

1.2 EVALUATION CRITERIA

Applicants Technical Bid will be evaluated based on their financial standing, technical and organizational capability and past experience and track record. The Applicants are required to submit all the necessary details including certificates from the client agencies in support of their application.

CRITERIA FOR EVALUATION OF THE PERFORMANCE OF CONTRACTORS FOR PRE-ELIGIBILITY

| Sl. No | Attributes | Marks | Evaluation |
|------------|--|--|--|
| (a) | Financial strength (i) Average annual Turnover (ii) Solvency Certificate as per clause-4.4 A. iv of ITB | (25 marks) 21 marks 4 marks | 60% marks for minimum eligibility criteria. 100% marks for twice the minimum eligibility criteria or more in between (i) & (ii) – on pro-rata basis. |
| (b) | Experience in building project works | (25 marks) | 60% marks for minimum eligibility criteria 100% marks for twice the minimum eligibility criteria or more in between (i) & (ii) – on pro-rata basis. |
| (c) | Personnel and Establishment | (25 Marks) | 60% marks for minimum eligible criteria. |
| | (i) Graduate Engineer (civil) with 15 years' experience | 1 mark for each max 4 marks | |
| | (ii) Graduate Engineer (civil) with 10 years' experience | .75 marks for each max 4 marks | |
| | (iii) Graduate Engineer (civil) with 5 years' experience | .50 marks for each max 2 marks | |
| | (iv) Diploma Engineer (civil) with 10 years' experience | .25 marks for each max 1 mark | |
| | (v) Architect with 10 years' experience | 1 mark for each max 4 marks | |
| | (vi) Architect with 5 years' experience | .50 marks for each max 2 marks | |
| | (vii) Graduate Engineer (electrical) with 10 years' experience | .50 marks for each max 4 marks | |
| | (viii) Graduate Engineer (mechanical) with 10 years' experience | .50 marks for each max 4 marks | |
| (d) | Plant & Equipment | (25 Marks) | |
| 1. | Cement Concrete batch mix plant | Maximum 6 marks | |
| 2. | Vibrator / Equipment | Maximum .5 marks | |
| 3. | Excavator | Maximum .5 marks | |
| 4. | Complete steel staging and | Maximum 4 marks | |

| | | |
|-----|---|------------------|
| | shuttering materials. | |
| 5. | Field Testing equipment | Maximum 2 marks |
| 6. | Truck & Tipper | Maximum .5 marks |
| 7. | Modern sophisticated theodolite with leveling machine | Maximum .5 marks |
| 8. | Hoisting crane upto height | Maximum 4 marks |
| 9. | Truck mounted transit mixture with concrete pump | Maximum 3 marks |
| 10. | Pile driving machine | Maximum 2 marks |
| 11. | Construction Elevator | Maximum 2 marks |

The bidders qualifying the initial criteria as set out will be evaluated for following criteria by scoring method on the basis of details furnished by them.

| S. No. | Criteria | Maximum Marks | Minimum to be scored |
|---------------|--|----------------------|-----------------------------|
| a | Financial Strength | 25 | 15 |
| b | Experience in Similar Nature of work during last 5 years | 25 | 15 |
| c | Personnel and Establishment | 25 | 15 |
| d | Plant & Equipment | 25 | |
| | Total Marks | 100 | 70 |

2.1 The bidders who qualify as per Clause 1 above securing 70 marks out of 100 only will be asked to apprise before a High-Level Committee (to be notified) about their work programme modalities of execution along with conceptual drawings and specification of finishing items of the proposed buildings on the schedule date and time (to be intimated to the qualified bidders as per clause 1 above only by post / E-mail / FAX).

2.2 The Technical presentation as per clause 2.1 shall be done before a committee headed by Divisional Forest Officer, Puri Wildlife Division of the client department. The presentation will be awarded marks out of 100 (hundred). The bidders securing 70% and above marks will be qualified.

The results of technical presentation would be conveyed to the participated bidders.

2.3 The financial bid (in cover-II) will only be opened after completion of stage (as per clause 2.2) and evaluated as under.

The proposal with the lowest financial bid will be awarded the work.

2.4 The Evaluation of the bid will be based on clause 2.2 and 2.3 taken together.

SECTION 2

FORMS OF BID, QUALIFICATION INFORMATION AND LETTER OF ACCEPTANCE

TABLE OF FORMS:

- **CONTRACTOR'S BID**
- **QUALIFICATION INFORMATION**
- **LETTER OF ACCEPTANCE**
- **NOTICE TO PROCEED WITH THE WORK**
- **AGREEMENT FORM**

Contractor's Bid

DESCRIPTION OF THE WORKS: BID FOR DESIGN AND EXECUTION ON TURN KEY BASIS FOR CONSTRUCTION OF [INSERT NAME OF BUILDING INCLUDING LOCATION OF PROPOSED BUILDING]

BID

To: [Insert name of bid inviting authority who shall receive bid on behalf of the Employer]

Address: [inset office address]

GENTLEMEN,

Having examined the bidding documents including addendum, I / we offer to execute the Works described above in accordance with the conditions of contract, specifications, accepted tendered drawing, and Payment schedule accompanying this Bid for the Contract Price as tendered in our price bid document separately

The advance Payment required is: Rupees _____

This Bid and your written acceptance of it shall constitute a binding contract between us. We understand that you are not bound to accept the lowest or any Bid you receive.

We undertake that, in competing for (and if the award is made to us, in executing) the above contract, we will strictly observe the laws against fraud and corruption in force in India namely "Prevention of Corruption Act 1988".

We hereby confirm that this Bid complies with the Bid Validity and Bid Security required by the Bidding documents.

We attach herewith our current income-tax clearance certificate.

Yours faithfully,

Authorized Signature:

Name & Title of Signatory: _____

Name of Bidder : _____

Address : _____

Qualification Information

The information to be filled in by the Bidder in the following pages will be used for purposes of post qualification as provided for in Clause 4 of the Instructions to Bidders. This information will not be incorporated in the Contract.

1. For Individual Bidders

1.1 Constitution or legal status of Bidder

[Attach copy]

Place of registration: _____

Principal place of business: _____

Power of attorney of signatory of Bid

[Attach]

1.2 Financial Turnover of the bidder during the last five financial years duly certified by the registered chartered accountant. (in Rs. **Crores**)

1.3.1 Work performed as prime contractor (in the same name) on building project works over the last seven financial years. **

| Project Name | Name of the Employer* | Description of work | Contract No. | Value of contract (Rs.Lakhs) | Date of issue of work order | Stipulated period of completion | Actual date of completion* | Remarks explaining reasons for delay and work completed |
|--------------|-----------------------|---------------------|--------------|-------------------------------|-----------------------------|---------------------------------|----------------------------|---|
| (1) | (2) | (3) | (4) | (5) | (6) | (7) | (8) | (9) |

*Attach certificate (s) from the Engineer(s)-in-Charge

@The item of work for which data is requested should tally with that specified in ITB clause 4.4A.

** Immediately preceding the financial year in which bids are received.

1.4 Information on Bid Capacity (works for which bids have been submitted and works which are yet to be completed) as on the date of this bid.

(A) Existing commitments and on-going works:

| Description of Work | Place & State | Contract No. & Date | Name and Address of Employer | Value of Contract (Rs. Lakhs) | Stipulated period of completion | Value of works* remaining to be completed (Rs. Lakhs) | Anticipated date of completion |
|---------------------|---------------|---------------------|------------------------------|-------------------------------|---------------------------------|---|--------------------------------|
| (1) | (2) | (3) | (4) | (5) | (6) | (7) | (8) |

(B) Works for which bids already submitted:

| Description of Work | Place & State | Name and Address of Employer | Estimated value of works (Rs. In lakhs) | Stipulated period of completion | Date when decision is expected. | Remarks if any |
|---------------------|---------------|------------------------------|---|---------------------------------|---------------------------------|----------------|
| (1) | (2) | (3) | (4) | (5) | (6) | (7) |

* Attach certificate(s) from the Engineer(s)-in-Charge.

1.5 The following items of Contractor's Equipment are essential for carrying out the Works. The Bidder should list all the information requested below. Refer also to Sub Clause 4.2(d) read with 4.4 (B) of the Instructions to Bidders.

| Item of Equipment | Requirement | Availability Proposals | | Age/Condition | Remarks (From whom to be purchased) |
|-------------------|-------------|------------------------|------------------------------|---------------|-------------------------------------|
| | No. | Nos./Capacity | Owned/Leased/ to be procured | | |

1.6 Qualifications and experience of key personnel proposed for administration and execution of the Contract. Attach biographical data. Refer also to 4.2(e) read with annexure of instructions to Bidders and Sub Clause 9.1 of the Conditions of Contract.

| Position | Name | Qualifications | Years of experience (general) | Years of experience in the proposed position |
|----------|-------------------------|----------------|-------------------------------|--|
| | Project Manager etc. | | | |

1.7 Proposed subcontracts and firms involved. [Refer ITB Clause 4.2 (j)]

| Sections of the works | Value of Sub-contract | Sub-contractor (name and address) | Experience in similar work |
|-----------------------|-----------------------|-----------------------------------|----------------------------|
|-----------------------|-----------------------|-----------------------------------|----------------------------|

1.8 Financial reports for the last five financial years: balance sheets, profit and loss statements, auditors' reports (in case of companies/corporation), etc. List them below and attach copies.

1.9 Evidence of access to financial resources to meet the qualification requirements: cash in hand, lines of credit, etc. List them below and attach copies of support documents [sample format attached].

1.10. Name, address, and telephone, telex, and fax numbers of the Bidders' Bankers who may provide references if contacted by the Employer.

1.11 Information on litigation history in which the Bidder is involved.

| Other party(ies) | Employer | Cause of dispute | Amount involved | Remarks showing Present status |
|------------------|----------|------------------|-----------------|--------------------------------|
|------------------|----------|------------------|-----------------|--------------------------------|

1.12 Statement of compliance under the requirements of Sub Clause 3.2 of the instructions to Bidders.

1.13 Proposed work method and schedule. The Bidder should attach descriptions, drawings and charts as necessary to comply with the requirements of the Bidding documents. [Refer ITB Clause 4.1 and 4.2 (k)].

**SAMPLE FORMAT FOR EVIDENCE OF ACCESS TO OR AVAILABILITY OF CREDIT
FACILITIES – CLAUSE 4.4 [B] [C] OF ITB**

BANK CERTIFICATE

This is to certify that M/s. is a reputed company with a good financial standing.

If the contract for the work, namely “[insert name of the work]” on turn key basis involving design and execution of works is awarded to the above firm, we shall be able to provide overdraft/credit facilities to the extent of Rs. to meet their working capital requirements for executing the above contract.

Name of Bank
Senior Bank Manager
Address of the Bank

AFFIDAVIT

- 1 I, the undersigned, do hereby certify that all the statements made in the required attachments are true and correct.

- 2 The undersigned also hereby certifies that neither our firm M/s.....
..... have abandoned any work on building in India nor any contract awarded to us by the State of Odisha for such works have been rescinded, during last five years prior to the date of this bid.

- 3 The undersigned hereby authorize(s) and request(s) any bank, person, firm or corporation to furnish pertinent information deemed necessary and requested by the Department to verify this statement or regarding my (our) competence and general reputation.

- 4 The undersigned understand and agrees that further qualifying information may be requested, and agrees to furnish any such information at the request of the Department/ Project implementing agency.

(Signed by an Authorized Officer of the Firm)

Title of Officer :

Name of Firm :

DATE :

Letter of Acceptance
(letterhead paper of the Employer)

_____ [date]

To: _____ [name and address of the Contractor]

Dear Sir(s)

This is to notify you that your Bid dated _____ for execution of the work "**[insert name of the work]**" on turn key basis involving design and execution of works _____ [Name of the contract and identification number, as given in the Instructions to Bidders] for the Contract Price of Rupees _____ (_____) [amount in words and figures], as corrected and modified in accordance with the Instructions to Bidders¹ is hereby accepted by our Agency.

We note that as per bid, you do not intend to subcontract any component of work

(Or)

We note that as per bid, you propose to employ _____ as sub-contractor for executing _____

(Delete whichever is not applicable)

You are hereby requested to furnish Performance Security and Additional Performance Security (if any) in the form detailed in Para 30.1 of ITB for an amount of Rs..... within **15** days of the receipt of this letter of acceptance and sign the contract failing which action as stated in Para 30.3 of ITB will be taken.

Yours faithfully,

Authorized Signature

Name and Title of Signatory

Name of Agency

¹ Delete "corrected and" or "and modified" if only one of these actions applies. Delete "as corrected and modified in accordance with the Instructions to Bidders" if corrections or modifications have not been effected.

Issue of Notice to proceed with the work

(letterhead of the Employer)

_____ (date)

To

_____ (name and address of the Contractor)

Dear Sirs:

Pursuant to your furnishing the requisite security as stipulated in ITB clause 30.1 and signing of the contract agreement for the work "[insert name of the work]" on turn key basis involving design and execution of works @ a Bid Price of Rs. _____, you are hereby instructed to proceed with the execution of the said works in accordance with the contract documents.

Yours faithfully,

(Signature, name and title of
signatory authorized to sign on
behalf of Employer)

Agreement Form

Agreement

This agreement, made the _____ day of _____ 20...., between

_____ [name and address of Employer]

(hereinafter called "the Employer)" of the one part and _____

_____ [name and address of contractor] (hereinafter called "the Contractor") of the other part.

Whereas the Employer is desirous that the Contractor "[insert name of the work], [name and identification number of Contract] (hereinafter called "the Works") and the Employer has accepted the Bid by the Contractor for the execution and completion of such Works and the remedying of any defects therein, at a contract price of Rs.....

NOW THIS AGREEMENT WITNESSETH as follows:

1. In this Agreement, words and expression shall have the same meanings as are respectively assigned to them in the Conditions of Contract hereinafter referred to, and they shall be deemed to form and be read and construed as part of this Agreement.
2. In consideration of the payments to be made by the Employer to the Contractor as hereinafter mentioned, the Contractor hereby covenants with the Employer to execute and complete the Works and remedy any defects therein in conformity in all aspects with the provisions of the Contract.
3. The Employer hereby covenants to pay the Contractor in consideration of the execution and completion of the Works and the remedying the defects wherein the Contract Price or such other sum as may become payable under the provisions of the Contract at the times and in the manner prescribed by the Contract.
4. The following documents shall be deemed to form and be read and construed as part of this Agreement, viz.:
 - i) Letter of Acceptance
 - ii) Notice to proceed with the works
 - iii) Contractor's Bid
 - iv) Contract Data
 - v) Conditions of contract (including Special Conditions of Contract)
 - vi) Specifications
 - vii) Drawings
 - viii) Bill of Quantities (Optional)
 - ix) Payment Schedule and
 - x) Any other document listed in the Contract Data as forming part of the contract.

In witness whereof the parties thereto have caused this Agreement to be executed the day and year first before written.

The Common Seal of _____

was hereunto affixed in the presence of:

Signed, Sealed and Delivered by the said _____

in the presence of:

Binding Signature of Employer _____

Binding Signature of Contractor _____

**SECTION 3:
CONDITIONS OF CONTRACT**

Conditions of Contract

Table of Contents

A. General

1. Definitions
2. Interpretation
3. Language and Law
4. Engineer's Decisions
5. Delegation
6. Communications
7. Subcontracting
8. Other Contractors
9. Personnel
10. Employer's & Contractor's Risks
11. Employer's Risks
12. Contractor's Risks
13. Insurance
14. Site Investigation Reports
15. Queries about the Contract Data
16. Contractor to Construct the works
17. The Works to Be Completed by the Intended Completion Date
18. Approval by the Engineer the Intended Completion Date
19. Safety
20. Discoveries
21. Possession of the Site
22. Access to the Site
23. Instructions
24. Disputes
25. Procedure for Disputes
26. Replacement of Adjudicator

B. Time Control

27. Program
28. Extension of the Intended Completion Date
29. Delays Ordered by the Engineer
30. Management Meetings
31. Early Warning

C. Quality Control

32. Identifying Defects
33. Tests
34. Correction of Defects
35. Uncorrected Defects

D. Cost Control

36. Changes in the Quantities
37. Variations
38. Payments for Variations
39. Payment Certificates
40. Payments
41. Compensation Events
42. Tax
43. Currencies
44. Retention
45. Liquidated Damages
46. Bonus
47. Advance Payment
48. Securities
49. Cost of Repairs

E. Finishing the Contract

50. Completion
51. Taking Over
52. Final Account
53. Operating and Maintenance Manuals
54. Termination
55. Payment upon Termination
56. Property
57. Release from Performance
58. Approval of architectural plan

F. Special Conditions of Contract

CONDITIONS OF CONTRACT

A. GENERAL

1. Definitions

- 1.1.** Terms, which are defined in the Contract Data and not defined in the Conditions of Contract shall keep their defined meanings. Capital initials are used to identify defined terms.
- 1.1.1** **Bill of Quantities** means the priced and completed Bill of Quantities;
- 1.1.2** **Compensation Events** are those defined in Clause 41 hereunder;
- 1.1.3** The **Completion Date** is the date of completion of the Works as certified by the Engineer in accordance with sub-clause (1) of clause 50;
- 1.1.4** The **Contract** is the contract between the Employer and the Contractor to execute, complete and maintain the Works. It consists of the documents listed in Clause 2.3 below.
- 1.1.5** The **Contract Data** defines the documents and other information, which comprise the Contract;
- 1.1.6** The **Contractor** is a person or corporate body whose Bid to carry out the Works has been accepted by the Employer;
- 1.1.7** The **Contractor's Bid** is the completed Bidding document submitted by the Contractor to the Employer and includes Technical and Financial bids;
- 1.1.8** The **Contract Price** is the price stated in the Letter of Acceptance and thereafter as adjusted in accordance with the provisions of the Contract;
- 1.1.9** **Days** are calendar days; months are calendar months;
- 1.1.10** A **Defect** is any part of the Works not completed in accordance with the Contract;
- 1.1.11** The **Defects Liability Period** is the period named in the Contract Data and calculated from the Completion Date;
- 1.1.12** The **Employer** is the party who will employ the Contractor to carry out the Works;
- 1.1.13** **The Engineer** is the person named in the Contract Data (or any other competent person appointed and notified to the contractor to act in replacement of the Engineer) who is responsible for supervising the Contractor's work, administering the Contract, certifying payments due to the Contractor, issuing and valuing Variations to the Contract, recommending extensions of time, and valuing the Compensation Events;
- 1.1.14** **Equipment** is the Contractor's machinery and vehicles brought temporarily to the Site to construct the Works;
- 1.1.15** **Initial Contract Price** is the Contract Price listed in the Employer's Letter of Acceptance;
- 1.1.16** **Intended Completion Date** is the date on which it is intended that the Contractor shall complete the Works. The Intended Completion Date is specified in the Contract Data. The Intended Completion Date may be revised only by the Employer by issuing an extension of time;
- 1.1.17** **Materials** are all supplies, including consumables, used by the contractor for incorporation in the Works;
- 1.1.18** **Plant** is any integral part of the Works, which is to have a mechanical, electrical, electronic or chemical or biological function;
- 1.1.19** The **Site** is the area defined as such in the Contract Data;

- 1.1.20 Site Investigation Reports** are those, which were included in the Bidding documents and are factual interpretative reports about the surface and sub-surface conditions at the site;
- 1.1.21 Specification** means the Specification of the works included in the Contract and any modification or addition made or approved by the Employer;
- 1.1.22 The t Date / Date of Commencement** is given in the Contract Data. It is the date when the Contractor shall commence execution of the works. It does not necessarily coincide with any of the Site Possession Dates;
- 1.1.23 A Subcontractor** is a person or corporate body who has a Contract with the Contractor to carry out a part of the work in the Contract, which includes work on the Site;
- 1.1.24 Temporary Works** are works designed, constructed, installed, and removed by the Contractor, which are needed for construction or installation of the Works;
- 1.1.25 A Variation or Change in Scope** is an instruction given by the Employer, which varies and change the scope of Works;
- 1.1.26 Works** are what the Contract requires the Contractor to construct, install, and turn over to the Employer, as defined in the Contract Data;
- 1.1.27** Year may be understood as financial year;

2. Interpretation

- 2.1.** In interpreting the Conditions of Contract, singular also means plural, male also means female or neuter, and the other way around. Headings have no significance. Words have their general meaning under the language of the Contract unless specifically defined. The Employer will provide instructions clarifying queries about the Conditions of Contract.
- 2.2.** If sectional completion is specified in the Contract Data, references in the Conditions of Contract to the Works, the Completion Date, and the Intended Completion Date apply to any Section of the Works (other than references to the Completion Date and Intended Completion date for the whole of the Works).
- 2.3.** The documents forming the Contract shall be interpreted in the following order of priority:
- a) Agreement
 - b) Letter of Acceptance, notice to proceed with the works
 - c) Contractor's Bid
 - d) Contract Data
 - e) Conditions of Contract including Special Conditions of Contract
 - f) Specifications
 - g) Drawings
 - h) Bill of quantities (optional) and
 - i) Any other document listed in the Contract Data as forming part of the Contract.

3. Languages and Law

The language of the Contract and the law governing the Contract are stated in the Contract Data.

4. Employers' Decisions:

Except where otherwise specifically stated, the Engineer will decide contractual matters between the Employer and the Contractor in the role representing the Employer as per the provision of the contract.

5. Delegation:

The **Employer** may delegate any of his duties and responsibilities to other people after notifying the Contractor and may cancel any delegation after notifying the Contractor.

6. Communications:

Communications between parties which are referred to in the conditions are effective only when in writing. A notice shall be effective only when it is delivered (in terms of Indian Contract Act).

7. Sub-contracting:

The Contractor may sub-contract any portion of work, up to a limit specified in Contract Data, with the approval of the Engineer but may not assign the Contract without the approval of the Employer in writing. Sub-contracting does not alter the Contractor's obligations.

8. Other Contractors:

The Contractor shall cooperate and share the Site with other contractors, public authorities, utilities, and the Employer between the dates given in the Schedule of other Contractors. The Contractor shall as refer to in the Contract Data, also provide facilities and services for them as described in the Schedule. The employer may modify the schedule of other contractors and shall notify the contractor of any such modification.

9. Personnel:

9.1. The Contractor shall employ the key personnel named in the Schedule of Key Personnel as referred to in the Contract Data besides those as listed at section-8 and Section-9 to carry out the functions stated in the Schedule or other personnel approved by the Engineer. The Engineer will approve any proposed replacement of key personnel only if their qualifications, abilities, and relevant experience are substantially equal to or better than those of the personnel listed in the Schedule.

9.2. If the **Employer** asks the Contractor to remove a person who is a member of the Contractor's staff or his work force stating the reasons the Contractor shall ensure that the person leaves the Site within seven days and has no further connection with the work in the Contract.

10. Employer's and Contractor's Risks:

The Employer carries the risks which this Contract states are Employer's risks, and the Contractor carries the risks which this Contract states are Contractor's risks.

11. Employer's Risks:

The Employer is responsible for the excepted risks which are in so far as they directly affect the execution of the Works in India, the risks of war, hostilities, invasion, act of foreign enemies, rebellion, revolution, insurrection or military or usurped power, civil war, riot commotion or disorder (unless restricted to the Contractor's employees), and contamination from any nuclear fuel or nuclear waste or radioactive toxic explosive.

12. Contractor's Risks:

All risks of loss of or damage to physical property and of personal injury and death which arise during and in consequence of the performance of the Contract other than the excepted risks are the responsibility of the Contractor.

13. Insurance:

13.1 The Contractor shall provide, in the joint names of the Employer and the Contractor, insurance cover **for the period as stated below against the events and** in the amounts and

deductibles stated in the Contract Data for the following events which are due to the Contractor's risks:

A) From the starting date to the end of defect liability period:

Loss of or damage to the works

B) From the start date till completion of the work as per agreement:

- a) Loss of or damage to plant, materials and equipment,
- b) Loss of or damage of property (except the works, plant, materials and equipment) in connection with the contract, and
- c) Personal injury or death.

13.2 If all the items as listed at Cl.13.1(B) can be combined / grouped under one insurance cover like Contractor's All Risks (CAR) Policy, then the same is acceptable.

13.3 Prior to seven days before the start date, the Contractor shall furnish to the Engineer notarized true copies of the certificates of insurance, copies of insurance policies and premia payment receipts in respect of such insurance for the Employer's approval. All such insurance shall provide for compensation to be payable in the types and proportions of currencies required to rectify the loss or damage incurred.

13.4 If the contractor does not provide any of the policies and certificates required, the Employer may affect the insurance which the contractor should have provided and recover the premiums the Employer has paid from payments otherwise due to the contractor or, if no payment is due, the payment of the premiums shall be a debt due.

13.5 Alterations to the terms of insurance shall not be made without the approval of the Employer.

13.6 Both parties shall comply with any conditions of the insurance policies.

14. Site Investigation Reports:

The Contractor, in preparing the Bid, may rely on any site Investigation Reports referred to in the Contract Data, which are indicative and not exhaustive. The Employer shall provide all available details to the Contractor (Bidder) for his information, if requested by him at least one week prior to the bid submission date. The bidder shall be responsible for interpreting all such data. After award of work, the Contractor shall carryout detail survey and investigation for preparation of detail designs as per the scope of work and time period stipulated at Section-8.

To the extent which was practicable (taking account of cost and time), the Contractor (Bidder) shall be deemed to have obtained all necessary information as to risks, contingencies and other circumstances which may influence or affect the Tender or Works. To the same extent, the Contractor (Bidder) shall be deemed to have inspected and examined the Site, its surroundings, the above data and other available information, and to have been satisfied before submitting the Tender as to all relevant matters, including (without limitation):

- (a) the form and nature of the Site, including sub-surface conditions,
- (b) the climatic conditions,
- (c) the extent and nature of the work and Goods necessary for the execution and completion of the Works and the remedying of any defects,
- (d) the Laws, procedures and labour practices of the Country, and
- (e) the Contractor's requirements for access, accommodation, facilities, personnel, power, transport, water and other services.
- (f) availability of required materials

15. Queries about the Contract Data:

The Employer will clarify queries on the Contract Data if any during the Pre-bid meeting.

16. Contractor to Construct the Works:

The Contractor shall construct and install the Works in accordance with the approved specification and drawings. All designs, drawings and specifications to be furnished by the contractor shall be approved by the Employer before execution in accordance with Cl. 18.

17. The Works to be completed by the Intended Completion Date:

The Contractor may commence execution of the Works on the Start Date and shall carry out the Works in accordance with the programme submitted by the Contractor, as updated with the approval of the Engineer, and complete them by the Intended Completion Date.

18. Approval by the DFO:

18.1 The Contractor shall submit Specifications and Drawings showing the proposed Temporary Works to the DFO, who is to approve them if they comply with the Specifications and Drawings.

18.2 The Contractor shall be responsible for design of Temporary Works.

18.3 The DFO approval shall not alter the Contractor's responsibility for design of the Temporary Works.

18.4 The Contractor shall obtain approval to the design, drawings and specifications of all components of the building, except those for the temporary works as stated at Cl. 18.1, from any Institute of Repute at its own cost. Such approved documents need to be furnished to the Employer within the stipulated datelines as mentioned in the contract data and at Section-8.

18.5 All Drawings prepared by the Contractor for the execution of the temporary or permanent Works, are subject to prior approval by the Employer / Engineer before their use.

19. Safety:

The Contractor shall be responsible for the safety of all activities on the Site.

20. Discoveries:

Anything of historical or other interest or of significant value unexpectedly discovered on the Site is the property of the Employer. The Contractor is to notify the Engineer of such discoveries and carry out the Engineer's instructions for dealing with them.

21. Possession of the Site:

The Employer shall give possession of all parts of the Site to the Contractor. If possession of a part is not given by the date stated in the Contract Data the Employer is deemed to have delayed the start of the relevant activities and this will be Compensation Event.

22. Access to the Site:

The Contractor shall allow the Employer and any person authorized by the Employer access to the Site, to any place where work in connection with the Contract is being carried out or is intended to be carried out and to any place where materials or plant are being manufactured / fabricated / assembled for the works.

23. Instructions:

23.1 The Contractor shall carry out all instructions of the Engineer pertaining to works, which comply with the applicable laws where the Site is located.

23.2 The Contractor shall permit the Employer to inspect the Contractor's accounts and records relating to the performance of the Contractor and to have them audited by auditors appointed by the Employer, if so, required by the Employer.

24. Disputes:

That for the purpose of jurisdiction in the event of disputes if any of the Contract would be deemed to have been entered in to within the State of Odisha and it is agreed that neither party to the Contract will be competent to bring a suit in regard to the matter by this Contract at any place outside the State of Odisha.

25. Procedure for Settlement of Disputes:

In case of Dispute or difference arising between the Employer and the contractor relating to any matter arising out of or connected with this agreement, such disputes or difference shall be settled in accordance with the Arbitration and Conciliation Act, 1996.

26. Replacement of Adjudicator: Not applicable

B. TIME CONTROL

27. Programme :

27.1 Within 14 days of issue of letter of award, the successful bidder shall submit to the Employer detail work programme for approval showing the general methods, arrangements, order and timing for all the activities in the Works along with monthly cash flow forecast. The agreed work programme / milestones during such contract negotiation shall form part of the agreement.

27.2 An update of the Programme shall be a programme showing the actual progress achieved on each activity and the effect of the progress achieved on the timing of the remaining work including any changes to the sequence of the activities.

27.3 The contractor shall submit to the Employer, for approval, an updated Programme at intervals no longer than the period stated in the Contract Data. If the Contractor does not submit an updated Programme within this period, the Engineer may withhold the amount stated in the Contract Data from the next payment certificate and continue to withhold this amount until the next payment after the date on which the overdue programme has been submitted.

27.4 The Employer's approval of the Programme shall not alter the Contractor's obligations. The Contractor may revise the Programme and submit it to the Employer again at any time. A revised Programme is to show the effect of Variations and Compensation Events.

28 Extension of the Intended Completion Date :

28.1 The Employer shall extend the Intended Completion Date if a Compensation Event occurs or a Variation is issued which makes it impossible for Completion to be achieved by the intended Completion Date without the Contractor taking steps to accelerate the remaining work and which would cause the Contractor to incur additional cost.

28.2. The Employer shall decide whether and by how much to extend the Intended Completion Date within 35 days of the Contractor asking the Engineer for a decision upon the effect of a Compensation Event or Variation and submitting full supporting information. If the Contractor has failed to give early warning of a delay or has failed to cooperate in dealing with a delay, the delay by this failure shall not be considered in assessing the new Intended Completion Date.

- 28.3. The Engineer/Employer shall within 14 days of receiving full justification from the contractor for extension of Intended Completion Date refer to the Employer his recommendation. The Employer shall in not more than 21 days communicate to the Engineer the Employer's decision.
29. Delays Ordered by the Divisional Forest Officer:
The Divisional Forest Officer may instruct the Contractor to delay the start or progress of any activity within the Works.
- 30. Management Meetings:**
- 30.1** Either the Divisional Forest Officer or the Contractor may require the other to attend a management meeting. The business of a management meeting shall be to review the plans for remaining work and to deal with matters raised in accordance with the early warning procedure.
- 30.2** The Divisional Forest Officer shall record the business of management meetings and is to provide copies of his record to those attending the meeting and to the Employer. The responsibility of the parties for actions to be taken is to be decided by the Divisional Forest Officer either at the management meeting or after the management meeting and stated in writing to all who attended the meeting.
- 31. Early Warning:**
- 31.1** The Contractor is to warn the Divisional Forest Officer at the earliest opportunity of specific likely future events or circumstances that may adversely affect the work resulting delay in the execution. The Divisional Forest Officer may require the Contractor to provide an estimate of the expected effect of the future event or circumstance on the Completion Date.
- 31.2** The Contractor shall cooperate with the Divisional Forest Officer in making and considering proposals for how the effect of such an event or circumstance can be avoided or reduced by anyone involved in the work and in carrying out any resulting instruction of the Divisional Forest Officer.

C. QUALITY CONTROL

32. Identifying Defects :

The Employer shall check the Contractor's work regularly and notify the Contractor of any Defects that are found. Such checking shall not affect the Contractor's responsibilities. The /Employer may instruct the Contractor to search for defects and to uncover and test any work that the /Employer considers may have a Defect

33. Tests:

If the Employer instructs the Contractor to carry out a test not specified in the Specification to check whether any work has a Defect and the test shows that it does, the Contractor shall pay for the test and any samples. If there is no Defect the test shall be a Compensation Event.

34. Correction of Defects:

34.1 The Employer shall give notice to the Contractor of any Defects before the end of the Defects Liability Period, which begins at Completion and is defined in the Contract Data. The Defects Liability Period shall be extended for as long as Defects remain to be corrected.

34.2 Every time notice of a Defect is given, the Contractor shall correct the notified Defect within the length of time specified by Employer's notice.

35. Uncorrected Defects:

If the Contractor has not corrected a Defect within the time specified in the Employer's notice, the Employer will assess the cost of having the Defect corrected, and the Contractor will pay this amount.

D. COST CONTROL

36. Changes in the Quantities: (OPTIONAL)

37. Change of Scope (Variations) and Procedure for change of Scope:

37.1. The Employer may, require the Contractor to make modifications/alterations to the construction works before the issue of the completion certificate either by giving an instruction or by requesting the contractor to submit a proposal for change of scope involving additional cost or reduction in cost. Any such change of scope shall be made and valued in accordance with the provisions of this contract and the contractor, in that event, will have no further claim on the ground that had it been known / disclosed earlier he would have made such charges in other connected work in their design, construction which would have saved him some cost and given him other consequential benefits.

37.2 Change in scope may include;

- (a) Change in specifications of any item of works
- (b) omission/ deletion of any item of work from the scope of work
- (c) any additional work (such as addition of extra plinth area) which are not included in the scope of work including any additional test on completion

37.3 In the event of the Employer determining that a change of scope is necessary, it shall issue notice to the contractor a notice specifying in reasonable detail the works contemplated there under ("Change of scope notice")

37.4 Upon receipt of change in scope notice, the contractor shall with due diligence, provide to the Employer within seven days' time such information as is necessary together with documentation in support of;

- (a) the impact, of any, which the change in scope is likely to have on the completion of the work
- (b) the options for implementing the proposed change of scope and the effect, if any, each on the cost and time thereof including the following details;
 - (i) breakdown of quantities, unit rates and cost for different items of work
 - (ii) proposed design for the change of scope
 - (iii) proposed modifications, if any, to the construction period with updated work programmes (all Variations shall be included in updated Programmes produced by the Contractor).

37.5 The contractor's quotation for change of scope shall be based on the detail design and rates for various item of works as derived on the basis of his original bid price (in case of repetition of similar item as per original contract) or CSR of the State and prevailing market rates (in case of new item not envisaged in the CSR)

37.6 The total value of all change of scope of work shall not exceed 5% of total contract price for the construction work.

38. Payments for Change of Scope (Variations):

38.1 The Employer shall assess the change in scope proposal and Contractor's quotation and upon reaching an agreement; the Employer shall issue the **Change Scope Order** requiring the contractor to proceed with the performance thereof.

38.2 If the Contractor's quotation is unreasonable, the Employer may order the Variation and make a change to the Contract Price which shall be based on Employer's own forecast of the effects of the Variation on the Contractor's costs.

38.3 If the Employer decides that the urgency of varying the work would prevent a quotation being given and considered without delaying the work, no quotation shall be given and the Variation shall be treated as a Compensation Event, subject to condition that such variation shall not exceed 5% of the total contract price for the contract work.

38.4 The Contractor shall not be entitled to additional payment for costs, which could have been avoided by giving early warning.

39. Payment Certificates:

39.1 The Contractor shall submit to the Employer statements of the value of the work completed.

39.2 The Employer shall check the Contractor's statement within 14 days and certify the amount to be paid to the Contractor as per contract payment schedule after taking into account any credit or - debit for the month in question in respect of materials for the works in the relevant amounts and under conditions set forth in sub-clause 47.3 of the Contract Data (Secured Advance).

39.3 The value of work executed shall be determined by the Employer.

39.4 The value of work executed shall comprise the value of the quantities of the items as per the mile stone and work programme attached to the contract.

39.5 The value of work executed shall include the valuation of Change in Scope (Variation) and Compensation Events, if any.

39.6 The Employer/Officer may exclude any item certified in a previous certificate or reduce the proportion of any item previously certified in any certificate in the light of later information.

40. Payments:

Payments shall be adjusted for deductions for retention, other recoveries in terms of the contract and taxes at source, as applicable under the law. The Divisional Forest Officer shall pay the Contractor the amounts as per the payment schedule attached to the contract.

41. Compensation Events:

41.1 The following are Compensation Events unless they are caused by the Contractor:

- (a) The Employer does not give access to a part of the Site by the Site Possession Date stated in the Contract Data.
- (b) Other contractors, public authorities of utilities or the Employer does not work within the dates and other constraints stated in the Contract, and they cause delay or extra cost to the Contractor.

41.2 If a Compensation Event would prevent the work being completed before the Intended Completion Date, the Intended Completion Date shall be extended. The Contractor will react competently and promptly to the event and shall submit information demonstrating the effect of the Compensation Event and the required extended time period for completion.

41.3 The Employer shall examine the information furnished by the Contractor and shall recommend to the Employer by how much time the Intended Completion Date shall be extended. The Employer shall decide / sanction the required extension of time due to such compensation event.

41.4 The Contractor shall not be entitled to compensation to the extent that the Employer's interests are adversely affected by the Contractor not having given early warning or not having cooperated with the Divisional Forest Officer.

42. Tax:

The rates quoted by the Contractor shall be deemed to be inclusive of Royalty, Income Tax, Labour CESS, GST to be paid as applicable and all other statutory taxes that the Contractor will

have to pay for the performance of this Contract. The Employer will perform such duties in regard to the deduction of such taxes at source as per applicable law.

43. Currencies:

All payments shall be made-in Indian Rupees.

44. Retention:

44.1 The Employer shall retain from each payment due to the Contractor the proportion stated in the Contract Data until Completion of the whole of the works or settlement of final payment.

44.2 On completion of the whole of the works half the total amount retained is repaid to the contractor and half when the Defects Liability Period has passed and the Employer has certified that all defects notified by the Employer to the contractor before the end of the period have been corrected.

45. Liquidated Damages:

45.1 The Contractor shall pay liquidated damages to the Employer at the rate per week stated in the Contract Data for each week that the Completion Date is later than the Intended Completion Date (for the whole of the works or the milestone as stated in the contract data). The total amount of liquidated damages shall not exceed the amount defined in the Contract Data. The Employer may deduct liquidated damages from payments due to the Contractor. Payment of liquidated damages shall not relieve the contractor from his / her / their obligation to complete the works or from any other duties, obligations or responsibilities which he / she / they may have under the contract.

45.2 If the Intended Completion Date is extended after liquidated damages have been paid, the Officer/Employer shall correct any overpayment of liquidated damages by the Contractor by adjusting the next payment certificate.

45.3 If the contractor fails to comply with the time for completion as stipulated in the tender, then the contractor shall pay to the employer the relevant sum stated in the Contract Data as Liquidated damages for such default and not as penalty for every week or part of week which shall elapse between relevant time for completion and the date stated in the taking over certificate of the whole of the works on the relevant section, subject to the limit stated in the contract data.

The employer may, without prejudice to any other method of recovery deduct the amount of such damages from any money due or to become due to the contractor. The payment or deduction of such damages shall not relieve the contractor from his obligation to complete the works or from any other of his obligations and liabilities under the contract.

45.4 If, before the Time for Completion of the whole of the Works or, if applicable, any Section, a Taking - Over Certificate has been issued for any part of the Works or of a Section, the liquidated damages for delay in completion of the remainder of the Works or of that Section shall, for any period of delay after the date stated in such Taking-Over Certificate, and in the absence of alternative provisions in the Contract, be reduced in the proportion which the value of the part so certified bears to the value of the whole of the Works or Section, as applicable. The provisions of this Sub-Clause shall only apply to the rate of liquidated damages and shall not affect the limit thereof.

46. Bonus Payment:

46.1 The procedure for payment of bonus (incentive) shall be as per the latest amendment to Para 3.5.5 of OPWD code, Vol-I.

46.2 If the contractor achieves completion of the whole of the works prior to the Intended Completion Date prescribed in Contract Data the Employer shall pay to the contractor a sum

stated in Contract Data as bonus (incentive) for every completed month which shall elapse between the date of completion of all items of works as stipulated in the Contract and the time prescribed in Clause 17.

46.3 For the purpose of calculating bonus payments, the time given in the Bid for completion of the whole of the works is fixed and unless otherwise agreed, no adjustments of the time by reason of granting an extension of time pursuant to Clause 28 or any other clause of these conditions will be allowed. Any period falling short of a complete month shall be ignored for the purpose of computing the period relevant for the payment of bonus.

47. Advance Payment (Mobilisation and machinery advance):

47.1 The Divisional Forest Officer shall make advance payment to the Contractor for mobilization and cash flow support of the amounts stated in the Contract Data by the date stated in the Contract Data, only against provision by the Contractor of an Unconditional Bank Guarantee in a form and by a Bank acceptable to the Divisional Forest Officer in amounts and currencies equal to the advance payment.

47.2 An interest @ 10% per annum shall be charged on the advance payment.

47.3 The Advance Payment shall not be released until the design is finalized and establishment of camp at work site is completed.

47.4 The guarantee shall remain effective until the advance payment has been repaid, but the amount of the guarantee shall be progressively reduced by the amounts repaid by the Contractor. The contractor shall ensure that the Bank Guarantee remain enforceable until the advance payment has been fully repaid and accordingly renew it, from time to time, until the advance payment has been fully repaid.

47.5 If the terms of guarantee specify its expiry date, and the advance payment has not been re-paid by the date then 28 days prior to the expiry date, the contractor shall extend the validity of the guarantee until the advance payment has been fully repaid.

47.6 The advance payment shall be repaid through percentage deductions from the interim payments as follows: -

a) Deductions shall commence from the 1st interim payment.

b) Deductions shall be made in proportions of the advance payment until such time as the advance payment has been repaid: provided that the advance payment shall be completely repaid prior to the time when 90 percent of the accepted contract amount has been repaid.

47.7 If the advance payment has not been repaid prior to the issue of the Taking over Certificate for the work or prior to termination under Section – 3 Clause -54 of (termination by employer), the balance advance is payable by the contractor to the employer.

48. Securities:

The Performance Security shall be provided to the Employer no later than the date specified in the Letter of Acceptance and shall be issued in an amount and form and by a bank or surety acceptable to the Employer, and denominated in Indian Rupees. The Performance Security shall be valid up to the **end of defect liability period**.

49. Cost of Repairs:

Loss or damage to the Works or Materials to be incorporated in the Works between the Start Date and the end of the Defects Correction periods shall be remedied by the Contractor at the Contractor's cost if the loss or damage arises from the Contractor's acts or omissions including the situation as stipulated at Cl. 12.

E. FINISHING THE CONTRACT

50. Completion:

The Contractor shall request the Divisional Forest Officer to issue a Certificate of Completion of the Works and the Divisional Forest Officer will do so upon deciding that the Work is completed.

51. Taking Over:

The Employer/officer shall take over the Site and the Works within seven days of the Divisional Forest Officer issuing a certificate of Completion.

52. Final Account :

The Contractor shall supply to the Divisional Forest Officer a detailed account of the total amount that the Contractor considers payable under the Contract before the end of the Defects Liability Period. The Divisional Forest Officer shall issue a Defect Liability Certificate and certify any final payment that is due to the Contractor within 56 days of receiving the Contractor's account if it is correct and complete. If it is not, the Divisional Forest Officer shall issue within 56 days a schedule that states the scope of the corrections or additions that are necessary. If the Final Account is still unsatisfactory after it has been resubmitted, the Employer shall decide on the amount payable to the Contractor and issue a payment certificate, within 56 days of receiving the Contractor's revised account.

53. Operating and Maintenance Manuals:

If "as built" Drawings and/or operating and maintenance manuals are required, the Contractor shall supply them by the dates stated in the Contract Data.

or

If the Contractor does not supply the Drawings and/or manuals by the dates stated in the Contract Data, or they do not receive the Employer's approval, the Divisional Forest Officer shall withhold the amount stated in the Contract Data from payments due to the Contractor.

54. Termination:

54.1 The Employer may terminate the Contract if the other party causes a fundamental breach of the Contract.

54.2 Fundamental breaches of Contract include, but shall not be limited to the following:

- (a) the Contractor stops work for 28 days when no stoppage of work is shown on the current Programme and the stoppage has not been authorized by the Divisional Forest Officer;
- (b) the Contractor is made bankrupt or goes into liquidation other than for a reconstruction or amalgamation;
- (c) the Officer/Divisional Forest Officer gives Notice that failure to correct a particular Defect is a fundamental breach of Contract and the Contractor fails to correct it within a reasonable period of time determined by the officer/Divisional Forest Officer;
- (d) the Contractor does not maintain a security which is required;
- (e) the Contractor has delayed the completion of works by the number of days for which the maximum amount of liquidated damages can be paid as defined in the Contract data; and
- (f) if the Contractor, in the judgment of the Employer has engaged in corrupt or fraudulent practices in competing for or in executing the Contract.

For the purpose of this paragraph: "corrupt practice" means the offering, giving, receiving or soliciting of anything of value to influence the action of a public official in the procurement process or in contract execution. "Fraudulent practice" means a misrepresentation of facts in

order to influence a procurement process or the execution of a contract to the detriment of the Borrower, and includes collusive practice among Bidders (prior to or after bid submission) designed to establish bid prices at artificial non-competitive levels and to deprive the Borrower of the benefits of free and open competition."

54.3 When either party to the Contract gives notice of a breach of contract to the Divisional Forest Officer for a cause other than those listed under Sub Clause 54.2 above, the Divisional Forest Officer shall decide whether the breach is fundamental or not.

54.4 Notwithstanding the above, the Employer may terminate the Contract for convenience.

54.5 If the Contract is terminated the Contractor shall stop work immediately, make the Site safe and secure and leave the Site, as soon as reasonably possible.

55. Payment upon Termination:

55.1 If the Contract is terminated because of a fundamental breach of Contract by the Contractor, the Divisional Forest Officer shall issue a certificate for the value of the work done less advance payments received up to the date of the issue of the certificate, less other recoveries due in terms of the contract, less taxes due to be deducted at source as per applicable law and less the percentage to apply to the work not completed as indicated in the Contract Data. Additional Liquidated Damages shall not apply. If the total amount due to the Employer exceeds any payment due to the Contractor, the difference shall be a debt payable to the Employer.

55.2 If the Contract is terminated at the Employer's convenience, the Divisional Forest Officer shall issue a certificate for the value of the work done, less advance payments received up to the date of the certificate, less other recoveries due in terms of the contract and less taxes due to be deducted at source as per applicable law. No extra cost will be paid by the employer for expenditure towards removal of Equipment, repatriation of the Contractor's personnel employed solely on the Works and the Contractor's costs of protecting and securing the Works.

56. Property:

All materials on the Site, Plant, Equipment, Temporary Works and Works are deemed to be the property of the Employer, if the Contract is terminated because of a Contractor's default.

57. Release from Performance :

57.1 If the Contract is frustrated by the outbreak of war or by any other event entirely outside the control of either the Employer or the Contractor, the Divisional Forest Officer shall certify that the Contract has been frustrated. The Contractor shall make the Site safe and stop work as quickly as possible after receiving this certificate and shall be paid for all work carried out before receiving it and for any work carried out afterwards to which commitment was made.

58. Approval of Architectural Plans :

58.1 All architectural plans shall be approved by the bidders at his own cost from concerned development authorities within stipulated time.

58.2 Compliance with environmental and energy efficiency norms and obtaining at least 4-star GRIHA rating.

F. Special Conditions of Contract

1. LABOUR :

The Contractor shall, unless otherwise provided in the Contract, make his own arrangements for the engagement of all staff and labour, local or other, and for their payment, housing, feeding and transport.

The Contractor shall, if required by the Divisional Forest Officer, deliver to the Divisional Forest Officer a return in detail, in such form and at such intervals as the Divisional Forest Officer may prescribe, showing the staff and the numbers of the several classes of labour from time to time employed by the Contractor on the Site and such other information as the Divisional Forest Officer may require.

2. COMPLIANCE WITH LABOUR REGULATIONS :

During continuance of the contract, the Contractor and his sub-contractors shall abide at all times by all existing labour enactments and rules made there under, regulations, notifications and bye laws of the State or Central Government or local authority and any other labour law (including rules), regulations, bye laws that may be passed or notification that may be issued under any labour law in future either by the State or the Central Government or the local authority. Salient features of some of the major labour laws that are applicable to construction industry are given below. The Contractor shall keep the Employer indemnified in case any action is taken against the Employer by the competent authority on account of contravention of any of the provisions of any Act or rules made there under, regulations or notifications including amendments. If the Employer is caused to pay or reimburse, such amounts as may be necessary to cause or observe, or for non-observance of the provisions stipulated in the notifications/bye laws/Acts/Rules/regulations including amendments, if any, on the part of the Contractor, the Divisional Forest Officer/Employer shall have the right to deduct any money due to the Contractor including his amount of performance security. The Employer/ Divisional Forest Officer shall also have right to recover from the Contractor any sum required or estimated to be required for making good the loss or damage suffered by the Employer.

The employees of the Contractor and the Sub-Contractor in no case shall be treated as the employees of the Employer at any point of time.

SALIENT FEATURES OF SOME MAJOR LABOUR LAWS APPLICABLE TO ESTABLISHMENTS ENGAGED IN BUILDING AND OTHER CONSTRUCTION WORK.

- a) Workmen Compensation Act 1923:- The Act provides for compensation in case of injury by accident arising out of and during the course of employment.
- b) Payment of Gratuity Act 1972:- Gratuity is payable to an employee under the Act on satisfaction of certain conditions on separation if an employee has completed 5 years service or more or on death the rate of 15 days wages for every completed year of service. The Act is applicable to all establishments employing 10 or more employees.
- c) Employees P.F. and Miscellaneous Provision Act 1952: The Act Provides for monthly contributions by the employer plus workers @ 10% or 8.33%. The benefits payable under the Act are:
 - (i) Pension or family pension on retirement or death, as the case may be.
 - (ii) Deposit linked insurance on the death in harness of the worker.
 - (iii) Payment of P.F. accumulation on retirement/death etc.
- d) Maternity Benefit Act 1951:- The Act provides for leave and some other benefits to women employees in case of confinement or miscarriage etc.
- e) Contract Labour (Regulation & Abolition) Act 1970:- The Act provides for certain welfare measures to be provided by the Contractor to contract labour and in case the Contractor fails to provide, the same are required to be provided, by the Principal Employer by Law. The Principal Employer is required to take Certificate of Registration and the Contractor is required to take license from the designated Officer. The Act is applicable to the establishments or Contractor of Principal Employer if they employ 20 or more contract labour.

- f) Minimum Wages Act 1948:- The Employer is supposed to pay not less than the Minimum Wages fixed by appropriate Government as per provisions of the Act if the employment is a scheduled employment. Construction of Buildings, Roads, Runways are scheduled employments.
- g) Payment of Wages Act 1936:- It lays down as to by what date the wages are to be paid, when it will be paid and what deductions can be made from the wages of the workers.
- h) Equal Remuneration Act 1979:- The Act provides for payment of equal wages for work of equal nature to Male and Female workers and for not making discrimination against Female employees in the matters of transfers, training and promotions etc.
- i) Payment of Bonus Act 1965:- The Act is applicable to all establishments employing 20 or more employees. The Act provides for payments of annual bonus subject to a minimum of 8.33% of wages and maximum of 20% of wages to employees drawing Rs.3500/-per month or less. The bonus to be paid to employees getting Rs.2500/- per month or above up to Rs.3500/- per month shall be worked out by taking wages as Rs.2500/-per month only. The Act does not apply to certain establishments. The newly set-up establishments are exempted for five years in certain circumstances. Some of the State Governments have reduced the employment size from 20 to 10 for the purpose of applicability of this Act.
- j) Industrial Disputes Act 1947:- The Act lays down the machinery and procedure for resolution of Industrial disputes, in what situations a strike or lock-out becomes illegal and what are the requirements for laying off or retrenching the employees or closing down the establishment.
- k) Industrial Employment (Standing Orders) Act 1946:- It is applicable to all establishments employing 100 or more workmen (employment size reduced by some of the States and Central Government to 50). The Act provides for laying down rules governing the conditions of employment by the Employer on matters provided in the Act and get the same certified by the designated Authority.
- l) Trade Unions Act 1926:- The Act lays down the procedure for registration of trade unions of workmen and employers. The Trade Unions registered under the Act have been given certain immunities from civil and criminal liabilities.
- m) Child Labour (Prohibition & Regulation) Act 1986:- The Act prohibits employment of children below 14 years of age in certain occupations and processes and provides for regulation of employment of children in all other occupations and processes. Employment of Child Labour is prohibited in Building and Construction Industry.
- n) Inter-State Migrant workmen's (Regulation of Employment & Conditions of Service) Act 1979:- The Act is applicable to an establishment which employs 5 or more inter-state migrant workmen through an intermediary (who has recruited workmen in one state for employment in the establishment situated in another state). The Inter-State migrant workmen, in an establishment to which this Act becomes applicable, are required to be provided certain facilities such as housing, medical aid, travelling expenses from home upto the establishment and back, etc.
- o) The Building and Other Construction workers (Regulation of Employment and Conditions of Service) Act 1996 and the Cess Act of 1996:- All the establishments who carry on any building or other construction work and employs 10 or more workers are covered under this Act. All such establishments are required to pay cess at the rate not exceeding 2% of the cost of construction as may be modified by the Government. The Employer of the establishment is required to provide safety measures at the Building or construction work and other welfare measures, such as Canteens, First-Aid facilities, Ambulance, Housing accommodations for workers near the work place etc. The Employer to whom the Act applies has to obtain a registration certificate from the Registering Officer appointed by the Government.

- p) Factories Act 1948:- The Act lays down the procedure for approval at plans before setting up a factory, health and safety provisions, welfare provisions, working hours, annual earned leave and rendering information regarding accidents or dangerous occurrences to designated authorities. It is applicable to premises employing 10 persons or more with aid of power or 20 or more persons without the aid of power engaged in manufacturing process.

3. SUB-CONTRACTING (GCC Clause 7) :

Please add the following as Clause 7.2:

The contractor shall not be required to obtain any consent from the employer for:

- a) the Sub-contracting of any part of the works for which the sub-contractor is named in the contract;
- b) the provision of labour; and
- c) the purchase of materials which are in accordance with the standards specified in the Contract.
- d) Beyond this if the contractor proposes sub-contracting any part of the work during execution of works, because of some unforeseen circumstances to enable him to complete the work as per terms of the contract, the Divisional Forest Officer / Employer will consider the following before according approval:
 - The contractor shall not sub-contract the whole of the works.
 - The contractor shall not sub-contract any part of the work without prior consent of the Divisional Forest Officer. Any such consent shall not relieve at the contractor from any liability or obligations under the contract and he shall be responsible for the acts, defaults and neglects of any sub-contractor, his agents or workmen as fully as if they were the acts, defaults or neglects of the contractor, his agents or workmen.
 - The Divisional Forest Officer should satisfy whether (a) the circumstances warrant such sub-contracting; and (b) the sub-contractors so proposed for the work possess the experience, qualification and equipment necessary for the job proposed to be entrusted to them in proportion to the quantum of work to be sub-contracted.
 - If payments are proposed to be made directly to that sub-contractor, this should be subject to specific authorization by the prime contractor so that this arrangement does not alter the contractor's liability or obligations under the contract.

Note : All bidders are expected to indicate clearly in the bid, if they proposed sub-contracting elements of the works amounting to more than 20 percent of the Bid Price. For each such proposal the qualification and the experience of the identified sub-contractor in the relevant field should be furnished along with the bid to enable the employer to satisfy himself about their qualifications before agreeing for such sub-contracting and include it in the contract.

In view of the above, normally no additional sub-contracting should arise during execution of the contract.

4. PROTECTION OF ENVIRONMENT:

Add the following as GCC Clause 16.2:

The Contractor shall take all reasonable steps to protect the environment on and off the Site and to avoid damage or nuisance to persons or to property of the public or other resulting from pollution, noise or other causes arising as a consequence of his methods of operation.

During continuance of the contract, the Contractor and his sub-contractors shall abide at all times by all existing enactments on environmental protection and rules made there under, regulations, notifications and bye-laws of the State or Central Government, or local authorities and any other law, by-law, regulations that may be passed or notification that may be issued in this respect in future by the State or Central Government or the local authority. The contractor shall also abide by the requirements as per Attachment-X of the Bid Document.

Salient features of some of the major laws that are applicable are given below:

The Water (prevention and Control of Pollution) Act, 1974: This provides for the prevention and control of water pollution and the maintaining and restoring of wholesomeness of water. 'Pollution' means such contamination of water or such alteration of the physical, chemical or biological properties of water or such discharge of any sewage or trade effluent or of any other liquid, gaseous or solid substance into water (whether directly or indirectly) as may, or is likely to, create a nuisance or render such water harmful or injurious to public health or safety, or to domestic, commercial, industrial, agricultural or other legitimate uses, or to the life and health of animals or plants or of aquatic organisms.

The Air (prevention and Control of Pollution) Act, 1981: This provides for prevention, control and abatement of air pollution. 'Air Pollution' means the presence in the atmosphere of any 'air pollutant', which means any solid, liquid or gaseous substance (including noise) present in the atmosphere in such concentration as may be or tend to be injurious to human beings or other living creatures or plants or property or environment.

The Environment (Protection) Act, 1986: This provides for the protection and improvement of environment and for matters connected therewith, and the prevention of hazards to human beings, other living creatures, plants and property. 'Environment' includes water, air and land and the inter-relationship which exists among and between water, air and land, and human being, other living creatures, plants, micro-organism and property.

The public Liability Insurance Act, 1991: This provides for public liability insurance for the purpose of providing immediate relief to the persons affected by accident occurring while handling hazardous substances and for matters connected herewith or incidental thereto. Hazardous substance means any substance or preparation which is defined as hazardous substance under the Environment (Protection) Act 1986, and exceeding such quantity as may be specified by notification by the Central Government.

5 Attachment - X

6 Environmental Mitigation Measures during Construction – ROAD AND BUILDINGS

| | Environmental Impact/Issue | Mitigation / Management Measures | Responsibility | |
|----|-----------------------------|--|----------------|-------------|
| | | | Implementation | Supervision |
| 1. | Removal of Trees | Trees will be removed from the corridor of impact (or, site) before the commencement of construction with prior clearance from the Forest Department. | Contractor | Department |
| 2. | Generation of Debris | Debris generated due to the dismantling of the existing pavement structure shall be suitably reused in the proposed construction, subject to the suitability of the material and the approval of the Divisional Forest Officer. Unutilisable debris material shall be suitably disposed off by the contractor, either for the filling up of borrow areas created for the project or at pre-designated dump locations. | Contractor | Department. |
| 3. | Loss of Topsoil | (a)The topsoil from all areas of cutting and all areas to be permanently covered shall be stripped to a specified depth of 150 mm and stored in stockpiles (maximum slope 1:2, and maximum height 2m). To retail soil and to allow percolation of water, the edges of the stockpile shall be protected by slit fencing (b)Stockpiles will not be surcharges or otherwise loaded and multiple handling will be kept to a minimum to ensure that no compaction will occur. It shall be ensured by the contractor that the topsoil will not be unnecessarily trafficked either before stripping or when in stockpiles. (c)Such stockpiled topsoil will be returned to cover the disturbed area and cut slopes. Residual topsoil will be distributed on adjoining/proximate barren/rocky areas as identified by the Divisional Forest Officer in a layer of thickness of 75 – 150 mm. Top soil shall also be utilized for redevelopment of borrow areas, landscaping along slopes, medians, incidental spaces etc. | Contractor | Department. |
| 4. | Borrowing of Earth | The borrowing shall not be carried out in cultivable lands, unless agreed upon by the Divisional Forest Officer. Borrowing of earth shall be carried out as per the IRC Guidelines. | Contractor | Department. |
| 5. | Degradation of Borrow Areas | The location, shape and size of the designated borrow areas shall be as approved by the Divisional Forest Officer and in accordance to the IRC recommended practice for borrow pits for road embankments. Borrow pits shall be re-developed, spoils shall be dumped with an overly of stockpiled topsoil. Redevelopment of borrow areas shall be taken up in accordance with the plans approved by the | Contractor | Department. |
| 6. | Soil Erosion | Along sections abutting water bodies, stone pitching needs to be carried out for slopes between 1:4 and 1:2 Gabion structures/ Grass turfing shall be provided for slopes steeper than 1 vertical to 2 horizontal. The work shall consist of measures as per design or as directed by the Divisional Forest Officer to control soil erosion, sedimentation and water pollution, through use of berms, dikes, sediment basins, fiber mats, mulches, grasses, slope drains and other devices. | Contractor | Department. |

| | | | | |
|-----|---|--|----------------|-------------|
| 7. | Construction Wastes & their disposal | Spoil from excavation of riverbed shall be managed and disposed off as directed by the Divisional Forest Officer. No new disposal site shall be created as part of the project, which is not redeveloped. All waste material shall be completely disposed as desired and the site shall be fully cleaned before handing over. | Contractor | Department. |
| 8. | Quarry Operations | The Contractor shall open and use quarries, as per the Odisha Mining Rules. Alternatively the Contractor shall acquire the required material from quarries licensed by the OSPCB and having an approved redevelopment plan. | Contractor | Department. |
| | Environmental Impact/Issue | Mitigation / Management Measures | Responsibility | |
| 9. | Loss of Water Bodies | <p>a. Filling of surface water bodies shall be compensated by digging an equal volume of soil for water storage. Such dug-up soil shall be used for spreading as topsoil.</p> <p>b. Wherever earthwork is undertaken, the banks shall be protected by means as designed or as approved by the Divisional Forest Officer. Construction shall be carried out in a manner so that the side slopes are no steeper than 1:4, otherwise slope protection work shall be provided, as approved by the Divisional Forest Officer and as per item 6 of these specifications. For drains carrying run-off from the highways entering, into surface water bodies/channels, with a fall exceeding 1.5 m cascading or sedimentation traps shall be provided.</p> | Contractor | Department. |
| 10. | Loss of Other Water Sources | The replacement shall be ready prior to demolition / dismantling of the existing source. Any damage to the existing sources of water (hand pump, tube well etc.) shall be made good by the Contractor at his expense. | Contractor | Department. |
| 11. | Flooding | In addition to the design requirements, the contractor shall take all desired measures as directed by the Divisional Forest Officer to prevent temporary or permanent flooding of the site or any adjacent area. | Contractor | Department. |
| 12. | Alteration of Drainage | <p>a. In sections along water courses, and close to cross-drainage channels, earth, stone or any other construction materials or appendage shall be properly disposed off so as not to block the flow of water.</p> <p>b. All necessary measures shall be taken to prevent earthwork, stonework, materials and appendage as well as the method of operation from impending cross-drainage at rivers, streams, water canals and existing and existing irrigation and drainage systems.</p> | Contractor | Department. |
| 13. | Contamination from Construction Wastes, fuel and Lubricants | At construction vehicle parking locations and at fuel/lubricant storage sites, oil and grease traps shall be provided. Fuel storage shall be in proper bunded areas. The discharge standards promulgated under the Environmental Protection Act, 1986 shall be strictly adhered to. | Contractor | Department. |

| | | | | |
|-----|---|--|----------------|-------------|
| 14. | Sanitation and Waste disposal in construction camps | Construction labourers' camps shall be located at least 200 m away from the nearest habitation and as approved by the Divisional Forest Officer. The sewage system for a construction labourers' camp shall be designed, built and as per the Factories Act, 1948 and the Building and other Construction Workers (Regulation of Employment and Conditions of Service) Act, 1996. | Contractor | Department. |
| 15. | Generation of Dust | All vehicles delivering materials to the site shall be covered to avoid spillage of materials. Clearance shall be effected by manual sweeping and removal of debris, or, if so directed by the Divisional Forest Officer, by mechanical sweeping and cleaning equipment, an all dust, mud and other debris shall be removed | Contractor | Department. |
| 16. | Emission from Hot-Mix Plants and Batching Plants. | Hot mix plants and batching plants shall be located sufficiently away from habitation, agricultural operations or industrial establishments. Where possible such plants will be located at least 1000 m downwind from the nearest habitation. The exhaust gases, and operation of the plants shall comply with the requirements of the relevant current emission control rules (as per OSPCB). | Contractor | Department. |
| | Environmental Impact/Issue | Mitigation / Management Measures | Responsibility | |
| 17. | Emission and noise from Vehicles & Equipment | All vehicles, equipment and machinery used for construction shall conform to the relevant Bureau of Indian Standard (BIS) norms. All vehicles, equipment and machinery used for construction shall be regularly maintained to ensure that pollution emission levels comply with the relevant requirements of OSPCB. | Contractor | Department. |
| 18. | Pollution from Crusher | All crushers used in construction shall conform to relevant dust emission control rules. Clearance for siting shall be obtained from the OSPCB. Alternatively, only crushers already licensed by the OSPCB shall be used. | Contractor | Department. |
| 19. | Loss, Damage or Disruption of/to Fauna. | All works are to be carried out in such a fashion that the damage and disruption to fauna is minimum. Construction workers shall be instructed to protect natural resources and fauna, including wild animals and aquatic life. Hunting and unauthorized fishing are prohibited. | Contractor | Department. |
| 20. | Chance-found important Flora/Fauna. | If a rare/endangered/threatened flora/fauna species is spotted, the contractor shall make all arrangements to intimate the Forest/Wildlife authorities without delay, and measures will be taken for its conservation. Work would be suspended, until the relevant authorities are consulted, unless specifically directly by the Divisional Forest Officer. | Contractor | Department. |
| 21. | Traffic Control and Safety | The Contractor shall take all necessary measures for the safety of traffic during construction and provide, erect and maintain such barricades, including signs, markings, flags, lights and flagmen as may be required by the Divisional Forest Officer for the information and protection of traffic approaching or passing through the section of the road under improvement. | Contractor | Department. |
| 22. | Risk from | The contractor is required to comply with all the precautions as required for the safety of the workmen as | Contractor | Department. |

| | | | | |
|-----|--|--|------------|-------------|
| | Construction Operations | per the international Labour Organisation (ILO) Convention No. 62 as far as those are applicable to this contract. The contractor shall also comply with the national Building Code for this purpose. | | |
| 23. | Potable Water and Hygiene | Potable water supply will be provided, at every workplace, as per the Factory Rules of Odisha. All requirements as per standards set by the Building and other Construction Workers (Regulation of Employment and Conditions of Service) Act, 1996 shall be fulfilled. | Contractor | Department. |
| 24. | Protection of Cultural Heritage / Property | All the necessary and adequate care shall be taken to minimize impact on cultural properties (which includes cultural sites and remains, places of worship, graveyards, monuments and any other important properties/sites/remains notified under the Ancient Sites and Remains Act) | Contractor | Department. |
| 25. | Chance found Archaeological property | All fossils, coins, articles of value of antiquity and structures and other remains or things of geological or archaeological interest discovered on the site shall be the property of the Government. The contractor shall all work within 100 m in all directions from the site. The Divisional Forest Officer shall seek direction from the Archaeological Society of India (ASI) before instructing the Contractor to recommence work on | Contractor | Department. |
| 26. | Risk from explosives | Except as may be provided in the contract or ordered or authorized by the Divisional Forest Officer, the contractor shall not use explosives. Where the use of explosives is so provided or ordered or authorized, the contractor shall comply with the requirements of the explosives Act. First aid and medical care shall be provided, as per the factory Rules of Odisha. | Contractor | Department. |

ARBITRATION (GCC Clause 25)

The procedure for arbitration will be as follows:

- 25 (a) In case of Dispute or difference arising between the Employer and a domestic contractor relating to any matter arising out of or connected with this agreement, such disputes or difference shall be settled in accordance with the Arbitration and Conciliation Act, 1996. The parties shall make efforts to agree on a sole arbitrator and only if such an attempt dose not succeed and the Arbitral Tribunal consisting of 3 arbitrators one each to be appointed by the Employer and the Contractor and the third Arbitrator to be chosen by the two Arbitrators so appointed by the Parties to act as Presiding Arbitrator shall be considered. In case of failure of the two arbitrators appointed by the parties to reach upon a consensus within a period of 30 days from the appointment of the arbitrator appointed subsequently, the Presiding Arbitrator shall be appointed by the *Council, Indian Road Congress.
- (b) The Arbitral Tribunal shall consist of three Arbitrators one each to be appointed by the Employer and the Contractor. The third Arbitrator shall be chosen by the two Arbitrators so appointed by the Parties, and shall act as Presiding arbitrator. In case of failure of the two arbitrators appointed by the parties to reach upon a consensus within a period of 30 days from the appointment of the arbitrator appointed subsequently, the Presiding arbitrator shall be appointed by the * Council, Indian Road Congress.
- (c) If one of the parties fails to appoint its arbitrator in pursuance of sub clause (a) and (b) above within 30 days after receipt of the notice of the appointment of its arbitrator by the other party, then the * Council, Indian Roads Congress shall appoint the arbitrator. A certified copy of the order of the Council, Indian Roads Congress making such an appointment shall be furnished to each of the parties.
- (d) Arbitration proceedings shall be held **in Puri**, and the language of the arbitrator proceedings and that of all documents and communications between the parties shall be English.
- (e) The decision of the majority of arbitrators shall be final and binding upon both parties. The cost and expenses of Arbitration proceedings will be paid as determined by the arbitral tribunal. However, the expenses incurred by each party in connection with the preparation, presentation, etc. of its proceedings as also the fees and expenses paid to the arbitrator appointed by such party or on its behalf shall be borne by each party itself.
- (f) Performance under the contract shall continue during the arbitration proceedings and payments due to the contractor by the owners shall not be withheld, unless they are the subject matter of the arbitration proceedings.

**SECTION 4:
CONTRACT DATA**

CONTRACT DATA

Items marked "N/A" do not apply in this Contract.

The following documents are also part of the Contract:

Clause Reference

- The Schedule of Operating and Maintenance Manuals [53]
- The Schedule of Other Contractors [8]
- The Schedule of Key Personnel [9]
- The Methodology and Program of construction [27]
- The Schedule of Key and Critical equipment to be deployed on the work as per agreed program of construction [27]
- Site Investigation reports [14]

The Employer is [Divisional Forest Officer, Puri Wildlife Division, Puri]

The Site is located at [Puri] [1]

Name of authorized Representative: [To be Notified Later] [1.1]

Name:

Address:

The name and identification number of the Contract [To be inserted later] [1.1]

The Works consist of: [Refer the site plan, technical specifications etc. attached at Section-7]

The Start Date /Commencement Date: - Date of issue of notice to proceed with the work.

The Intended Completion Date for the whole of the Works [24 Months]

This period includes the time period for survey, investigation and detail design as per the scope of services described at Section-8

The following documents also form part of the Contract: [2.3]

- i. NBC Specification Book of Latest Edition
- ii. Notice inviting bid including all corrigendum's / addendum / additional conditions / specifications / drawings etc. if any issued at the time of invitation of bid and acceptance thereof.
- iii. Bid document.
- iv. Performance security

The language of the Contract documents is English [3]

The law which applies to the Contract is the laws of Union of India [3]

Limit of subcontracting **20%** of the Initial Contract Price. [7.1]

Insurance requirements are as under: [13]

| Sl. No | Item | Minimum Cover for Insurance | Maximum deductible for Insurance |
|--------|------------------------------------|-----------------------------|----------------------------------|
| (i) | Works and Plant and Materials | Full | 0.45% of insured amount |
| (ii) | Loss of damage to Equipment | Full | 0.45% of insured amount |
| (iii) | Other Property | Camp Cost | 0.45% of insured amount |
| (iv) | Personal injury or death insurance | | |
| | a) For other people; | Rs.1,50,000.00 | As applicable |

| | | |
|--|-------------------------------|---|
| | b) For contractor's Employees | In accordance with the statutory requirements applicable to India |
|--|-------------------------------|---|

| | |
|--|----------------------|
| The duration of insurance- up to end of defect liability period | [13.1(A)] |
| The duration of insurance- up to end of completion period | [13.1(B)] |
| The Site Possession Date shall be simultaneously with the notice to proceed with the work: | [21] |
| The Contractor shall submit a Program for the Works within 7 days of delivery of the Letter of Acceptance of tender. | [27.1] |
| (This program should be in adequate detail and generally conform to the program submitted along with bid in response to ITB Clause 4.2 (K). deviations if any from that should be clearly explained and should be satisfactory to the Divisional Forest Officer) | |
| The period for submission of the programme for approval of Divisional Forest Officer Shall be 15 days from the date of issue of Letter of Acceptance | [27.1] |
| The period between Program updates shall be 30 days. | [27.2] |
| The amount to be withheld for late submission of an updated Program shall be 1% of the Contract Amount | [27.3] |
| The Defects Liability Period is Three Years from the date of certification of completion of work. | [34 & 35] |
| The currency of the Contract is Indian Rupees. | [43] |
| The rates and prices quoted by the bidder shall be fixed for the duration of the contract and shall not be subject to any adjustment | [37] |
| Retention money - 5 % of gross value of the bill] | [44] |
| The liquidated damages - 1% of the balance work per week subject to a maximum of 10% (ten percent) of the respective Contract Price. | [45] |

Mile Stones for Design Stage [insert mile stones as per the project requirement]

Illustrative Example

Mile Stone –1: Details of all Survey including laboratory test report.

: 15 days from the date of commencement as per agreement

Mile Stone–2: Draft Detail Drawings with Specifications & Methodology, approval from development authority, Urban Local Bodies, Fire Safety Officer.

: 30 days from date of date of commencement as per agreement

Mile Stone–3: Final Detail Design and Drawings with Specifications & Methodology and approval from GRIHA for green rating.

: 45 days from the date of commencement as per agreement

Mile Stones for Execution Stage [insert mile stones as per the project requirement]

Illustrative Example

Mile Stone–1: Completion of the work worth 15 percent of contract value on 25% time of execution stage.

Mile Stone–2: Completion of the work worth 40 percent of contract value on 50% time of execution stage.

Mile Stone–3: Completion of the work worth 75 percent of contract value on 75% time of execution stage.

Mile Stone–4: Completion of 100 percent (including final approval from development authority on as built drawing, fire fighting from fire officer, green rating from GRIHA, electrical equipments and HVAC equipments including approval from competent electrical authority) of contract value on 100% time of execution stage.

| | |
|---|--------|
| <u>Bonus Payment:</u> | [46] |
| 1% of contract Price in case of completion of work 3 months prior to completion date | |
| Maximum 2% of contract Price in case of completion of work 6 months prior to completion date | |
| Bonus payment for intermediate period shall be prorated as per Cl. 46.2 | |
| Advance payment [10% (ten percent) of the contract value] (Mobilisation and machinery advance) | [47] |
| Interest on Advance payment [10% (ten percent) per annum] | [47.2] |
| Validity of Performance Security - Up to the end of defect liability period | [48.1] |
| The amount to be withheld for failing to supply "as built" drawings (duly approved by appropriate authority) by the date required is Rs. 4.00 Lakh. | [53.1] |
| The following events shall also be fundamental breach of contract: | [54.2] |
| <ol style="list-style-type: none"> 1. The Contractor has contravened Sub-clause 7.1 and Clause 9.0 of GCC 2. The Contractor does not adhere to the agreed construction program (Clause 27 of GCC) and also fails to take satisfactory remedial action as per agreements reached in the management meetings (Clause 30) for a period of 60 days. | |
| The percentage to apply to the value of the work not completed representing the Employer's additional cost for completing the Works shall be - 20 % | [55.1] |

SECTION –5

TECHNICAL SPECIFICATIONS FOR ROAD AND BUILDING WORKS

PREAMBLE

Clause 5.1 The Technical specifications contained herein shall be read in conjunction with other documents of bid.

Clause 5.2 The technical specification in accordance with which the entire Work described there in after shall be carried out and completed by the contractor, shall comprise of the following

PART I: GENERAL TECHNICAL SPECIFICATIONS.

PART II: SUPPLEMENTARY TECHNICAL SPECIFICATIONS.

Clause 5.2.1 **PART I: GENERAL TECHNICAL SPECIFICATIONS**

The General Technical Specification shall be the **SPECIFICATIONS FOR BUILDING WORKS** as per NBC, IS-456, IS-800 and other relevant IS codes.

Clause 5.2.2. **PART II SUPPLEMENTARY TECHNICAL SPECIFICATIONS.**

The Supplementary Technical Specification shall comprise various Amendments/modifications/additions to the "Specifications for Building Works" referred to in Part-I above and Additional Specifications for particular item of work not already covered in Part-I.

Clause 5.2.2.1 A particular clause or a part there of in "Specifications for Building works" referred in Part-I above, where Amended/ Modified / Added upon, and incorporated under Part –II referred to above, such Amendments/ Modified/ additions/ supersede the relevant clause or part of the clause in part I referred to above.

Clause 5.2.2.2 The additional specifications comprise of specifications for particular item of works not already covered in Part-I.

Clause 5.2.2.3 When an Amended/ Modified/ added clause supersedes a clause or part thereof in the said specifications then any reference to the superseded clause shall be deemed to refer to the Amended/Modified/ Added Clause shall always prevail.

Clause 5.2.2.4 If so far any Amended/ Modified/ added clause may come in conflict or be inconsistent with any of the provisions of the said specifications under reference, the Amended/Modified/ Added Clause/latest edition of corresponding standards till 30 (thirty) days before the final date of submission of the tender shall always prevail.

Clause 5.3 **GENERAL TECHNICAL SPECIFICATIONS**

The SPECIFICATIONS FOR BUILDING WORKS" as per NBC, IS-456, IS-800 and other relevant IS codes. **Shall be deemed to be bound into this document.**

Note : In the absence of any definite provisions on any particular issue in the aforesaid specifications, reference may be made to the specifications of BIS Codes, where even the above codes are silent, the specifications of ODISHA P.W.D., IRRIGATION DEPARTMENT OR RURAL DEVELOPMENT Departmental specification approved from time to time by the concerned Chief Divisional Forest Officers shall apply. If none of the foregoing applies, the construction and completion of works shall conform to sound Engineering practice as approved by the Divisional Forest Officer in charge. In case of any dispute arising out of the interpretations of the above, the decision of the Divisional Forest Officer in charge shall be final and binding on the bidder.

TECHNICAL SPECIFICATION OF CIVIL PORTION OF WORK

- a) Pile foundation must be used in all building works including the foundation.
- b) Contractor will ensure 25% of the project cost is spent on the furnishing of the building including electronics with the approval of make and rates from the employer.
- c) The room height should not be less than 13 feet measured from any point from floor to clear roof;
- d) Corridors shall be at least 3 m wide to accommodate the daily traffic;
- e) The gradient and width of Ramps shall be of NBC-2016/latest NBC /NABH/IPH norms
- f) Infrastructure should be disabled and physically handicapped friendly as per the Rights of Persons with disabilities Act-2016 and CPWD Guidelines-1998(latest revised)
- g) Minimum clear distance between two beds should be minimum 1.5 m;
- h) Ramp, hand railing, proper lightening, anti-skid tiles must be provided in the Office
- i) HVAC filters (heating, ventilation, air conditioning) should be properly installed; and

The entrance point should have good access with adequate space for wheel chairs, stretchers, ramps etc

Materials of following specification are to be used in work. The Tenderer are expected to possess and be well conversant with the following IS standard and code of practice.

| | | |
|-----|--------------------------------------|--|
| 1. | Cement | Will be as per I.S. 269/255 (However the grade of cement to be selected by the Divisional Forest Officer of work and compressive cube test before commencement of work in each batch). |
| 2. | Steel | I.S. 432 (Plain) and 1786 (Tor) |
| 3. | Vibrator | I.S. 7246 |
| 4. | Aggregate | I.S. 383, I.S. 515 |
| 5. | Water for mixing and curing | Shall be clean, free from injurious amount of oil, salt, acid, vegetable materials and other substances and harmful to concrete in conformity to I.S. 456 and I.S. 2025. |
| 6. | Sand/ Fine Aggregate | I.S. 2116, 383 |
| 7. | Binding wire | I.S. 280 (galvanised minimum 1 mm) |
| 8. | Rain water pipe | I.S. 2527 |
| 9. | Construction joints | I.S. 3414 |
| 10. | Steel Window Frame | I.S. 1038/83 |
| 11. | Steel Door Frame | I.S. 4351/75 |
| 12. | Fitting & Fixtures for joinery works | Conforming to I.S. 7452/82 strictly conform to I.S. specification and as per direction of Divisional Forest Officer-in-Charge. |

Note : For road work (Approach Road) specification as per road and bridges (latest edition) published by I.R.C & M.O.S.T. shall be followed. In case of any doubt and absence of provision, regarding specification I.S. shall be referred (Indian standard).

ITEM OF WORK

1. Concrete shall be with conformity to I.S.456.
2. Foundation shall be with conformity to I.S.1080.
3. Stone masonry (R.R.) shall be with conformity to I.S.1597 (Part-I)
4. C.R. Masonry shall be with conformity to I.S.1597.
5. Brick masonry shall be with conformity to I.S.2212.
6. Cement plastering shall be with conformity to I.S.9103 & 6925.
7. Mortar shall be with conformity to I.S.2250
8. White and colour washing shall be with conformity to I.S.6278.
9. CC in foundation shall be with conformity to I.S.2571.
10. Anti-Termite Treatment shall be with conformity to I.S.6813. (Part – I & Part – II)
11. Painting to all surfaces shall be with conformity to I.S.2395 (Part – I & Part – II)
12. DPC shall be with conformity to I.S.3067
13. Tarfelt treatment shall be with conformity to I.S.1346
14. Mosaic flooring with conformity to I.S.2114
15. Steel painting shall be with conformity to I.S.1477 (Part – I & Part – II) I.S.1661

UPVC Door

Supplying and fixing of Un-plasticised Poly Vinyl Chloride (UPVC) Doors of FENESTA or equivalent using UPVC reinforced profiles 60mm/56mm x 56mm/63mm or equivalent for outer frames for two or more open able shutters 100mm/56mm x 60mm/84mm and thickness not less than 2.25mm for open able shutter frame capable of mounting single glazing system, the glazing bead profiles must be co-extruded with EPDM gasket and conform to the same test as profile, the gasket should be made of EPDM(Ethyl Propylene Di-Monomer) for better ceiling and noise reduction, the outer frame and shutter must have suitable drainage provision, structurally reinforced with hot dip galvanized up to 50 microns of minimum thickness of 1.2mm prefabricated & welded through fusion welding the Door sash shall be fitted with 6mm thick float glass toughened for Indian weather conditions of reputed make duly fixed with EPDM weathering seal resistant accessories for Door - friction stay hinges of stainless steel grade 304 - 2 nos., per sash, handle with alloy casting 1 no. per sash, multipoint locking system suitably concealed 1 no. per sash provided with raiser wedges for smooth operation and the system is to be installed at the site using anchor fasteners, silicon rubber, sealant, easy glazing / deglazing at site with 10 years manufactures warranty for discoloration, wrapping, mechanical failures, shrinkages, rotting, corrosion etc. with a quality certificate from relevant department of Govt. of India, including cost and conveyance of all materials, accessories, labour charges, transportation, erection at site with templates for casement sizing complete for finished item of work (structural requirements profiles are to be got approved by the Divisional Forest Officer-in-Charge of the work before fabrication of the shutter) as per specification and as per approval of the Divisional Forest Officer-in-Charge.

| | |
|---|---|
| fenesta/ncl/Duroplast Window (UPVC) | Supply and fixing of Un-plasticised Poly Vinyl Chloride (UPVC) sliding windows of fenesta/ncl/Duroplast - only two glass shutters sliding duly manufactured using UPVC reinforced profiles of 80mm x 52mm x 2.25mm or equivalent for outer frames, 54mm x 38mm x 2.25mm or equivalent for sliding shutter frames capable of mounting single glazing system, structurally reinforced with hot dip galvanized up to 50 microns of minimum thickness of 1.2mm prefabricated & welded through fusion welding the window sash shall be fitted with 5mm thick clear float glass (toughened) of reputed make duly fixed with EPDM weathering seal resistant accessories like clipping locking system made of aluminium 1 no., per set of sashes and the system is to be installed at the site using anchor fasteners, silicon rubber sealant, easy glazing / deglazing at site with 10 years manufactures warranty for discoloration, wrapping, mechanical failures, shrinkages, rotting, corrosion etc. with a quality certificate from relevant department of Govt. of India, including cost and conveyance of all materials, accessories, labour charges for transportation, erection at site with templates for casement sizing complete for finished item of work (structural requirements profiles are to be got approved by the Divisional Forest Officer-in-Charge of the work before fabrication of the shutter) as per specification and as per approval of the Divisional Forest Officer |
| Vitrified Fully Stain free | Supplying, fitting and fixing Vitrified (Fully) Stain free, Sandmist, Tropicana, Double charged Tile of make Carolina, Johnson, Somany or equivalent of colour White / Pink in floors of size 1000mm x 1000mm / 1200mm x 600mm having thickness not less than 12mm conforming to IS : 15622 -2006 laid on 20 mm thick cement mortar (1:4) and filling joints with white cement of approved quality including cost of all materials, labour T&P etc. required for the work all complete as per specification and as per approval of the Divisional Forest Officer-in-Charge |
| Germ Free Wall Tile | Providing, Fitting and Fixing of Germ free Wall Tile (size 600mm x 300mm) of Johnson or equivalent make in dados / skirting and risers of steps on 12mm thick cement plaster (1:3) jointed with neat cement slurry mixed with pigments to match the shade of the tiles including cost, carriage, cost of all labour etc. complete as per specification and as per approval of the Officer-in-Charge. |
| Ultra Eurocon Tile in Floor | Providing, Fixing of prepolished cement concrete tiles (floor) confirm to IS:1237:1980 (Reaffirmed in 1996) for heavy duty tiles (Exterior Grade) of 22-25mm thick of make Ultra Eurocon or Duracrete, Abrasion and wear resistant, as per parten, size and colour as specified or as approved by Officer-in-Charge to be used in floor laid over cement mortar (1:4) 20mm thick required neat cement jointing curing and cleaning complete. Item is based on product sample and specification of Ultra, Eurocon or Duracrete Tile as per specification and as per approval of the Divisional Forest Officer-in-Charge |
| Ultra Eurocon Tile in Dado | Providing, Fixing of prepolished cement concrete tiles (floor) confirm to IS:1237:1980 (Reaffirmed in 1996) for heavy duty tiles (Exterior Grade) of 22-25mm thick of make Ultra Eurocon or Duracrete, Abrasion and wear resistant, as per parten, size and colour or equivalent make in dados / skirting and risers of steps on 12mm thick cement plaster (1:3) jointed with neat cement slurry mixed with pigments to match the shade of the tiles including cost, carriage, cost of all labour etc. complete as per specification and as per approval of the Divisional Forest Officer-in- Charge |
| Structural Glazing / ACP Combination | Providing and Fixing of Structural Glazing approved make to be fabricated from roll formed sections made of pre-painted steel(base steel as per IS-513 of 0.6mm thick 'D' quality galvanized as per IS-277 with zinc of 120gm per sqm.) with primer of 5 - 75.7microns thick and finished paint with po-lyster paint (Black / Pearl white / Chocolate brown) of 12-16microns along with the alkydbacker at the back of 5-7 microns and the sizes of outer frame being 46 x 52mm and with all vertical & horizontal mullions are of 46 x 70mm and fixed beading are of 18 x 25mm. Sections for internal top and bottom frames in the louvered area should be 18 x 40mm. Top hung shutter should be 46x46mm. Accessories/ed beadings are of |

18x24 / gaskets are to be used as per the manufacturer's supply and specification like handle being made of high grade aluminum powder coated and with nylon receiver and gasket will be made of EPDM. All corner brackets are to be made of CRCA with zinc phosphating. The mullion caps and louvered-clips should be glass filled nylon. The sections are to be cut to length jointed and assembled by means of corner bracket and frames are fixed to the concrete / masonry walls by means of self expanding screws and glass to be used with safety laminated glass of 12.38 mm thick with 0.76 mm inter layer Poly Vinyl Butyral (PVB) lamination between two glass with outer being 6 mm thick toughened reflective of Reflectsol series of Saint Gobain & inner glass being of 6mm thick toughened clear of Saint Gobain make with all taxes.

Aluminum Composite Panel (ACP)

Providing and fixing of Aluminum composite panel of Alvcobond Durabuild or equivalent make coated with polyvinylidene fluoride (PVDF) resin cold coating on top and autocorrosive primer on the black aluminum panel with cost, conveyances, royalties, taxes of all materials and cost of all labour with T&P required for the work etc. complete as per specification & as per approval of the Officer

Gypsum Board

Providing & fixing Plain Gypsum board ceiling suspended from roof by adjustable G.I ceiling angle with spread at a distance not more than 600mm fixed to roof by Row plug & stiff cleat , Gypsum board 12.5mm thick held by G.I perimeter channel MF-3 & intermediate channel MF-7 framing, boarding, jointing & finishing with special type of gypsum compound etc including cost, conveyance & taxes of all materials, labour with T &P etc. complete in all respects as per approval of the Officer-in-Charge

Armstrong Ceiling

Providing false ceiling made out of Armstrong acoustical fine fissured RH-99 board NRC 0.55 sound attention 34 db fixed with frame made of G.I. perimeter channel runners (GYP steel make or equivalent boarded company) etc. and hanged from R.C.C. roof slab on 600mm x 600mm grid including cost, conveyance, taxes of all materials with cost of labour and T&P required for the work complete as per approval of the Employer.

Cornice for Gypsum Board

Providing fixing and fitting of cornice for gypsum board ceiling 4" wide of approved quality and approved make conferring to I.S with necessary bend etc. complete fixed to wall with screw etc as per the direction of E.I.C including cost of all material with taxes labour T&P etc. complete.

Expansion Joint

Roof Joint

Providing and fixing of expansion joint system of approved make and manufactures for various roof location as per approved drawings and direction of Officer-in-charge. The joints shall be of extruded aluminum base member with, self aligning and self centering arrangement support plates as per ASTM 6221-02. The system shall be such that it provides watertight roof to roof/roof to corner joint cover expansion control system that is capable of accommodating multidirectional seismic movement without stress of its components. System shall consist of metal profile that incorporates a universal aluminum base member designed to accommodate various project condition and roof treatments .The cover plate shall be designed of width and thickness required to satisfy movement and loading requirements and secured to base members by utilizing manufacturer's pre- engineered self-centering arrangement that freely rotates / move in all direction. The self centering arrangement shall exhibit circular sphere ends that lock and slide inside the corresponding aluminum extrusion cavity to allow freedom of movement and flexure in all directions including vertical displacement. The joint system shall resists damage or deterioration from the impact of falling ice, exposure to UV, Airborne contaminants and occasional foot traffic from maintenance personnel. Provision of moisture barrier Member in the joint system.

Wall Joint

Providing and fixing of wall joint (internal/external) location as per drawings and direction of Officer-in-charge. The joints shall be of extruded aluminium base members, self aligning / centering arrangement and support plates as per ASTM B221 - 02. The material shall be such that it provides an Expansion Joint System suitable for vertical wall to wall / wall ton corner application, both new and existing construction in office building & complex with no slipping down tendency among the components of the joint system. The joint system shall utilize light weight aluminum profiles exhibiting minimal exposed aluminium surfaces mechanically snap locking the multi cellular to facilitate movement.

Floor Joint

Providing and fixing of expansion joint system related with floor location as per drawing and direction of Officer. The joint system will be of extruded aluminum based members, self aligning / self centering arrangements and support plates etc. as per ASTM B221-02. The system shall be such that it provides floor to floor / floor to wall expansion control system for various vertical location in load application areas that accommodates multi directional seismic movement without stress to its components. System shall consist of metal profile with a universal aluminum base member designed to accommodate various project condition and finish floor treatments. The cover plate shall be designed of width thickness required to satisfy project movement and loading requirement and secured to base member by utilizing manufacturer' s pre- engineered self centering arrangements that freely rotates / moves in all direction. The self centering arrangement shall exhibits circular sphere ends that lock and slide in side the corresponding aluminum extrusion cavity to allow freedom of movement and flexure in all direction including vertical displacement. Provision of moisture barrier membrane in the joint system to have watertight joint is mandatory requirement all as per the manufactures design and as approved by Divisional Forest Officer. (Material shall confirm to ASTM 6063.

Anti Termite Treatment

Providing anti-termite treatment using approved quality of chemical emulsion, spraying the mixture uniformly by sprayer as pre-constructional anti termite **treatment and creating a chemical barrier under and around the column pits, wall trenches, top surface** treatment of of plinth filling, junction of walls & floors along

with external perimeter of the building, expansion joints, surrounding the pipes

and conduits etc. complete at the rate as directed by the manufacturer confirming to IS:6313 (Part-II) and as per direction of Divisional Forest Officer including cost of all materials, labour, taxes, sundries, T&P etc. complete. (The payments shall be made on the basis of actual plinth area of the building at Ground Floor & vertical faces will not be measured for payment.) Note:- *The Contractor shall have to furnish 10years Guarantee to maintain the anti-termite treated area / structures free from termite.*

Flush Door

Supplying, fitting and fixing Factory made 32mm thick B.W.P. I.S.I, marked flush door / window of Century / Mayur make or similar type with seven years guarantee against termite and borer etc. by using 25mm thick BWP ply with vinior laminated with two sides complete with wooden hinged cleats including cost of Stainless Steel fittings like Tower Bolt, Handel, Aldrop, Hinges, Screw etc., with conveyance and taxes of all materials complete in all respect as per approval of the Divisional Forest Officer.

Fixed Glazing with part top hung

Providing and fixing of Fixed Glazing with part Top hung of approved make to be fabricated from roll formed sections made of pre-painted steel (base steel as per IS-513 of 0.6 mm thick "D" quality, galvanized as per IS-277 with zinc of 120 Gm/Sq.mtr) with paint specification being with primer of 5-7 microns and finished paint with polyester paint (Black /Pearl white/ Chocolate Brown) of 12-16 microns along with the alkyd backer at the back of 5-7 microns and the sizes of outer frame being of 46x52 mm and with all vertical and horizontal mullions are of 46x70 mm and fixed beadings are of 18x25 mm. Top hung shutter should be of 46 x 46 mm. Accessories / gaskets are to be used as per the manufacturer's supply and specification like handle being made of high grade aluminum powder coated and with nylon receiver and gasket will be made of EPDM. All corner brackets are to be made of CRCA with zinc phosphating. The mullion caps and louvered-clips should be of glass filled nylon. The sections are to be cut to length, miter joined with corner bracket and frames are fixed to the concrete/masonry walls by means of self expanding screws and glass to be used of 5 mm reflective with all taxes complete.

| | |
|--|--|
| Ventilator | Providing and fixing of Fixed Ventilators of approved make to be fabricated from roll formed sections made of pre-painted steel (base steel as per IS-513 of 0.6 mm thick "D" quality, galvanized as per IS-277 with zinc of 120 Gm/Sq.mtr) with paint specification being with primer of 5-7 microns and finished paint with polyester paint (Black /Pearl white/ Chocolate Brown) of 12-16 microns along with the alkyd backer at the back of 5-7 microns and the sizes of outer frame being of 46x52 mm and with all vertical and horizontal mullions are of 46x70 mm and fixed beadings are of 18x25 mm. Accessories / gaskets are to be used as per the manufacturer's supply and specification like handle being made of high grade aluminum powder coated and with nylon receiver and gasket will be made of EPDM. All corner brackets are to be made of CRCA with zinc phosphating. The mullion caps and louvered-clips should be of glass filled nylon. The sections are to be cut to length, miter joined with corner bracket and frames are fixed to the concrete/masonry walls by means of self expanding screws and glass to be used of 5 mm reflective with cost, conveyance and taxes of all materials, cost of all labour, labour cess, T&P etc. complete as per approval of the Divisional Forest Officer.. |
| FRP Door Frame | Factory made FRP (alternately called GRP) Door Frame of size 75mmx100mm fabricated using E-glass Chopped Strand Mat (CSM) U.V stabilized Isophthalic Gel coat and impregnated with Isophthalic resin. The thickness of the GRP skins shall not be less than 2.00mm. The doorframe consists of four segments, which are provided with plug-in-socket arrangement in-situ in the mould. The segments are plugged in and are joined together by means of screw. The GRP frame shall be provided with wooden reinforcement on six locations for high screw holding capacity for fixing metallic hold fast and shall be consolidated by filling with medium density foam/plaster of paris with fibre reinforcement, Six numbers of 260mm x 25mm x 5mm size 'S' shaped M.S flat hold fast shall be provided with the frame. The material and process for manufacturing the doorframes shall conform to RV-TIFAC composites Design Centre's standards and specifications. The finish of door frame will be plain colour white/ Ivory/ Beige/ Light grey/ Golden brown/ Mahogany/ Teak wood/sand stone/ Champagne/ Pastel blue or any other colour using high quality pigments etc with cost, conveyance, taxes of all materials, cost of all labour, labour cess, T&P etc. required for the work complete in all respect as per specification and as per approval of the Officer-in- Charge |
| Swing Door | Providing and fixing of Swing Door of approved make to be fabricated from roll formed sections made of pre-painted steel (base steel as per IS-513 of 0.6 mm thick "D" quality, galvanized as per IS-277 with zinc of 120 Gm/Sq.mtr) with paint specification being with primer of 5-7 microns and finished paint with polyester paint (Black /Pearl white/ Chocolate Brown) of 12-16 microns along with the alkyd backer at the back of 5-7 microns and the sizes of outer frame being of 33 x 57 mm and shutter being of 46 x 52 mm and 46 x 46 mm and lock rail should be of 23 x 130mm. Accessories / gaskets are to be used as per the manufacturer's supply and specification like handle, lock and floor spring of approved quality. Gasket will be made of EPDM. All corner brackets are to be made of CRCA with zinc phosphating. The sections are to be cut to length ,mitre joined with corner bracket and frames are fixed to the concrete/masonry walls by means of self expanding screws and glass to be used of 6 mm clear with all taxes complete including cost of all materials all taxes labour, labour cess, T&P etc. complete as per approval of the Divisional Forest Officer |
| Anti Skid Vetrified Floor Tiles | Fixing of Anti skid Vetrified floor tiles of premium grade having thickness 8mm to 10mm confirming to IS 13756 of size 60cm x 60cm coloured / printed series in floors, Trades of steps & Landing over 20mm thick bed of cement mortar 1:4 jointed with cement slurry mixed with pigments to match the shade of the tiles, including rubbing & polishing etc. complete including cost, conveyance, taxes & royalties of all materials, labour with T&P complete in all respect. |
| Chequered Floor Tile | Fixing of Chequered tiles of premium grade having thickness 7mm to 8mm |

Ceramic Wall Tile

confirming to IS 13755 of size 30cm x 30cm special plain / printed series in floors over 20mm thick bed of cement mortar 1:4 jointed with cement slurry mixed with pigments to match the shade of the tiles, including rubbing & polishing etc. complete including cost, conveyance, taxes & royalties of all materials, labour with T&P complete in all respects as per approval of the Divisional Forest Officer. Fixing of Ceramic wall tiles of premium grade having thickness 6.5mm to 6.7mm confirming to IS 13753 of size 30cm x 20cm special plain / printed series in dados skirting & riser of steps on 12mm thick cement plaster 1:3 jointed with neat cement slurry mixed with pigments to match the shade of the tiles, including rubbing & polishing etc. complete including cost, conveyance, taxes & royalties of all materials, labour with T&P complete in all respects as per approval of the Divisional Forest Officer.

Floor, Wall & Roof FINISH of OTs

As per IPH standard.

STAINLESS STEEL RAILING

Fabricating, Supplying and Fixing in position Stainless steel Staircase Handrail of 1200mm high + (150~200) mm with Top hand rail of 50mm dia Hollow SS pipe of 16 gauge to be welded to 19mm wide 8mm thick brushed finish ss flat to shape and size as railing to the verticals made of 50x6 mm SS flats with 8mm spacer welded to SS brackets pipe which is connected with verticals 10mm dia SS pipe bent to profile and placed as per the detail architectural drawing and verticals are connected by 50mm wide 10mm thick brushed finish ss flat vertical supports to be grouted on to the slab. Verticals should be fixed to the concrete slabs with 75mm x 75mm, 10mm SS plate anchored with 4 Nos. of 10mm dia 75mm long SS brush finished Expansion bolts as per the detail drawings. The rate to include 10mm thick laminated glass panels in between the vertical steel pipes, the glass to be fixed for every 1200mm distance.

All SS sections shall be 304 grade with brush finish as per the project consultants and Site in charge approval.

The Contractor to submit the shop drawing of the same including the fabrication details, calculations and stability report

MS STAIRCASE RAILING (Wall)

Fabricating, Supplying and Fixing in position Staircase hand rail of 50mm dia hollow MS pipe of 16 gauge, fixed to 25mm dia MS pipe. bent to profile and welded to M.S insert plates of 100MM x 100MM, 6MM thick, anchored in the wall with 4 nos. of 10mm dia, 75mm long expansion bolts, etc., complete, as per architectural drawings. All MS sections to be finished with one coat of primer and 3 coat of synthetic enamel paint as per the detailed drawing

MS STAIRCASE RAILING (Slab)

Fabricating, Supplying and Fixing in position MS Staircase Handrail with Top hand rail of 50mm dia Hollow MS pipe of 16 gauge to be welded to the verticals made of 40mm dia MS tube (sealed with SS cap) with a connector 12mm dia MS rod bent to profile as per the detail architectural drawing. Balusters should be fixed to the concrete slabs with 60mm x 60mm, 8mm plate anchored with 4 Nos. of 8mm dia 75mm long Expansion bolts as per the detail drawings. The Mid-rails shall consist of 2 Nos 40X25mm MS square tube welded to balusters with a connector of 20mm MS square rod as per detailed drawings. 25mm wide, 6mm thk MS vertical are welded in bet the Mid-rails as per detailed drawings. All MS sections to be finished with Synthetic enamel paint.

SS RAMP RAILING

Fabricating, Supplying and Fixing in position Stainless Steel Disabled ramp railing of 1000mm high with Top hand rail of 50mm dia Hollow SS pipe of 16 gauge to be welded as railing to the verticals made of 50mm dia SS tubular sections as per the detail architectural drawing and 1 no 30 mm dia SS pipe as mid rails placed as per the detail Architectural drawings. Verticals should be fixed to the concrete slabs with 200mm x 150mm, 6mm thick SS plate anchored with 4 Nos. of 10mm dia 75mm long Expansion bolts with 70mm dia SS capping at the top as per the detail drawings. All SS sections to be of grade 304.

STAINLESS STEEL HANDRAIL WITHOUT GLASS

Fabricating, Supplying and fixing in position SS Staircase Handrail with Top hand rail of 50mm dia Hollow SS pipe of to be welded as railing connected to the verticals through 8mm connector plate with 2mm SS flat base plate below the hand rail. The Verticals shall be made of frame work of 2 Nos. 50X6 mm SS flat with 8mm spacer plate and rounded edges finish placed at 1000mm c/c as balusters as per the detail architectural drawing. Mid rails shall be 3 Nos 20mm dia SS rods connecting the verticals. Balusters should be fixed to the concrete slabs with 150mm x 100mm, 6mm SS plate anchored with 4 Nos. of 10mm dia 75mm long Expansion bolts as per the detail drawings. All sections to be of grade 304.

SS SINGLE PIPE RAIL

Fabricating, Supplying and Fixing in position SS single pipe wall rail of 50mm dia hollow SS pipe of 16 gauge, fixed to 12mm dia SS rod bent to profile and welded to insert plates of 100X100X 6mm thick, anchored in the wall with 4 nos. of 10mm dia, 75mm long expansion bolts, etc., complete, as per architectural drawings. All sections to be of grade 304.

PLYWOOD/ FLEXIBLE PLYWOOD:

Plywood of 4/6/9/12/19mm thick layered flat pressed teak wood bonded using only phenol formaldehyde synthetic resin confirming IS code 303. All plywood shall be of Boiling Waterproof type. All exposed plywood edged shall have PVC lipping. When decorative plywood is used for panelling, the same shall be of matching grains. All Plywood shall be treated for Termite, Borer proofing and painted with fire retardant paint.

PARTICLE/ MDF/ HDF BOARDS

Particle/ MDF/ HDF boards of 6 /9 /12 /18 /25 /32mm thick particle board of approved make confirming to E1 – Emission Class as European Standards BS EN 13986 or as American Standards ANSI

A208.2 – 1994 manufactured without using any formaldehyde resins or if not possible Phenol formaldehyde based resins shall be used with edges to have PVC lipping.

TIMBER –TEAK WOOD

The Teak wood should be of best quality available First quality teak wood in India. It should be well seasoned and free from gap, knots, wraps, cracks, and other defects. All woodwork shall be planed and neatly, truly finished to the exact dimensions. All joints shall be neat and strong, truly finished to the exact dimensions shown in the drawings. All joints shall be neat and strong, truly and accurately fitted and glued before being fitted together. All screws used in woodwork shall be of steel nettle fold make.

SALWOOD

The salwood used shall be Gumsal. It should be well seasoned and free from gap, knots, wraps, cracks, and other defects. All woodwork shall be planed and neatly truly finished to the exact dimensions. All joints shall be neat and strong, truly finished to the exact dimensions shown in the drawing. All joints shall be neat and strong and, truly and accurately fitted and glued before being fitted together. All screws used in the woodwork shall be of steel nettle fold make. All salwood sections shall be treated for Termite / Borer proofing.

DRAWER SLIDING CHANNELS:

The drawer channels being used shall be of telescopic type to the size as per the manufacturer's specifications adhering to detail drawings.

ALUMINIUM TUBE SECTIONS/ FRAMEWORK:

All aluminium work shall be CPWD specificaitons.

ADHESIVES:

The adhesives used shall be of approved make.

GLASS/ MIRROR:

The glass/ Mirror used shall be used as per approved make.

VENEER:

The veneer used shall be of 4.6mm thickness with minimum of 4mm thick BWP (Boiling Waterproof type) plywood backing of approved make.

LAMINATE SHEETS:

All laminate sheets will be of 1.5mm thick of approved make for all External Surfaces, 1.0mm for all internal surfaces and 0.8mm for Post formed tabletops

All hardware like Hinges, Screws, Locks, Door Closure, Floor Springs etc., shall be of approved make

BUILT IN-JOINERY

Where joinery work is specified to be built-in, it shall be the responsibility of the contractor to ensure that the joinery works are set in plumb and true in line and shall not be damaged or displaced by subsequent operations

All the exposed roof areas shall be provided with Thermal insulation.

All battery and UPS room shall be separated with fire wall

FURNITURE

All furniture shall be in accordance with the drawings and the sample piece as approved by Employer. The contractor shall first prepare a sample piece and the same shall be got approved by the Employer. The contractor will be expected to do all the modifications of the sample for which no claim will be entertained. Glue used shall be of superior synthetic quality such as Fevicol /Araldite

LIST OF APPROVED BRANDS AND/ OR MANUFACTURE OF MATERIALS.

| | |
|---|---|
| vitrified tiles | : Orient bell/ somany / kajaria / h & r Johnson/ euro |
| marble | : first quality imported type |
| water proofing compound | : roffe/ fosroc/ zypex /ardex/ percept |
| cement (white) | : jk white/ birla super white |
| cement (grey) | : acc/ birla super/ ultra-tech |
| concrete block | : apco or equivalent make |
| reinforcement steel | : TATA/SAIL /RINL/JINDAL |
| structural steel | : tata/ sail/ visl |
| ss railing | : lock it entp. / q railing |
| pvc spacers/ corner beadings / mesh | : arpitha exports/ boss |
| cement based polymer grout | : pidilite /laticrete/ bal endura |
| water repellent sealer chemicals | : pidilite / laticrete/ bal endura/ auqa mix |
| plywoods | : uniply/ sarda ply/ kitply / archid / green ply /century ply |
| mdf/ hdf – external grade (hmr) | : action tesa/asis/dura tuff/ nuwood |
| aluminium sections | : jindal/ bhoruka/ hindalco |
| modular aluminium partition/door sections | : jeb or approved equivalent |
| granite slabs (gang saw cut) | : first quality, water-cut type |
| stainless steel hinges | : lock wood/assa abloy/ dorma/ ir /geze/ hager/ hettich/ blum |
| locks | : dorma/ ir/ geze / hettich/ blum/ lock wood/assa abloy |
| door closures/ floor springs | : dorma/ sevax/ ir/ hager/ geze |
| lamine | : century laminating co ltd (merino)/ formica/ greenlam/ sundek century mica |
| flush doors | : kutty |
| upvc windows | : fenesta/ncl/Duroplast |
| vinyl flooring | : tarkett/gerflor/poyfloor |
| screws | : nettle fold (gkw)/patta make |
| etching, frosting film/ vinyl sheets / graphics | : 3m / avery |
| veneer | : uniply/ duro ply/ durian/ uro ply/ timex/ archid/ green/century plyboards (i) ltd |
| handles | : dorma/ d-line/ geze / blum/ hettich |

| | |
|--|---|
| glass / mirror | : saint gobain/ ashai |
| lacquered glass | : saint gobain / ashai |
| imported fabric | : milliken/ interface |
| indian fabric | : reliance/ vimal/ mayur |
| sound synth | : anutone make |
| paints | : berger / nerolac / asian/ j&n/skk/jotun |
| autocoat paint | : ici – duco/ asian/ berger |
| putty for all painting works | : rj london |
| texture paints | : zolatone/ oikos/ spectrum/ sk/ jotun |
| vinyl/ anti-static floor | : armstrong / gerflor/ tarkett |
| rubberised vinyl floor | : armstrong / gerflor / tarkett |
| linolieum floor | : forbo / armstrong/ tarkett |
| adhesives | : fevicol, jivanjor and araldite |
| wheel castors | : renolle / classis / nicholson |
| sliding channels | : blum/ hettich |
| powder coating paint/ vapour cure powder | : mrf/ marpol/ berger |
| 304/316 grade brush / stainless steel | : salem steel |
| grg, plain gypsum board, duraline suspension sym | : saint gobain gyproc india ltd |
| punning (gyp plaster) | : saint gobain gyproc india ltd) |
| gypsum board partition frame work, all related partition accessories & false ceiling suspension system | : saint gobain gyproc india ltd |
| recycled resin glass panel | : 3 form / lumicor |
| preprinted designer self adhesive vinyl film | : dinco form 3m |
| pvc spacers/ corner beadings | : arpitha exports/ catex specialities building |
| water based polyeruthane coat | :ica/asian/ aquvathane |
| ceramic tiles | :Orient bell/ somany / kajaria / h & r johnson/ euro |
| imported metal laminate | :sibu / homapal |
| stainless steel sink | :amc/ nirali/ diamond |
| interface trims | :cs group/ gradus |
| floor mats | :3m |
| ceramic writing board | :whitemark |
| slotted angle racks | :godrej / pan |
| compactors | :godrej |
| sound soak panels | :ecophone/armstrong/ usg / anutone |
| acoustic/fire sealant | : sevox/ hilti/3m/mccoy |
| glass manets fittings | : dorma/ ozone/ geze |
| self levelling compound | : roffee/ fosroc/ ardex from bal endura |
| wooden framed fire rated doors | : promat/ signum |
| steel fire doors | : signum/ shakti met/ mpp shredor (bangalore door tech) |

| | |
|---|---|
| digital printed vinyl | : 3m / avery |
| calcium silicate board, suspension sym | : hilux - ramco industries ltd /usg |
| imported acrylic solid surfaces | : du-pont corian |
| imported wall paper | : mayaramanoff / arte / muraspe durafort/ muraspec |
| modular false ceiling grids | : armstrong/usg/amf |
| anchor fasteners/pvc & metal plugs | : hilti/fischer |
| wooden flooring | : haro/ bona x/ pergo/ tarkett |
| curtain tracks | : walltracts, grorich horivert, hunter douglas |
| modular rubberized skirting | : mannington |
| modular false ceiling tiles | : armstrong/ usg/amf |
| ceiling suspension system | : armstrong/ donn/amf |
| modular false ceiling system accessories | : armstrong/ usg/amf |
| crash guards & corner guards | : rd plast / vishal ergonomics or equivalent |
| | |
| Chairs | : Godrej |

TECHNICAL SPECIFICATIONS OF P.H. PORTION OF WORK

(Internal & External PH Engg. Works)

1.1 : GENERAL INSTRUCTIONS: The detailed specifications given hereinafter are for the items of works described in the schedule of quantities attached herein, and shall be guidance for proper execution of work to the required standards. **It may also be noted that the specifications are of generalised nature and these shall be read in conjunction with the description of item in schedule of quantities and drawings.** The work also includes all minor details of construction which are obviously and fairly intended and which may not have been referred to in these documents but are essential for the entire completion in accordance with standard Engineering practice.

Unless specifically otherwise mentioned, all the applicable latest codes and standards published by the Indian Standard Institution and all other standards shall govern in all respects of design, workmanship, quality and properties of materials and methods of testing, method of measurements etc. Wherever any reference to any Indian Standard Specification occurs in the documents relating to this contract, the same shall be inclusive of all amendments issued there to or revisions thereof, if any. In case there is no I.S.I. specification for the particular work, such work shall be carried out in accordance with the instructions in all respects, and requirements of the Divisional Forest Officer. The work shall be carried out in a manner complying in all respects with the requirements of relevant bye-laws of the Municipal Committee/Municipal Corporation/Development Authority/Improvement Trust etc. under the jurisdiction of which the work is to be executed or as directed by the Divisional Forest Officer and, unless otherwise mentioned, nothing extra shall be paid on this account.

Samples of various materials, fittings etc. proposed to be incorporated in the work shall be submitted by the contractor for approval of the Divisional Forest Officer before order for bulk supply is placed.

The contractor shall take instructions from the Divisional Forest Officer regarding collection and stacking of materials in any place. No excavated earth or building materials shall be stacked on areas where other buildings, roads, services, compound walls etc. are to be constructed.

The contractor shall maintain in perfect condition all works executed till the completion of the entire work allotted to him. Where phased delivery is contemplated, this provision shall apply to each phase.

The contractor shall give a performance test of the entire installation(s) as per standard specifications before the work is finally accepted and nothing extra whatsoever shall be payable to the contractor for the test.

The contractor shall clear the site thoroughly of all debris, surplus excavated materials and rubbish etc. left out of his work and dress the site around the building to the satisfaction of the Divisional Forest Officer before the work is considered as complete.

The Divisional Forest Officer, Buildings shall be the sole deciding authority as to the meaning, interpretations and implications for various provisions of the specifications and his decision in writing shall be final and binding on all concerned.

In case any difference or discrepancy between the specifications and the description in the schedule of quantities, the schedule of quantities shall take precedence. In case of any difference or discrepancy between specifications and drawing, the specifications shall take precedence. In case any difference or discrepancy between the specifications for Civil works and specification for Public Health Engg. works, specifications for Civil works shall take precedence.

1.2 LIST OF INDIAN STANDARDS

The following IS codes shall be referred in execution of PH Engineering works.

| Indian Standard | Reaffirmation | Subject |
|------------------------------|------------------------|---|
| 27 - 1992 | Reaffirmed 2002 | Specifications for Pig Lead |
| 269- 1989 | Reaffirmed 2004 | Specifications for 33 grade Ordinary Portland Cement |
| 407- 1981 | Reaffirmed 2001 | Brass tubes for General purposes |
| 456- 2000 | -- | Code of practice for Plain & Reinforced concrete. |
| 458- 2003 | -- | Specifications for Concrete Pipes. |
| 554- 1999 | -- | Dimensions for pipe thread where pressure tight joints are required. |
| 636- 1988 | Reaffirmed 2003 | Fire fighting hose ,rubber lined or fabric reinforced rubber lined woven – jacketed |
| 638- 1979 | Reaffirmed 2003 | Sheet rubber jointing & rubber insertion jointing |
| 651- 1992 | Reaffirmed 2003 | Specifications for Salt glazed stoneware pipes & fittings. |
| 771 (Pt. I & VII) | | Glazed Fire Clay Sanitary Appliances. |
| 771- 1979 (Pt. I) | Reaffirmed 2003 | General requirements |
| 771- 1985 (Pt. II) | Reaffirmed 2003 | Specific requirements of kitchen & laboratory sinks |

| | | |
|----------------------------|------------------------|--|
| 771- 1979 (Pt. III/ Sec 1) | Reaffirmed 2003 | Specific requirements of urinals (section 1- Slab urinals) |
| 771- 1985 (Pt. III/ Sec2) | Reaffirmed 2000 | Specific requirements of urinals (section 2- Stall urinals) |
| 771- 1979(Pt. IV) | Reaffirmed 2003 | Specific requirements of postmortem slabs. |
| 771- 1979 (Pt. V) | Reaffirmed 2003 | Specific requirements of shower trays |
| 771- 1979 (Pt. VI) | Reaffirmed 2003 | Specific requirements of bed pan sinks |
| 771- 1981 (Pt. VII) | Reaffirmed 2003 | Specific requirements of slop sinks |
| 774- 1984 | Reaffirmed 2000 | Flushing cistern for water closet and urinals. |
| 775- 1970 | Reaffirmed 2000 | Cast iron brackets and supports for wash basin and sink. |
| 778- 1984 | Reaffirmed 2000 | Specifications for copper alloy gate & Globe check valves for water works |
| Indian Standard | Reaffirmation | Subject |
| 779- 1994 | Reaffirmed 2004 | Water meters (domestic type) |
| 781- 1984 | Reaffirmed 2001 | Specifications for cast copper alloy screw down bib taps & stop cocks for water services |
| 782- 1978 | Reaffirmed 2003 | Specification for Caulking lead. |
| 783- 1985 | Reaffirmed 2001 | Code of practice for laying concrete pipes. |
| 784- 2001 | Reaffirmed 2002 | Pre-stressed concrete pipes. |
| 884- 1985 | Reaffirmed 2000 | Fire aid hose reel for firefighting (for fixed installation) |
| 901 – 1988 | Reaffirmed 2003 | Specification for couplings, double males & double female, instantaneous pattern for Fire Fighting |
| 902 – 1992 | -- | Specification for suction hose couplings for Fire Fighting purposes. |
| 903 – 1993 | Reaffirmed 2003 | Couplings for fire hose delivery, branch pipe, nozzles specification |
| 904 – 1983 | Reaffirmed 2000 | Specification for 2 way and 3 way suction collecting heads for Fire Fighting purposes. |
| 905 - 1980 | Reaffirmed 2002 | Specification for delivery breechings, dividing and collecting instantaneous pattern for Fire Fighting |
| 906 – 1988 | Reaffirmed 2000 | Specification for revolving branch pipe for Fire Fighting |
| 907 – 1984 | Reaffirmed 2000 | Specification for suction strainer, cylindrical type for Fire Fighting purposes. |
| 908- 1975 | Reaffirmed 2000 | Fire Hydrants, Stand post type |
| 909- 1992 | Reaffirmed 2002 | Specifications for underground fire hydrants, sluice valve type |
| 940 – 1989 | -- | Portable Fire Extinguisher, water Type (Gas Cartridge) – Specification |
| 941- 1985 | Reaffirmed 2000 | Specification for Blower and Exhauster for Fire Fighting. |
| 1172- 1993 | Reaffirmed 2002 | Code of basic requirements for water supply, drainage and sanitation |
| 1200-1979 (Pt. 16) | Reaffirmed 2002 | Method of measurements for Laying of water and sewer lines including appurtenant items. |
| 1200-1981 (Pt. 19) | Reaffirmed 2002 | Method of measurements for Water supply, plumbing and drains. |
| 1239- 2004 (Pt I) | | Specifications for Mild steel tubes |
| 1239- 1992 (Pt. II) | Reaffirmed 2002 | Specifications for Mild steel Tubular & other wrought steel pipe fittings |
| 1300- 1994 | Reaffirmed 2000 | Phenolic moulding material specification |
| 1536- 2001 | -- | Specifications for Centrifugally cast iron (spun) pressure pipes for water, gas and sewage |
| 1537- 1976 | Reaffirmed 2000 | Specifications for Vertically cast iron pressure pipes for water, gas and sewage |
| 1538 -1993 | Reaffirmed 1999 | Cast iron fittings for pressure pipes for water, gas and sewage |
| 1700- 1973 | Reaffirmed 2003 | Drinking fountains |
| 1701- 1960 | Reaffirmed 2003 | Combination valve , mixing valves |
| 1703- 2000 | | Ball valve (horizontal plunger type) including floats for water supply. |
| 1711- 1984 | Reaffirmed 2000 | Self closing taps. |
| 1726- 1991 | Reaffirmed 2003 | Cast iron manhole covers and Frames. |
| 1729- 2002 | -- | Cast iron/ductile iron drainage pipes and fittings for over ground NP pipeline S/S series. |
| 1742- 1983 | Reaffirmed 2002 | Code of practice for building drainage |

| | | |
|---------------------------|------------------------|--|
| 1795- 1982 | Reaffirmed 2000 | Pillar taps for water supply purposes |
| 1978- 1982 | Reaffirmed 2002 | Specification for line pipe (M S Seamless) |
| 1979- 1985 | Reaffirmed 2002 | Specification for high test line pipe |
| 2065- 1983 | Reaffirmed 2001 | Code of practice for water supply in buildings. |
| 2097 – 1983 | Reaffirmed 2000 | Specification for foam making branch pipe. |
| 2104- 1981 | Reaffirmed 2003 | Water meter boxes (domestic type) |
| 2171 – 1999 | -- | Specification for portable fire extinguisher, dry powder (Cartridge Type) |
| 2190- 1992 | Reaffirmed 2002 | Code of practice for selection ,installation & maintenance of portable first-aid fire extinguishers |
| 2267- 1995 | Reaffirmed 2000 | Polystyrene moulding and extension materials – specification |
| 2326- 1987 | Reaffirmed 03 | Automatic flushing cistern for urinals |
| 2379- 1990 | Reaffirmed 2000 | Colour code for identification of pipe lines. |
| 2401- 1973 | Reaffirmed 2003 | Code of practice for selection, installation & maintenance of domestic water meters |
| 2470 (Pt. I to II) | -- | Code of practice for installation of septic tanks |
| 2470- 1985 (Pt.I) | Reaffirmed 2001 | Design criteria & construction |
| 2470- 1985 (Pt.II) | Reaffirmed 2001 | Secondary Treatment & disposal of septic tank effluent |
| 2527- 1984 | Reaffirmed 2000 | Code of practice for fixing rain water gutters and down pipes for roof drainage. |
| 2546 – 1974 | Reaffirmed 2000 | Specification for galvanized Mild Steel Fire bucket. |
| 2548- 1996(Pt. I) | Reaffirmed 2002 | Plastic water closet seats and covers. |
| 2548- 1996(Pt. II) | Reaffirmed 2002 | Plastic water closet seats and covers. |
| 2556 (Pt. 1 to XV) | -- | Specification for Vitreous (Vitreous China) sanitary appliances. |
| 2556-1994 (Pt.1) | Reaffirmed 2004 | General requirements |
| 2556-1994 (Pt.2) | Reaffirmed 1999 | Specific requirements of wash down water- closets |
| 2556- 2004 (Pt.3) | -- | Specific requirements of squatting pans |
| 2556- 2004 (Pt.3) | -- | Specific requirements of squatting pans |
| 2556- 2004 (Pt. 4) | -- | Specific requirements of wash basins |
| 2556- 1994 (Pt.5) | Reaffirmed 2004 | Specific requirements of laboratory sinks |
| 2556- 1995(Pt.6) | Reaffirmed 2003 | Specific requirements of urinals & partition plate |
| 2556- 1995 (Pt.7) | Reaffirmed 2003 | Specific requirements of accessories for sanitary appliances |
| 2556- 1995 (Pt.8) | Reaffirmed 1998 | Specific requirements of pedestal close coupled & wash down and siphonic water closets |
| 2556- 2004 (Pt.9) | -- | Specific requirements of pedestal type bidets |
| 2643 -1999 | -- | Type Threads where pressure tight joints are not mase on the threads – dimension, tolerances and designation |
| 2692- 1989 | Reaffirmed 2003 | Specification for Ferrules for water services. |
| 2871- 1983 | Reaffirmed 2000 | Specification for Branch pipe, universal, for firefighting purposes |
| 2878 – 2004 | -- | Fire Extinguisher, Carbon Dioxide Type (Portable and Trolley Mounted) –Specification. |
| 2951 (Pt. I to II) | -- | Recommendation for estimate of flow of liquids in closed conduits. |
| 2951- 1965 (Pt. I) | Reaffirmed 2003 | Head loss in straight pipes due to frictional resistance |
| 2951- 1965 (Pt. II) | Reaffirmed 2003 | Head loss in valves & fittings. |
| 3006- 1979 | Reaffirmed 2003 | Specification for Chemically resistant glazed S.W. pipes and Fitting |
| 3076- 1985 | Reaffirmed 2003 | Low density polyethylene pipes for potable water supply |
| 3114- 1994 | Reaffirmed 2004 | Code of practice for laying of Cast Iron pipes. |
| 3311- 1979 | Reaffirmed 2003 | Waste plug & its accessories for sinks & wash basins. |

| | | |
|----------------------------|------------------------|---|
| 3328- 1993 | Reaffirmed 2003 | Quality tolerances for water for swimming pools |
| 3389- 1994 | Reaffirmed 2000 | Urea formaldehyde moulding materials |
| 3486- 1966 | Reaffirmed 2000 | Specification for Cast iron spigot and socket drain pipes |
| 3489- 1985 | Reaffirmed 2000 | Specifications for enameled steel bath tubs |
| 3589- 2001 | -- | Specifications for steel pipes for water & sewage (168.3 to 2540 mm outside dia.) |
| 3597- 1998 | -- | Method of test for concrete pipes. |
| 3844- 1989 | Reaffirmed 2000 | Code of practice for installation and maintenance of internal fire hydrants Hose Reels in premises. |
| 3950- 1979 | Reaffirmed 03 | Specification for Surface boxes for sluice valve. |
| 3989- 1984 | Reaffirmed 2000 | Centrifugally cast (spun) iron spigot and socket soil, waste and ventilating pipes, fittings & accessories. |
| 4038- 1986 | Reaffirmed 2000 | Foot valves for water works purposes. |
| 4111 (Pt. I to V) | | Code of practice for ancillary structures in sewage system. |
| 4111- 1986 (Pt. I) | Reaffirmed 2001 | Manholes |
| 4111- 1985 (Pt. II) | Reaffirmed 2001 | Flushing tanks |
| 4111- 1985 (Pt. III) | Reaffirmed 2001 | Inverted siphon |
| 4111- 1968 (Pt. IV) | Reaffirmed 2001 | Pumping stations & pumping mains (rising mains) |
| 4111- 1993 (Pt. V) | Reaffirmed 2004 | Tidal out-falls |
| 4120- 1967 | Reaffirmed 2000 | Tubs and baths. |
| 4127- 1983 | Reaffirmed 2001 | Code of practice of laying of glazed stone ware pipes. |
| 4308 – 2003 | -- | Dry Chemical Powder for Fighting B & C class Fires– Specification. |
| 4350- 1967 | Reaffirmed 2001 | Specification for concrete porous pipes for under drainage. |
| 4733- 1972 | Reaffirmed 1992 | Methods of sampling & test for sewage effluents |
| 4736- 1986 | Reaffirmed 2001 | Specification for hot –dip zinc coating on mild stele tubes. |
| 4854 (Pt. I to III) | | Glossary terms for valves and their parts |
| 4854- 1969 (Pt. I) | Reaffirmed 1999 | Screw down stop, check & gate valves & their parts |
| 4854- 1968 (Pt. II) | Reaffirmed 1999 | Plug valves & cocks & their parts |
| 4854- 1974 (Pt. III) | Reaffirmed 1999 | Butterfly valves |
| 4927- 1992 | Reaffirmed 2002 | Unlined flax canvass hose for fire fighting |
| 4947 – 1985 | Reaffirmed 2000 | Specification for gas cartridge for use in Fire extinguishers. |
| 4984- 1995 | Reaffirmed 2002 | Specifications for HDPE pipes for water supply |
| 4985- 2000 | -- | Specifications for unplasticised PVC pipes for potable water supplies |
| 5290- 1993 | Reaffirmed 2003 | Specifications for Landing valves. |
| 5312 (Pt. I) | | Swing check type reflux (non return) valves |
| 5312- 1984 (Pt. I) | Reaffirmed 2000 | Reflux (non return) valves – single door pattern |
| 5329- 1983 | Reaffirmed 2001 | Code of Practice for sanitary pipe work above ground for building |
| 5330- 1984 | Reaffirmed 2000 | Criteria for design for anchor blocks for pen- stocks with expansions joints. |
| 5382- 1985 | Reaffirmed 2003 | Specifications for rubber sealing rings for water, gas & sewer mains |
| 5455- 1969 | Reaffirmed 2003 | Cast iron steps for manholes |
| 5600- 2002 | -- | Specifications for Sewage and drainage pumps |
| 5611- 1987 | Reaffirmed 2002 | Code of Practice for waste stabilization ponds (Facultative type) |
| 5714- 1981 | Reaffirmed 2002 | Specifications for Hydrant stand-pipe for firefighting |
| 5822- 1994 | Reaffirmed 2004 | Code of Practice for laying of welded steel pipes for water supply |
| 5961- 1970 | Reaffirmed 2003 | Specifications for Cast Iron grating for drainage purposes |

| | | |
|-----------------------------|------------------------|--|
| 6234-2003 | ----- | Portable fire Extinguisher water Type (Stored Pressure) – Specification |
| 6279- 1971 | Reaffirmed 2001 | Equipment for grit removal |
| 6280- 1971 | Reaffirmed 2001 | Sewage screens |
| 6295- 1986 | Reaffirmed 2001 | Code of practice for water supply & drainage in high altitude & / or sub-zero region |
| 6392- 1971 | Reaffirmed 1998 | Steel pipe flanges |
| 6411- 1985 | Reaffirmed 2000 | Specifications for gel coated glass fiber reinforced polyester resin bath tubs |
| 6418- 1971 | Reaffirmed 2000 | Cast Iron & malleable flanges for general engg. Purpose |
| 6494- 1988 | Reaffirmed 2000 | Code of Practice for water proofing of under ground water tanks & swimming pools |
| 6587- 1987 | Reaffirmed 2003 | Specifications for Spun hemp yarn |
| 7181- 1986 | Reaffirmed 2000 | Horizontally Cast Iron Double Flanged pipe for water, gas & sewage. |
| 7231- 1994 | Reaffirmed 2004 | Specifications for Plastic Flushing Cisterns for w.c. & urinals |
| 7558- 1974 | Reaffirmed 2001 | Code of Practice for domestic hot water installations |
| 7634 (Pt. I to III) | | Code of Practice for Plastic pipe work for potable water supplies |
| 7634- 1975 (Pt. I) | Reaffirmed 2002 | Choice of materials & general recommendations |
| 7634- 1975 (Pt. II) | Reaffirmed 2002 | Laying & jointing polyethylene (PE) pipes |
| 7634- 2003 (Pt. III) | -- | Laying & jointing unplasticised PVC pipes |
| 7740- 1985 | Reaffirmed 2001 | Code of Practice for road gullies |
| 7834 (Pt. I to VIII) | | Injection moulded PVC socket fittings with solvent cement joints for water supplies |
| 7834 – 1987(Pt.I) | Reaffirmed 2003 | General requirements |
| 7834- 1987 (Pt.II) | Reaffirmed 2003 | Specific requirements for 45 elbows 0 |
| 7834- 1987 (Pt. III) | Reaffirmed 2003 | Specific requirements for 90 elbows 0 |
| 7834- 1987 (Pt. IV) | Reaffirmed 2003 | Specific requirements for 90 tees 0 |
| 7834- 1987(Pt.V) | Reaffirmed 2003 | Specific requirements for 45 tees 0 |
| 7834- 1987 (Pt. VI) | Reaffirmed 2003 | Specific requirements for sockets |
| 7834- 1987(Pt. VII) | Reaffirmed 2003 | Specific requirements for unions |
| 7834- 1987 (Pt. VIII) | Reaffirmed 03 | Specific requirements for caps |
| 8008 (Pt. I to VII) | | Injection moulded HDPE fittings for potable water supplies |
| 8008- 2003 (Pt. I) | -- | General requirements for fittings |
| 8008- 1976 (Pt. II) | Reaffirmed 1997 | Specific requirements for 90 bends 0 |
| 8008- 2003 (Pt. III) | -- | Specific requirements for 90 tees 0 |
| 8008- 2003 (Pt. IV) | -- | Specific requirements for reducers |
| 8008- 2003 (Pt. V) | -- | Specific requirements for ferrule reducers |
| 8008- 2003 (Pt. VI) | -- | Specific requirements for pipe ends |
| 8008- 2003 (Pt. VII) | -- | Specific requirements for sandwich flanges |
| 8090 – 1976 | Reaffirmed 2000 | Coupling, branch pipe, nozzle used in hose reel tubing for fire fighting |
| 8329- 2000 | -- | Centrifugally cast (spun) ductile iron pressure pipes and fittings for water, gas & sewage |
| 8413 (Pt. I) | | Requirements for biological treatment equipment |
| 8413- 1977 (Pt. I) | Reaffirmed 2001 | Trickling Filter |
| 8718- 1978 | Reaffirmed 2000 | Specifications for vitreous enameled steel kitchen sinks |
| 8727- 1978 | Reaffirmed 2000 | Specifications for vitreous enameled steel wash basin |
| 8835- 1978 | Reaffirmed 1999 | Guideline for planning and design of surface drains. |

| | | |
|---------------------|------------------------|---|
| 8931- 1993 | Reaffirmed 2003 | Specifications for copper alloys Fancy single taps, combination tap assembly & stop valves for water services |
| 9140- 1996 | Reaffirmed 2002 | Method of sampling of vitreous & fire clay sanitary appliances |
| 9293- 1991 | Reaffirmed 1996 | Specifications for flax canvas |
| 9338- 1984 | Reaffirmed 2000 | Specifications for Cast Iron screw down stop valves and stop & check valves for water works purposes |
| 9668- 1990 | Reaffirmed 2000 | Code of practice for provision & maintenance of water supplies for Fire Fighting |
| 9739- 1981 | Reaffirmed 2003 | Specifications for Pressure reducing valves for Domestic water supply system. |
| 9758- 1981 | Reaffirmed 2003 | Flush valves and Fittings for water closets and urinals |
| 9762- 1994 | Reaffirmed 2004 | Specifications for polyethylene floats for float valves |
| 9763- 2000 | -- | Specifications for Plastic Bib taps, pillar taps, angle valves and stop valves for hot & cold water service. |
| 9972 – 2002 | -- | Specification for Automatic sprinkler Heads for Fire Protection Service. |
| 10221- 1982 | Reaffirmed 1997 | Code of practice for coating and wrapping of underground M.S. steel pipeline, |
| 11108 - 1984 | Reaffirmed 2000 | Specification for portable fire Extinguisher Halon 1211 Type. |
| 11606 – 1986 | Reaffirmed 2000 | Method for sampling of cast iron pipes and fittings. |
| 12183- 1987 (Pt. I) | Reaffirmed 2004 | Code of practice for Plumbing in multi- storied buildings (for water supply) |
| 12231 – 1987 | Reaffirmed 2003 | UPVC pipes for section & delivery lines of agricultural pumps– Specification. |
| 12235 – 1986 | Reaffirmed 1998 | Method of test for UPVC pipe for potable water supply |
| 12288 – 1987 | Reaffirmed 2002 | Code of practice for use and laying of Ductile Iron pipes |
| 12469 – 1988 | Reaffirmed 2002 | Specifications for pumps |
| 12592- 2002 | -- | Precast concrete frame & cover (SFRC frame & cover) |
| 12701-1996 | Reaffirmed 2002 | Specifications for rotational moulded polyethylene water storage tanks |
| 12709 - 1994 | Reaffirmed 2004 | Glassfiber reinforce plastic(GRP) pipes, joints & fittings for use for potable water supply – Specification. |
| 12820 – 1989 | Reaffirmed 1999 | Dimensional Requirements of Rubber Gaskets for Mechanical Joints & push in joints for use with Cast Iron Pipes & fittings for carrying water, Gas & sewerage. |
| 13095 – 1991 | Reaffirmed 2003 | Butterfly valves for general purposes |
| 13382-2004 | - | Cast Iron specials for mechanical & push-on flexible joints for pressure pipelines for water, gas & sewage |
| 13592- 1992 | Reaffirmed 2002 | Specifications for PVC soil, waste & rain water (SWR) including ventilation pipes |
| 13593 - 1992 | Reaffirmed 2002 | UPVC pipes fittings for use with section and delivery lines for Agricultural pumps – Specification. |
| 13916 – 1994 | Reaffirmed 2004 | Code of practice for installation of GRP piping system. |
| 13983-1994 | Reaffirmed 2004 | Specifications for stainless steel kitchen sinks & drain boards for domestic purpose |
| 14333-1996 | Reaffirmed 2001 | Specification for HDPE pipes for sewerage system. |
| 14402-1996 | Reaffirmed 2001 | GRP pipes, joints & fittings – Specification. |
| 14735-1999 | Reaffirmed 2004 | UPVC injection moulded fittings for UPVC – SWR pipes – Specifications. |
| 14845- 2000 | Reaffirmed 2004 | Resilient seated cast iron air relief valves for water works purposes – Spn |
| 14846- 2000 | -- | Specifications for sluice valve for water works purposes (50 to 1200 mm size) |

| | | |
|--------------|----|--|
| 15265 – 2003 | -- | Specifications for flexible PVC pipes or polymer reinforcement thermo plastic hoses for suction and delivery lines for Agricultural pumps. |
| 15328 – 2003 | -- | UPVC non pressure pipes for use in underground drainage and sewerage system – Specifications. |
| 15450- 2004 | -- | Polyethylene/Aluminium/Polyethylene composite pressure pipes for hot and cold water supplies – Specifications. |

1.3 MINIMUM WEIGHT OF MOST COMMONLY USED SANITARY APPLIANCES & WATER FITTINGS:

The minimum unit weight of each fitting shall not be less than as given in the following table and tolerance for weight shall be as per relevant IS code.

| S.N. | Description of items | Nominal size/ thickness | IS code | Minimum Unit Weight |
|------|--|-------------------------|-----------------------|---------------------|
| 1 | Brass non-fancy type Bib Tap Please see Table under relevant item for other sizes. | 15mm | 781- 1984 | 400 Grams |
| 2 | C.P. brass fancy type Bib Tap | 15mm | 8931- 1993 | 550 Grams |
| 3a | Brass non-fancy types Stop cock– Internally threaded | 15mm | 781- 1984 | 330 Grams |
| 3b | Brass non-fancy types Stop cock– Externally threaded | 15mm | 781- 1984 | 400 Grams |
| 4 | C.P. brass fancy types Stop cock | 15mm | 8931- 1993 | 550 Grams |
| 5 | C.P. brass concealed typed Stop cock | 15mm | 8931- 1993 | 750 Grams |
| 6 | C.P. brass fancy Pillar Tap | 15mm | 1795- 1982 | 650 Grams |
| 7 | C.P. brass waste coupling | 32mm | 3311- 1979 | 200 Grams |
| 8 | C.P. brass waste coupling | 40mm | 3311- 1979 | 250 Grams |
| 9 a | C.I. Nahani Trap 165mm inlet | 75mm (outlet) | 1729-2002 / 3989-1984 | 6.50 Kg. dia. |
| 9 b | C.I. Floor Trap 100 mm inlet dia. | 75mm (outlet) | 1729-2002 / 3989-1984 | 4.80 Kg. |
| 9 c | C.I. Nahani Trap with 20 mm water seal | 65mm (outlet) | non ISI | 4.50 Kg. |
| 10 | Cast Iron surface box for sluice valve (rectangular shape) | | 3950-1979 | 33 kg. |

The minimum unit weight of each fitting shall not be less than as given in the following table, which are used in General practice.

| S.N. | Description of items | Nominal size / thickness | Minimum Unit Weight |
|------|-------------------------------------|--------------------------|---------------------|
| 1 | C.P. brass fancy Shower rose | 15mm | 125 Grams |
| 2 | C.P. brass bottle trap | 32mm. | 500 Grams |
| 3 | C.P. brass bottle trap | 40mm | 550 Grams |
| 4 | C.P. brass Liquid soap dispenser | | 250 Grams |
| 5 | C.P. brass coat and hat hook | | 150 Grams |
| 6 | C.P. brass Towel rod bracket [pair] | | 100 Grams |
| 7 | C.P. brass Towel rod [600 mm long] | 20mm | 150 Grams |
| 8 | G.I. Clamps thickness for GI piping | 2 MM | |

| | | | |
|----|---|------|--------------|
| 9 | MS Clamps thickness for CI piping | 3 MM | |
| 10 | Rain water lead sheet flashing | | 38.00 kg/sqm |
| 11 | C.I. frame and cover for Gully Trap | | 7.50 kg. |
| 12 | S.S. grating for Nahani Trap | | 50 Grams |
| 13 | C.P. brass grating for Nahani Trap | | 190 Grams |
| 14 | C.P. Brass Dome shape grating | | 275 Grams |
| 15 | Cast Iron surface box for sluice valve (circular shape) | | 14 kg. |

1.4 MANDATORY TESTS / OPTIONAL TESTS :-

- The following mandatory tests shall be carried out when the qty. of materials to be incorporated in the work exceeds the minimum qty. specified in col.5 of the table below irrespective of whether the materials are with I.S. mark, or otherwise.
- Optional tests specified or any other tests shall be carried out in case of specialized work/ important structure at Department's discretion.
- Testing charges including incidental charge and cost of sample for testing shall be borne by the contractors for all mandatory tests.
- Testing charges for optional tests shall be paid by the Dept. However, the incidental charges and cost of sample for testing shall be borne by the contractor.
- In case of non-I.S. materials, it shall be the responsibility of the contractor to establish the conformity of material with relevant I.S. specification by carrying out necessary tests. Testing charges including incidental charge and cost of sample for testing shall be borne by the contractors for such tests.

1.4.1 Mandatory tests for P.H.E. works :

| Material | Test | Field/lab test | Test Procedure | Minimum quantity of material / work for carrying out the test 5 | Frequency of sampling | Remarks |
|---|--|---|--------------------------------------|---|--|---|
| 1 | 2 | 3 | 4 | 5 | 6 | 7 |
| GI pipes | <p>Physical</p> <p>Dimensional Nominal unit wt. Tensile, Elongation</p> <p>Chemical</p> <p>Mass of inc coating sulphur, phosphorus</p> | <p>Field/lab Field/lab Lab</p> <p>Lab Lab Lab</p> | <p>IS 4736 IS 228 IS 228</p> | <p>>20tubes >20tubes >100 / 500 upto 25 mm bore > 25 mm respectively.</p> <p>Up to bore 25mm tube / 1000 or part thereof > 25mm bore 1 tube / 500 tube</p> | <p>Sampling & criteria for conformit y as per 4711</p> | |
| C.I. pipes Water Quality "LA/A/B" class | <p>Dimensional unit weight hammer test Hydrostatic test Hardness & grade</p> | <p>Field/lab Field/lab Field/lab -----</p> | | <p>> 20 copies > 20 copies -----</p> | <p>Sampling & conformit y as per IS 1536 / 2001 IS1500</p> | <p>Hardness & grade shall be optional</p> |

| | | | | | | |
|--|--|---|---|---|---|--|
| C.I. pipes Soil Quality | Dimensional unit weight hammer test Hydrostatic test Hardness & grade | Field/lab Field/lab Field/lab Field/lab ----- | | > 20 copies > 20 copies ----- | Sampling & conformity as per IS 3981, IS 1729, IS 1500 | Hardness & grade shall be optional |
| Pig lead | Chemical Analysis | Lab | IS 1817 | Lot > 1000 Kg, if less Mfr. Test report to be furnished | Each lot > 1000 Kg. | |
| Store ware pipes | Hydraulic Test, Absorption Test, Test for Acid Resistance, Test for Alkali Resistance, Crushing strength Test For Alkali Resistance crushing strength test | Lab | IS 651 | 3 no. for lot of 150 5 no. for 151 to 1200 8 nos. for 1201 to 10000 | | |
| Cement Bricks | As per Civil specification | | | | | |
| Precast concrete man hole frame & covers / gratings | Dimension Load test | Lab | IS 12592 (Part I) | > 20 frame & covers / gratings | Sampling as per IS 12592 (Part-I) | |
| CI man hole frame & covers | Dimension Load test | Lab | IS 1726 | >50 frame & covers / gratings | Sampling as per IS 1726 | |
| Hume pipe NP class | Dimension Hydrostatic test Three- edge bearing Absorption test | Lab/field Lab Lab Lab | IS 458 IS 3597 IS 3597 IS 3597 | >50 pipes | As per IS 458 | |
| Sanitary fittings | Manufacture's Test certificate to be produced IS mark materials. | | | | | |
| CP brass fittings Bib taps / stop cocks | Manufacture's Test certificate to be produced IS mark materials. | | | | | |

3.0 SANITARY INSTALLATIONS

3.1 INDIAN WATER CLOSET

3.1.1 GENERAL : The item pertains for providing white or colour glazed vitreous chinaware Indian water closet of size and colour as specified in the schedule including fixing.

3.1.2 MATERIAL : Squatting Pan (Orissa Pattern) is of white or colour glazed vitreous China conforming IS 2556 Part III. Pan shall have flushing rim and are inlet of self draining type. It shall have weep hole at the following inlet to the Pan. The flushing inlet shall be in front unless otherwise specified.

The inside of the bottom of the pan shall have sufficient slope from the front to the outlet and surface shall be uniform and smooth to enable easy and quick disposal while flushing. The exterior surface of the outlet below the flange shall be an unglazed surface which shall have groove at right angle to the axis of the outlet. In all the cases pan shall have be provided with 100 mm Glazed Vitreous China `P` or `S` trap with 50 mm water seal and 40 mm size vent harm.

3.1.3 FIXING: The water closet pan shall be placed in position as shown in the drawing. The IWC shall be supported on brick masonry in CM 1:4 or as directed by the Divisional Forest Officer. The pan shall be fixed slightly lower than the floor level. If the pan or trap is damaged during handling of fixing, it shall be replaced by the contractor at his own cost. The pan, trap and C.I. pipe shall be jointed in 1:1 Cement Mortar with hemp yarn caulked. The gap between W.C. and floor shall be finished with white/matching cement as directed.

3.1.4 PROTECTION AND FINAL CLEANING: The IWC shall be covered with husk and sand till all the civil and electrical works are completed and shall be removed and cleaned on completion of civil and electrical works prior to testing and handing over. However, the contractor should ensure that the out let is plugged with gunny bags or similar materials to avoid the pipe getting blocked.

3.2 EUROPEAN/ ANGLO INDIA WATER CLOSET:

3.2.1 GENERAL : The item pertains for providing white or colour glazed vitreous chinaware European or Anglo Indian water closet with seat and cover of size and colour as specified in the schedule including fixing.

3.2.2 MATERIAL : European type water closet shall be wash down pattern unless otherwise specified. Water closet shall be vitreous china conforming to IS 2556 (Part-I & II). The closet shall be of one piece construction and shall have minimum two hole of 6.5 mm diameter for fixing closet to floor. Closet shall have an integral flushing rims of self draining type. Each water closet shall have an integral trap with either `S` or `P` outlet with and trap shall be uniform and smooth in order to enable an efficient flush. Plastic seat and cover shall be of black colour or as specified, they shall have conformity to IS2548 Part I & II.

3.2.3 FIXING : The water closet pan shall be placed in position as shown in the drawing. If the pan trap is damaged during handling or fixing, it shall be replaced by the contractor at his own cost. The pan, soil pipe shall be jointed in 1:1 Cement Mortar with hemp yarn caulked. The gap between W.C. and floor shall be finished with white/matching cement and sand as directed. Seat and cover shall be fixed to the Pan by two corrosion resistance hinge with 65 mm shank and threaded to within 25 mm from of flange. Seat shall be fixed in level by providing the washers of rubber with non ferrous or stainless steel washer to bolt.

3.3 WASH BASIN :

3.3.1 GENERAL The item pertains for providing colour or white glazed vitreous chinaware wash basin with or without pedestal of size and colour as specified in the schedule including fixing.

3.3.2 MATERIAL : . Wash basins shall be of vitreous china conforming to IS : 2556(Part-IV) of flat back or angle back as specified shall be of one piece construction including combined over flow, basin shall be provided with single or double tap holes of size 28 mm square or 30 mm rounded. Each basin shall have circular waste hole, or 5 sq.cm slot type over flow. Pedestals for wash basin shall be exactly same glazing that of basin. Pedestal shall be capable of supporting the basin and completely recessed at the back to accommodate supply and waste pipes and fittings. The basin shall be supported on pan of C.I cantilever brackets conforming to IS 775. Use of MS angle or Tee Section as bracket is not permitted.

3.3.3 FIXING The wash basin shall be fixed in position as indicated in the drawing. Basin shall be supported on a pair of C.I brackets which is embedded in cement concrete (1:2:4) block 100 x 75 x 150 mm. Oval shape or round shape wash basins are required to be fixed in RCC platform with stone tapping either fully sunk in stone top or flush with stone topping. The wall plaster on seat shall be cut to rest over the top edge of the basin so as not to leave any gap for water seepage through between wall plaster & skirting of basin. The gap between basin and wall shall be finished with white matching cement.

3.4 URINAL :

3.4.1 GENERAL : The item pertains for providing colour or white glazed vitreous chinaware urinal in single or range (1,2 & 3) and size as specified in the schedule with necessary fittings and appliances including fixing.

3.4.2 MATERIAL :

3.4.2.1 BOWL TYPE (WITH FLUSHING RIM) : Urinal basin shall be flat back or corner wall type lipped in front. The vitreous china conforming to IS 2556 (Part VI). Urinal shall have and integral flushing rim and inlet or supply horn for connecting flush pipe. Flushing rim and inlet shall be of the self draining type. At

bottom of basin and outlet horn for connecting outlet shall be provided. The inside surface of the urinal shall be uniform and smooth throughout to ensure efficient flushing.

3.4.2.2 BOWL TYPE FLAT BACK WITHOUT FLUSHING RIM : They shall be of vitreous china conforming to IS:2556 (Part-VI) constructed in one piece with providing slot or alternative fixing

arrangement at flat back and where the integral flushing rim is not provided, they shall be provided with ridges inside the bowl to divert towards the front line of the urinal.

3.4.2.3 STALL URINALS : The stall urinal and its screen shall be glazed fire clay conforming IS :771 (Part-III, Sec-2). The inside surface of stall and screen shall be regular and smooth throughout to ensure efficient flushing.

3.4.2.4 CP BRASS FLUSH PIPE : The flushing arrangement to urinals for single or in range shall be of CP brass with CP brass spreader of 15 mm dia conforming to IS : 407. The capacity of flush pipe for urinal in a range shall be as follows :

| Nos. of urinals in range | Capacity of flush tank | Size of C.P. brass Flush pipe | |
|--------------------------|------------------------|-------------------------------|--------------|
| | | Main | Distribution |
| One | 5 litres | 15mm | 15 mm |
| Two | 10 litres | 20 mm | 15 mm |
| Three | 10 litres | 25 mm | 15 mm |

3.4.3 FIXING :

3.4.3.1 BOWL TYPE FLAT BACK URINAL WITHOUT FLUSHING RIM (Single or Range): Urinal shall be fixed in position by using rawl plug, wooden plug, C.P screws etc. It shall be fixed at height of 65 cm from the standing level to the top of the lip of urinal or as directed by the Divisional Forest Officer. Each urinal shall be connected with 32 mm size waste pipe which shall discharge into channel or a floor trap.

3.4.3.2 STALL URINALS: The lip of the stall urinal shall be flush with the finished floor level. The stall urinal shall be laid over a fine sand cushion on average 25 mm thickness. The gap between wall surface, finished floor level and urinals shall not be more than 3mm and filled with water proofing plastic compound.

3.4.3.3 CP BRASS FLUSHING ARRANGEMENT: The flushing arrangement to urinal in single or range shall be of CP brass from 25 mm dia to 15 mm dia and CP brass spreader of 15 mm size to each urinal including the cost of CP brass elbows, tees, coupling, crosses, clamps, clips, union CP brass check nut and screws etc. CPbrass

3.5 URINAL SQUATTING PLATE:

3.5.1 Material: The squatting plates shall be of white vitreous china conforming to IS : 2556 (Part-I), IS : 2556 (Part-VI) with internal flushing rim with front or side inlet. Each squatting plat shall have integral longitudinal flush pipe. There shall be of 100 mm dia white glaze vitreous china channel with slope and outlet piece in front.

3.5.2 FIXING: The plate shall be fixed in position. The top edge of squatting plate shall be flush with the finished floor level adjacent to it. It shall be embedded on a layer of 25 mm thick cement mortar 1:6 laid over a bed of cement concrete 1:3:6. Gap between wall, floor etc. shall be finished with white/matching cement.

3.6 MARBLE/GRANITE PARTITION:

3.6.1 GENERAL : The item pertains for providing marble/granite partition of size and colour as specified in the schedule including fixing.

3.6.2 MATERIAL : The partition shall be of marble/granite slab of size & thickness as specified in the schedule. it shall be polished on both sides with exposed to proper shape the exposed edges of Marble/granite shall be made smooth corners rounded. Cracked or damaged marble/granite slab shall not be used in the work and shall be replaced if any by the contractor at his own cost and charges +/- 3mm tolerance shall be permissible for thickness of slab.

3.6.3 FIXING : Partition shall be fixed vertically in position as indicated in the drawing at proper height. 100 mm wide chases shall be cut in the wall and the partition shall embedded at least 50 mm in the wall using 1:2:4 cement concrete. After fixing the partition slab, the chases cut in the wall shall be made good to original condition.

3.7 DIVISION PLATE / PARTITION PLATE :

3.7.1 GENERAL : The item pertains for providing white or colour glazed vitreous chinaware division plate of size and colour as specified in the schedule including fixing.

3.7.2 MATERIAL : Division plate shall be white or colour glazed of size as specified in the schedule, and shall conform to IS .2556 PART VI.

3.7.3 FIXING : Division plate shall be fixed vertically in position at proper height with expandable anchor fasteners, CP brass screws, wooden plugs etc.

3.8 HALF ROUND CHANNEL :

3.8.1 GENERAL : The item pertains for providing colour or white glazed vitreous chinaware half round channel of size and colour as specified in the schedule including laying and fixing.

3.8.2 MATERIAL: The half round channel shall be of white or colour glazed vitreous chinaware of size as mentioned in the schedule with or without dead end and shall conform to IS 2556 part VII.

3.8.3 FIXING : The channel shall be laid to the correct alignment to required slope. It shall be fixed on 80 mm thick bed of 1:2:4 cement concrete. The channel shall be used in standard length. Pieces are not allow except where it is necessary to make up exact length. The joint and gap shall be finished with white / matching colour cement.

3.9 GLAZED FLOOR TRAP WITH DOME SHAPED GRATING :

3.9.1 GENERAL : The item pertains for providing white glazed vitreous chinaware floor trap with dome shaped C.P. Brass grating of size as specified in the schedule including fixing.

3.9.2 MATERIAL : The trap shape be of white vitreous chinaware of 100 mm dia. or as specified in the schedule with hinged type dome shaped grating of chromium plated brass or stainless steel as specified.

3.9.3 FIXING : The trap shall be laid to the correct alignment and to required slope. The trap shall be fixed on 80 mm thick bed or 1:2:4 cement concrete. The caulking shall be done using 1:1 cement concrete. The caulking shall be done using 1:1 cement mortar and hemp yarn.

3.10 TOILET PAPER ROLL HOLDER :

3.10.1 GENERAL : The item includes providing white or colour glazed vitreous chinaware toilet roll holder of size as mentioned in the schedule including fixing.

3.10.2 MATERIAL : The toilet paper roll holder shall be of CP brass or vitreous china on specified and of size and design as approved by the Divisional Forest Officer. Toilet paper roll holder shall conform as per IS standard and should have ISI mark.

3.10.3 FIXING : Toilet paper roll holder shall be fixed in position by means of C.P brass covers and rawl plug embedded in the wall. Vitreous china toilet paper roll holder shall fixed into the wall with 1:2 cement mortar. The pocket shall be cut in wall for toilet paper roll holder if not left finishing the gap with white/matching cement.

3.11 PVC WATER INLET CONNECTION:

3.11.1 GENERAL : The item pertains to providing colour or white PVC water inlet connection for cistern and wash basins.

3.11.2 MATERIAL : PVC water inlet connection shall conform to IS specifications and shall be of standard pattern with nylon insulation of minimum 450 mm long with CP brass check nut at both the end and shall be able to withstand the testing pressure of 1 MPa (10 kg/sq.cm.)

3.11.3 FIXING : The PVC water inlet connection shall be fixed in position as indicated in the drawing or as directed by the Divisional Forest Officer for flushing cistern and wash basins.

3.12 GLAZED FIRE-CLAY/ VITREOUS CHINA SINK:

3.12.1 GENERAL : Item includes providing white or colour glazed -fire clay sink for kitchen or vitreous china sink for lab as specified in the schedule of quantities including fixing.

3.12.2 MATERIAL : Laboratory sink shall be of vitreous china confirming to IS 2556 (PART-V) and kitchen sink shall be of glazed fire-clay conforming to IS 771 (Part-II) and shall have combined over flow of the weir type and invert shall be 30 mm below the top edge. These shall be of one piece construction and floor of sink shall gently slope towards the outlet. The outlet of sink should be suitable for waste fitting having flanges 88 mm diameter and waste hole of 65 mm diameter. the waster hole shall be either rebated

or beveled having the depth of 10 mm. C.I brackets for supporting sink shall confirm to IS: 775.

3.12.3 FIXING : The sink shall be supported on C.I cantilever brackets, embedded in cement concrete 1:2:4 block of size 100 x 75 x 150 mm. Bracket shall be fixed in the position before dado work is done. The height of front edge of sink from floor level shall be 80 cm or as directed by the Divisional Forest Officer. The gap between floor/wall and sink shall finish with white cement.

3.13 STAINLESS STEEL SINK :

3.13.1 GENERAL : Item includes providing the stainless steel sink with or without drain board of size as specified in the schedule including fixing.

3.13.2 MATERIAL The sink shall be manufactured from stainless steel of Salem or equivalent steel conforming to IS: 13983. Stainless steel sink shall be of one piece construction moulded out of 19 SWG (1mm) stainless steel sheet of grade AISI 304 (18/8) with stainless steel choke – stop strainer (waste coupling) checknuts conforming to IS 13983.

3.13.3 FIXING : The sink shall be fixed in position as indicated in the drawing. The sink shall be placed over the brackets or on the platform. Gap between sink and platform / wall shall be finished with white / matching cement.

3.14 SINK DRAIN BOARD :

3.14.1 GENERAL : The item includes providing white or colour glazed / fire clay drain board of size mentioned in the schedule fixing.

3.14.2 MATERIAL : The drain board shall be manufactured from stainless steel of Salem or equivalent steel conforming to IS: 13983. Stainless steel sink shall be of one piece construction and its thickness not less than 1 mm.

3.14.3 FIXING : The drain board shall be fixed in the position as indicated in the drawing. It shall be place over the brackets or on the platform. Gap between board and platform / wall shall be finished with white /matching cement.

3.15 SOAP DISH :

3.15.1 GENERAL : The item includes providing white or colour glazed chinaware type soap dish of size as mentioned in the schedule including fixing.

3.15.2 MATERIAL : Soap Dish shall be of CP brass or vitreous China on specified and of size, design an approved by the Divisional Forest Officer. Soap Dish shall conform to relevant IS standard and should have ISI certification mark.

3.15.3 FIXING : Soap Dish shall be fixed in position by means of C.P brass covers and rawl plug embedded in the wall. Vitreous china Soap Dish shall fixed into the wall with 1:2 cement mortar. The pocket shall be cut in wall, if not left, finishing the gap with white/matching cement.

3.16 GLASS MIRROR :

3.16.1 GENERAL : The item providing beveled or plain edges mirror with or without frame of size as mentioned in the schedule including fixing.

3.16.2 MATERIAL : The mirror shall be of superior sheet glass with edges rounded off or beveled, size 600 x 450 mm unless specified in the schedule. It shall be free from flaws, specks or bubbles and thickness plated and should not be less than 5.0 mm. The back of mirror shall be uniformly silver plated and should be free from silvering defects. Silvering shall now have a protective uniform covering of red lid paint, where beveled edge mirror are not available. Fancy looking mirrors with PVC beading/border or aluminum beading on stainless steel beading/border based on manufacturer's specification, provided nothing extra shall be paid on this account. The backing of mirror shall be provided with 6mm thick marine plywood or environmentally friendly material other than asbestos cement sheet.

3.16.3 FIXING : Mirror shall be fixed in position with 6mm thick marine ply wood backing. It shall be fixed by means of 4 nos. of CP brass screws & caps over rubber washers and rawl plug or as per the manufacturer's specification unless specified otherwise the longer side shall be fixed horizontally.

3.17 GLASS SHELF :

3.17.1 GENERAL : The item includes providing glass shelf of size as mentioned in the schedule including fixing.

3.17.2 MATERIAL : Glass shelf shall consist of an assembly of glass shelf frame of size 600 x 125 mm or as specified in the schedule. It shall be with a pair of CP Brass brackets fixed to the wall with CP screws and CP brass rails around with guard bar of 6 mm diameter fixed to the glass shelf frame with five numbers CP brass brackets. . The glass shall not be less than 5 mm thick. PVC stainless steel shelf or as per manufacturer`s specification and size as specified in the schedule of work shall be provided.

3.17.3 FIXING : The complete accessories shall be fixed to proper line and level as indicated in drawing with 40 mm long CP brass screws, wooden rawl plug, drilling hole and making good the wall to original condition after fixing the glass shelf.

3.18 LIQUID SOAP DISPENSER :

3.18.1 GENERAL: The item includes prdg. CP liquid soap dispenser of shape as mentioned in the schedule including fixing.

3.18.2 MATERIAL : Liquid Soap Dispenser shall be of C.P brass of heavy quality and from list of approved make.

3.18.3 FIXING : The liquid soap dispenser shall be fixed to proper height and level as indicated in drawing with 40 mm long CP brass screws, wooden rawl plug, drilling hole etc. and making good the wall to original condition after fixing.

3.19 TOWEL ROD/TOWEL RING:

3.19.1 GENERAL :The item includes providing Towel rod / towel ring of size as mentioned in the schedule including fixing.

3.19.2 MATERIAL : Towel rail shall be of C.P brass with two CP brass bracket coated with chromium plating of thickness not less than grade No.2 of IS 4827. The size of rail shall be 600 mm x 20 mm dia unless otherwise specified in the schedule. Towel ring of CP brass with one CP brass bracket with thickness not less than Grade No.2 of IS 4827. The diameter of the ring shall be 175 mm unless otherwise specified in the schedule. The diameter of ring rod shall not be less than 8 mm.

3.19.3 FIXING : The towel rod/ ring shall be fixed to proper line and level as indicated in drawing with CP brass screws, wooden raw plug, drilling hole etc. and making good the wall to original condition after fixing the towel rod.

3.20 SHOWER ROSE :

3.20.1 GENERAL : The item pertains to provide chromium plated brass shower rose of specified diameter with accessories including fixing.

3.20.2 MATERIAL : The shower rose shall be CP brass of approved and heavy quality. It's accessories shall conform to IS 1239 Part II.

3.20.3 FIXING : Shower rose shall be fixed to be water supply pipe line with necessary G.I fittings etc. as required by the Divisional Forest Officer. Jointing shall be done with the zinc, spun yarn etc. A few turns of fine hemp yarn dipped in linseed oil shall be taken over the threaded ends to obtain complete water tightness. Leaky joint shall be remade to make it leak proof at his risk & cost.

3.21 BIB TAP, STOP COCK & ANGLE STOP COCKS :

3.21.1 GENERAL : The item pertains to provide chromium plated brass bib tap and stop cock and angle stop cocks, free flanges (if joined to concealed pipe) including fixing

3.21.2 MATERIAL : Bib cock (Bib tap) is drawn off tap with a horizontal inlet and free out let and a stop cock is a valve with a suitable means of connections for insertion in a pipe line for controlling or stopping the flow. These shall be of size 15 mm size or as specified and shall be of screw down type. The closing device shall work by means of disc. carrying a renewable non-metallic washer with shuts against the water pressure on a seating right angles to the axis of the threaded spindle which operates it. The handle shall be crutch, butterfly or fancy design type securely fixed to the spindle. The tap shall open anti clock wise direction. Brass bib taps and stop cocks and angle stop cocks shall conform to IS 781, they shall be polished bright. The minimum finished weight of different sizes of bib tap weight of 15 mm size bib tap and stop cock shall be as per table given below. They shall be sound and free from taps, blow hole and fitting. Internal & External surface shall be clean, smooth and free from sand and neatly dressed. Taps shall be nickel chromium plated and thickness of coating shall not be less than service grade No.2 of IS 4827 and plating shall be capable of taking high polish which shall not be easily tarnished.

MINIMUM FINISHED MASS OF BIB TAPS AND STOP VALVES AS PER IS 781:1984 (Reaffirmed 2001)

| Size | Minimum Finished Mass | | | |
|----------|-----------------------|---------------------|---------------------|-----------|
| | bib taps | Stop Valves | | |
| | | Internally threaded | Externally threaded | Mixed end |
| 1 | 2 | 3 | 4 | 5 |
| Mm | Kg | Kg | Kg | Kg |
| 8 | 0.250 | 0.220 | 0.250 | 0.235 |
| 10 | 0.330 | 0.330 | 0.350 | 0.325 |
| 15 | 0.400 | 0.330 | 0.400 | 0.365 |
| 20 | 0.750 | 0.675 | 0.750 | 0.710 |
| 25 | 1.250 | 1.180 | 1.300 | 1.250 |
| 32 | - | 1.680 | 1.800 | 1.750 |
| 40 | - | 2.090 | 2.250 | 2.170 |
| 50 | - | 3.700 | 3.850 | 3.750 |

Every tap complete with its component shall with stand an internally applied hydraulic pressure of 2 MPa (20 kg/sq.cm) maintained for a period of 2 minutes during the period it shall neither leak nor sweat. Leaky joint shall be remade to make it leak proof without any extra cost from contractor.

3.21.04 FIXING : Bib tap stop cock shall be fixed to the pipe line with C.P. brass or G.I. specials, if required or as ordered by Divisional Forest Officer. Jointing shall be done with white zinc, spun yarn etc. A few turns of fine hemp yarn dipped in linseed oil shall be taken over the threaded ends to obtain complete water tightness.

3.22 COMBINATION TAP ASSEMBLY (WALL / PILLAR MOUNTED) :

3.22.1 GENERAL : The item pertains to provide chromium plated brass combination tap assembly, wall mounted hot & cold mixing for bath ,pillar mounted hot & cold mixing for sink ,basin, tub etc. including free flanges and fixing.

3.22.2 MATERIAL : The combination tap assembly shall be 15 mm nominal size or as specified in the schedule. It shall be of C.P. brass approved and heavy quality, and shall conform to I.S. 8931. Combination tap assembly shall be chromium plated-brass and shall conform to IS 8931. The nominal size of combination tap assembly shall be 15 mm nominal size or as specified. Casting of combination tap assembly shall be sound and free from laps, blow hole and pitting. External and internal surface shall be clean, smooth and free from sand and be neatly dressed. All the parts fitted to pillar tap shall be axial, parallel and cylindrical with surfaces smoothly finished. Thickness of C.P coating shall not be less than service grade no.2 of IS 4827 and plating should be capable of taking high polish which shall not easily tarnish or scale.

3.22.3 TESTING : Combination tap assembly shall withstand and internally applied hydraulic pressure of 1.6Mpa (16 kg/ sq.cm) for period of 1 minutes during which, it shall neither leak nor sweat. Leaky joint shall be remade to make it leak proof.

3.22.4 FIXING : Combination tap assembly shall be fixed to the pipe line as indicated in the drawing with necessary special as required or as ordered by Divisional Forest Officer. Jointing shall be done with white zinc, spun yarn etc. A few turns of fine hemp yarn dipped in linseed oil shall be taken over the threaded ends to obtain complete water tightness.

3.23 PILLAR TAP : (Non fancy & Fancy Type)

3.23.1 GENERAL : The item pertains to provide chromium plated brass pillar tap including fixing.

3.23.2 MATERIAL : The pillar tap shall be 15 mm nominal size or as specified in the schedule. Fancy type pillar tap shall be of C.P. brass approved quality and shall conform to I.S. 8931. Non fancy pillar tap shall be chromium plated-brass and shall conform to IS 1795. The nominal size of Pillar tap shall be 15 mm or as specified.

Casting of Pillar tap shall be sound and free from laps, blow hole and pitting. External and internal surface shall be clean, smooth and free from sand and be neatly dressed. All the parts fitted to pillar tap shall be axial, parallel and cylindrical with surfaces smoothly finished. The minimum of finish weight of Pillar tap shall not be less than 650 grams (body weight 250 gms, washer plate loose valve 150 gms and back nut 40 gms. Thickness of C.P coating shall not be less than service grade no.2 of IS 4827 and plating should be capable of taking high polish which shall not easily tarnish or scale.

3.23.3 TESTING: Pillar tap shall withstand and internally applied hydraulic pressure of 2 MPa (20 kg/sq.cm) for period of 2 minutes during which period, it shall neither leak nor sweat. Leaky joint shall be remade to make it leak proof without any extra cost from the contractor.

3.23.4 FIXING: Pillar tap shall be fixed to the pipe line as indicated in the drawing with necessary special as required or as ordered by Divisional Forest Officer. Jointing shall be done with white zinc, spun yarn etc. A few turns of fine hemp yarn dipped in linseed oil shall be taken over the threaded ends to obtain complete water tightness.

3.24 FLUSH VALVE :

3.24.1 GENERAL : The items pertains to provide chromium plated brass flush valve or brass concealed type flush valve with necessary accessories including fixing. (Free flanges if joined to concealed pipes)

3.24.2 MATERIAL : The Flush valve shall be nominal diameter as specified in the schedule of quantities. It shall be of C.P. brass approved and heavy quality, and shall conform to I.S. 9758. The flush valve shall have working pressure of 0.15 to 0.5 MPa. The valve shall be tested to a Hydraulic pressure of 2 MPa for 2 minutes.

3.24.3 FIXING : Flush valve shall be fixed to the pipe line as indicated in the drawing with necessary special as required or as ordered by Divisional Forest Officer. Jointing shall be done with white zinc, sun yarn etc. A few turns of fine hemp yarn dipped in linseed oil shall be taken over the threaded ends to obtain complete water tightness. Leaky joint shall be remade to make it leak proof.

3.25 BATH TUB (Enamelled steel sheet) :

3.25.1 GENERAL : Item includes providing sheet steel bath tub of size and without side panel as specified in the schedule of quantities including fixing or placing.

3.25.2 MATERIAL : The bath tub shall conform to IS 3489. The bath tub shall be constructed of the fewest practicable number of sections which shall be such as to ensure a suitable finished surface for the reception of the enamel coating. Any welded surface shall be adequately cleaned off inside and outside the bath tub. The necessary surface shall be free from undulations, drawing line and other defects deleterious to the provision of a satisfactory enamel coating.

The interiors of the bath tub shall be adequately and evenly coated with vitreous enamel. The enamelling shall conform to IS : 772. Thickness of the enamel shall not be less than 0.2 mm and not more than 0.5 mm, External surface of the bath tub shall be given one ground or primer enamel coating. Gloss, colour & opacity shall be uniform and visually satisfactory. The finish shall be free from crazing, dimples, rundown sagging tilters not more than two in number on the interior surface, pinholes not more than two in number for coloured bath tubs and not more than four for white enamelled bath tubs, specks shall be less than one mm in size and max. five in number and there shall be no grouping of pinholes and specks. Warpage of edges set against wall or floor and edges of roll rims shall not exceed 5 mm/m., warpage of all other edges shall not exceed 7.5 mm/m.

In forming the roll the outer edges shall be flanged or rolled back underneath sufficiently to prevent exposure of sharp edges. The vertical height of the flanged or rolled edges shall be not more than 30 mm. At the tap end of the roll, there shall be a level area within a radius of at least 25mm from the centre of each tap hole.

3.25.3 FIXING : The bath tubs shall be as flat bottomed as practicable. The fall (slope) long the bottom head end to outlet shall be adequate for complete emptying. The waste hole shall be so formed as to be suitable for receiving 40 mm waste fitting. The bath tubs shall be provided at the tap end, with effective means of attaching an earth continuity conductor. With each bath tub, two spacing washers of suitable thickness to take up the difference between the thickness of the metal of the bath tub and the depth of the seating on pillar taps shall be supplied. In addition, two fibre or lead washers for each tap shall be supplied for fitting above and below the tap roll to prevent the enamel from erasing when the taps are tightened in position.

3.26 BATH TUB : (Gel coated G.R.P. resin)

3.26.1 GENERAL : Item includes providing gel coated glass fibre reinforced polyester resin bath tub of size and with or without panel as specified in the schedule of quantities including fixing or placing.

3.26.2 MATERIAL : The bath tub shall conform to IS 6411. The fibre glass used in the manufacture of bath tubs shall be non alkaline conforming to 'E' type or 'A' type Grade. The proportion of the glass fibre shall not be less than 25% of the glass fibre reinforced polyester layer including gel coated layer. Unsaturated polyester resin used in the manufacture of bath tubs shall be resistant to not water and

weathering. When filler and colouring materials are used, their quality and proportion should be compatible to the polyester and the materials shall not have any harmful effect on the quality and performance of bath tubs. The bath tub shall possess a uniform gel-coat on the working surface. The resin used in the gel-coat shall be isophthalic grade of polyester or epoxy resin or any equally suitable chemical resistant grade of resin. The gel-coat shall not be less than 0.25 mm thickness nor more than 1.00 mm thickness.

In forming the roll, the outer edges shall be flanged or rolled back underneath sufficiently to prevent exposure of sharp edges. The vertical height of the flanged or rolled edges shall be not more than 30 mm. At the tap end of the roll, there shall be a level area within a radius of at least 25mm from the centre of each tap hole.

3.26.3 FIXING : The bath tub shall be one piece unit with an opening for waste outlet with floor sloping towards the outlet. An overflow shall normally be provided on the side near the waste outlet. An apron (side panel) may be provided, integrally or separately with the bath tub as specified in schedule of quantities. The waste opening shall be suitable for the proper installation of waste fittings which are ordinarily used for the purpose. The bath tub shall be provided with a supporting structure integral to the unit in between the space between the bottom of the bath tub and the floor of the building on which the bath tub rests unless otherwise specified. The materials of the supporting structure shall be at least equal to the material of the bath tub in resistance to deterioration with age and shall meet the requirement of fungus and vermin.

3.27 WASTE COUPLING :

3.27.1 GENERAL : The item pertains to provide chromium plated brass waste coupling including fixing.

3.27.2 MATERIAL : Waste Coupling shall conform to IS 3311. Waste fittings shall be of CP with thickness of CP coating not less than service Grade No.2 of IS 4827 which is capable of receiving polish and will not easily scale off. The fitting shall conform in all respect to IS 2963 and shall be sound, free from laps below, holes and fittings and other manufacturing defects. External and internal surface shall be clean and smooth. They shall be neatly dressed. The waste fitting for wash basin shall be of nominal size of 32 mm and for sink shall be nominal size 50 mm.

3.27.3 FIXING : Waste coupling shall be fixed to wash basin, sink or urinal as ordered with necessary specials. Jointing shall be done with white zinc, yarn etc. A few turns of fine hemp yarn dipped in the linseed oil shall be taken over the threaded ends to obtain complete water tightness. Leaky joint shall be remade to make it leakproof

3.28 BOTTLE TRAP :

3.28.1 GENERAL : The item pertains to provide chromium plated brass bottle trap including fixing.

3.28.2 MATERIAL : Bottle trap shall be of C.P with thickness of CP coating not less than service grade No. 2 of IS 4827 which is capable of receiving polish and will not easily scale off. The fitting shall conform in all respect of IS 2963 and shall be sound, free from laps below, holes and fittings and other manufacturing defects. External and internal surface shall be clean and smooth. They shall be neatly dressed and be truly machined so that nut smoothly moves on the body. The Bottle trap for wash basin shall be of nominal size of 32 mm and for sink shall be nominal size 50 mm.

3.28.3 FIXING : Bottle trap shall be fixed to wash basin, sink or urinal as indicated in the drawing with necessary specials or as ordered by the Divisional Forest Officer. Jointing shall be done with white zinc, spun yarn etc. A few turns of fine hemp yarn dipped in linseed oil shall be taken over the threaded ends to obtain complete water tightness. Leaky joint shall be remade to make it leak proof.

3.29 COAT AND HAT HOOK :

3.29.1 GENERAL : The item pertains to provide chromium plated brass coat and hat hook including fixing

3.29.2 MATERIAL : Coat & Hook shall be of three way type of approved and heavy quality. Coat & Hat Hook shall be CP brass and three way hook type or minimum six way patti type of 125 mm x 30 mm x 6mm size. CP coating shall not be less than service grade No.2 of IS 4827.

3.29.3 FIXING : The Coat and hat hook shall be fixed to proper line & level as indicated in drawing with CP brass screws.

3.30 FLUSHING CISTERN :

3.30.1 GENERAL : The item pertains to provide white or colour glazed chinaware / PVC / Cast Iron

flushing cistern with all inside syphonic fitting including fixing.

3.30.2 MATERIAL : The flushing cistern shall be automatic or manually of rates high level or low level as specified for water closets and urinals.

Cisterns shall be of cast iron, vitreous china, enamelled pressed steel conforming to IS 774 for Flushing Type and IS 2326 for Automatic flushing cistern and Plastic (IS 7231). Cistern shall be mosquito proof. All working parts shall be designed to operate smoothly and efficiently. the cistern shall have removable covers which shall fit closely on it and be screwed against top displacement where operating mechanism is attached to the cover. This may be made in two section, but the section supporting the mechanism shall be securely fitted or screwed to the body. The outlet fitting of the cistern shall be securely connected to the cistern. The nominal internal diameter of the cistern outlet shall not be less than 32 mm and 38 mm for high level and low level respectively. Length of outlet cistern shall be 37 +/- 2 mm. Ball valve shall be screwed type 15 mm in diameter and shall confirm of IS 1703. The flat shall be made of polyethylene as specified in IS 9762. A high level cistern is intended to operate with minimum height of 125 cm and a low level cistern with maximum height of 30 cm between the top of the pan and under side of the cistern. A G.I chain strong enough to sustain a sudden applied pull of 10 kg or a dead load of 50 kg without any apparent or permanent deformation of the chain rings shall be attached to the ring or hook of the level manually operated high level C.I cistern. In case of low level cistern handle shall be of CP brass. In case of Plastic cistern, operation of cistern shall be through Push Button at the top for dual system and beyond plastic handle.

The discharge rate of the cistern as per IS 774 shall be 10 +/- .5 litres 6 second and 5 +/- .5 litres in 3 second for cistern capacity 10 ltrs. and 5 ltrs. respectively. Flush pipe shall be of class `B` G.I pipe of 32 +/- mm diameter for high level. Polyethylene flush pipe shall be low density confirming to IS 3076 or high density confirming to IS 4984 or UPVC pipe confirming to IS 4965 of 40 mm outer diameter.

Over flow pipe shall not be less than +/- 5mm `B` diameter. It shall be of G.I valve with mosquito proof jalli of 1.25 mm dia.

3.30.3 FIXING: The chinaware flushing cistern shall be placed over a pair of C.I. brackets. C.P. brass flush pipe shall be fixed to cistern and W.C. pan using check nut, spun yarn, cement mortar etc.

The cast iron flushing cistern shall be placed over a pair of C.I. or G.I. or PVC flush pipe of specified diameter shall be fixed to cistern and W.C. pan by using check nut, white zinc, spun yarn, cement mortar etc.

The PVC flushing cistern shall be placed or fixed as recommended by the manufacturer, PVC flush pipe of specified diameter shall be fixed to cistern and W.C. pan by using check nut, white zinc, spun yarn, cement mortar etc.

3.31 BRACKET :

3.31.1 GENERAL : The item pertains to provide a pair of bracket for wash basin, sink, Flushing, cistern etc. including fixing.

3.31.2 GENERAL : The item pertains to provide a pair of bracket for wash basin, sink, cistern etc, including fixing.

3.31.3 FIXING : Brackets shall be embedded into or fixed to the wall with plugs, screws, nails etc. Hole shall be made in the wall, if they are not left for fixing the brackets and shall be made good after fixing. The gap shall be filled with 1:2 cement mortar and finishing shall be done with white / matching colour cement.

4.0 : WATER SUPPLY SYSTEM:

4.1 G.I. PIPING WORK (Exposed):

4.1.1 GENERAL : The item includes provision of G.I. pipes with G.I. fitting of specified nom. bore and class as mentioned in the schedule including laying, fixing. The G.I. pipes and fittings shall run on the surface of the walls or ceilings unless otherwise specified.

4.1.2 MATERIAL : The pipes and fittings shall be of M.S. galvanised as specified in the schedule. They shall conform to IS 1239 (P-I). All the pipes and fitting shall have ISI certification mark. The specified nominal bore of the pipe shall refer to inside approximate bore according to the thickness corresponding to outside fixed diameter. The pipe and fittings shall be smooth, sound, free from any imperfections and neatly dressed. The pipe and fitting shall be able to withstand a hydrostatic test pressure of 5 MPa (50 Kg/cm²) maintained for at least 3 seconds at manufacturing works (lab test). The table showing the dimensions and different bores of pipes are given below.

WEIGHT OF GALVANISED & BLACK (BOTH) M.S. TUBES FOR ORDINARY USES IN WATER

A) CONFORMING TO IS: 1239 (PART-1) 2004

| Nominal Bore | Class | Outside Diameter | | Wall thickness in mm | Nominal Weight (Kg/M) | |
|--------------|-------|------------------|---------|----------------------|-----------------------|--------------------|
| | | Maximum. | Minimum | | Plain Ended | Screwed & Socketed |
| | | Mm | Mm | | | |
| 15 | L | 21.4 | 21.0 | 2.0 | 0.947 | 0.956 |
| | M | 21.8 | 21.0 | 2.6 | 1.21 | 1.22 |
| | H | 21.8 | 21.0 | 3.2 | 1.44 | 1.45 |
| 20 | L | 26.9 | 26.4 | 2.3 | 1.38 | 1.39 |
| | M | 27.3 | 26.5 | 2.6 | 1.56 | 1.57 |
| | H | 27.3 | 26.5 | 3.2 | 1.87 | 1.88 |
| 25 | L | 33.8 | 33.2 | 2.6 | 1.98 | 2.00 |
| | M | 34.2 | 33.3 | 3.2 | 2.41 | 2.43 |
| | H | 34.2 | 33.3 | 4.0 | 2.93 | 2.95 |
| 32 | L | 42.5 | 41.9 | 2.6 | 2.23 | 3.27 |
| | M | 42.9 | 42.0 | 3.2 | 3.10 | 3.13 |
| | H | 42.9 | 42.0 | 4.0 | 3.79 | 3.82 |
| 40 | L | 48.4 | 47.8 | 2.9 | 3.23 | 3.27 |
| | M | 48.8 | 47.9 | 3.2 | 3.56 | 3.60 |
| | H | 48.8 | 47.9 | 4.0 | 4.37 | 4.41 |
| 50 | L | 60.2 | 59.6 | 2.9 | 4.08 | 4.15 |
| | M | 60.8 | 59.7 | 3.6 | 5.03 | 5.10 |
| | H | 60.8 | 59.7 | 4.5 | 6.19 | 6.26 |
| 65 | L | 76.0 | 75.2 | 3.2 | 5.71 | 5.83 |
| | M | 76.6 | 75.3 | 3.6 | 6.42 | 6.54 |
| | H | 76.6 | 75.3 | 4.5 | 7.93 | 8.05 |
| 80 | L | 88.7 | 87.9 | 3.2 | 6.72 | 6.89 |
| | M | 89.5 | 88.0 | 4.0 | 8.36 | 8.53 |
| | H | 89.5 | 88.0 | 4.8 | 9.90 | 10.10 |
| 100 | L | 113.9 | 113.0 | 3.6 | 9.75 | 10.00 |
| | M | 115.0 | 113.1 | 4.5 | 12.20 | 12.50 |
| | H | 115.0 | 113.1 | 5.4 | 14.50 | 14.80 |
| 125 | M | 140.8 | 138.5 | 4.8 | 15.90 | 16.40 |
| | H | 140.8 | 138.5 | 5.4 | 17.90 | 18.40 |
| 150 | M | 166.5 | 163.9 | 4.8 | 18.90 | 19.50 |
| | H | 166.5 | 163.9 | 5.4 | 21.30 | 21.90 |

| Mark | Class | Colour Code | TOLERANCES | | | | | |
|---|----------------|-------------|-------------|---|-----------------|-------|-------------------|------|
| | | | THICKNESS | | WEIGHT | | | |
| | | | | | For Single Tube | | For 10 tones load | |
| | | | (+) | (-) | (+) | (-) | (+) | (-) |
| L | “Light” class | Yellow Band | Not limited | 8.0% | 10.0% | 8.0% | 7.5% | 5.0% |
| M | “Medium” class | Blue Band | Not limited | 10.0% | 10.0% | 10.0% | 7.5% | 7.5% |
| H | “Heavy” class | Red Band | Not limited | 10.0% | 10.0% | 10.0% | 7.5% | 7.5% |
| Random length of tube:- unless otherwise specified 4.0 to 7.0 m includes one socket for screwed & socketed tubes | | | | COATING:- Zinc coating as per IS 4736 (latest revision) | | | | |

4.1.3 LAYING : The plumbing contractor shall set the layout of the plumbing approved by the

Divisional Forest Officer as may be required by the bye-laws. Pipes shall be laid in plumb and in straight and parallel lines. When unavoidable, pipes may be buried for short distances provided additional protection is given against damage and where so required joints are not buried. Where directed by the Divisional Forest Officer –in- charge, A M.S. tube sleeve shall be fixed at a place the pipe is passing through a wall or floor for reception of the pipe and to allow freedom for expansion ,contraction and other movements. In case the pipe is embedded in walls or floors the pipes shall be painted with anticorrosive bitumastic paints of approved quality. The pipe shall not come in contact with mortar or lime concrete as the pipe is affected by lime. Under the floors the pipe shall be laid in layer of sand filling as done under concrete floors.

4.1.4 FIXING : The entire pipe line shall be fixed in position as shown in the drawing or as directed by the Divisional Forest Officer. All pipes shall be fixed truly vertical and horizontal unless unavoidable. The pipe line shall be supported with “U” type G.I. clamps not less than 2 mm thick and G.I. nails not less than 40 mm long, wooden gutties etc keeping the pipe about 15 mm clear of the wall .

Spacing between clamps for fixing internal piping shall be as per IS 2065 – 1983 as given below :

| Nom. bore of pipe | For Horizontal Runs | For Vertical Runs |
|-------------------|---------------------|-------------------|
| 15mm | 2.0 M | 2.5 M |
| 20 mm to 32 mm | 2.5 M | 3.0 M |
| 40 mm to 50 mm | 3.0 M | 3.5 M |
| 65 mm to 80 mm | 3.5 M | 5.0 M |

No joints shall be located inside the wall. If the pipe is required to be cut and the end threaded, the ends of the cut end shall be filed smooth and any obstruction in bore shall be entirely eliminated, dwntake line shall be provided with union of every floor for easy maintenance. This shall be made of line threaded pipe ends and coupler with checknut to avoid leakage. Die cast union shall not be permitted in the shaft.

4.1.5 JOINTING : While fixing the pipe line the joints shall be made by applying a few turns of hemp yarn dipped in linseed oil shall be taken over the threaded end of the pipe and socket screwed home using the pipe wrench, pipe connected shall touch each other and the socket covering each end about equally. The branch connection shall not protrude in the bore of parent pipe.

4.1.6 PAINTING : G.I. pipes and fittings running exposed shall be painted with two coats of oil paint of approved make and shade over a coat of approved primer.

4.1.7 TESTING : The pipes and fittings after they are laid and jointed shall be tested to hydraulic pressure of 1 MPa (10 Kg/sq.cm). The pipes shall be slowly and carefully charged with water allowing all air to escape and avoiding all shock or water hammer. The draw off taps and stop cocks shall then be closed and specified hydraulic pressure shall be applied gradually, Pressure gauge must be accurate and preferably should have been recalibrated before the test. The test pump having been stopped, the test pressure should be maintained without loss for at least 2 (two) hours. The pipes and fittings shall be tested in sections as the work of paying proceeds, having the joints exposed for inspection during the testing. Pipes or fittings which are found leaking shall be replaced and joints found leaking shall be redone, without extra payment.

4.2 G.I. PIPING WORK (Concealed) :

4.2.1 GENERAL : The item includes provision of G.I. pipes with concealed type fittings of specified nom. bore and class mentioned in the schedule including laying, fixing, wrapping with hessian cloth, painting and testing.

4.2.2 MATERIAL : Please refer clause 4.1.02

4.2.3 CHASES : Chases of size 75 mm x 75 mm shall be cut in the wall, floor, slab wherever required or as directed by chases cutting machine. After testing the pipe line the chases shall be filled with cement mortar 1:3 and surface made good to its original condition.

4.2.4 LAYING : : The plumbing contractor shall set the layout of the plumbing approved by the Divisional Forest Officer as may be required by the bye-laws. Pipes shall be laid in plumb and in straight and parallel lines. No lime plaster or composition containing lime shall be allowed to come in direct contact with the pipe, which are to be concealed as the pipe is affected by lime.

4.2.5 FIXING : The entire pipe line shall be fixed in position as shown in the drawing or as directed by the Divisional Forest Officer. All pipes and fittings, which are to be concealed, shall be properly embedded in the wall, flooring etc. after being treated. No moulding or plaster design or any ornamental plaster work shall be done over the walls or flooring or ceiling where concealed pipes have been laid.

If the pipe is required to be cut and the end threaded, the burns of the cut end shall be filed smooth and any obstruction in bore shall be entirely eliminated.

4.2.6 JOINTING : Please refer Clause No. 4.1.05

4.2.7 PAINTING : All the concealed piping work shall be thoroughly painted with two coats of anti-corrosive black bitumastic paint of approved quality shade over a coat of approved primer before concealing and filling the mortar.

4.2.8 INSULATION : The hot water pipe line concealed on the wall, floor etc. after painting shall be insulated with 2.5 mm thick 95% asbestos magnesia compound of approved make all round the pipe and fittings.

4.2.9 WRAPPING : After painting the cold water pipe line, it shall be wrapped with two layers of hessian cloth of approved quality.

4.2.10 TESTING : Please refer clause No.4.1.07

4.3 UNDER GROUND G.I. PIPING WORK :

4.3.1 GENERAL : The item includes supplying G.I. pipes and fittings of specified nom. bore and class as mentioned in the schedule including laying, jointing and painting.

4.3.2 MATERIAL : Please refer clause 4.1.02

4.3.3 TRENCHES : The galvanised iron pipes and fittings are to be laid in trenches. The widths and depths of the trenches for different diameter of the pipes shall be as given below :

| Diameter of pipe (mm) | Min. Width of trench (mm) | Min. Depth of trench (mm) |
|------------------------------|----------------------------------|----------------------------------|
| 15 to 50 | 300 | 600 |
| 65 to 100 | 450 | 750 |

When excavation is done in rock, it shall be cut deep enough to permit the pipes to be laid on a cushion of sand of min. 7.5 cm. At joints the trench width shall be widened where necessary. The work of excavation and refilling shall be done true to line and gradient in accordance with general specifications for earth work in trenches as per clause 2.0.

4.3.4 LAYING : Where a pipe is to be laid under ground, the particular length of pipe should be protected by first painting before laying and then wrapping around the pipe a layer of jute or hessian cloth in the form of bandage, so that this cloth in the form of bandage, stick to the composition which has been freshly applied.

The pipe shall be laid into the trench and screwed with sockets, elbows, tees, bends etc. as necessary. The pipe line laid near electric train lines, power transmission lines, electric railway, power houses etc. should be provided with insulating joints at frequent intervals to guard against electrolysis.

Pipes shall be so laid as not to expose to sun or be subjected to any injury or risk to the pipe. As far as possible pipes shall be laid in straight and parallel lines. They shall be used in standard length pipe pieces being used only where necessary to make up the exact length.

4.3.5 JOINTING : Please refer clause No. 4.1.05

4.3.6 DEWATERING : The contract rate shall include bailing or pumping out all the water if accumulated during the progress of the work either from rain, seepage, springs or any other cause.

4.3.7 TESTING : Same as clause 4.1.07

4.3.8 PAINTING : G.I. pipes and fittings shall be painted with two coat of anticorrosive paint before pipe line is laid and wrapping the pipe and fitting with jute or hessian cloth in the form of bandage.

4.4 HIGH DENSITY POLYETHYLENE PIPING WORK FOR WATER SUPPLY :

4.4.1 GENERAL : The item includes supplying of HDPE pipes with fittings of specified diameter including laying, fixing, cutting, jointing.

4.4.2 MATERIAL : The pipes and fittings shall conform to series IV of IS 4984. HDPE pipes and fittings shall be free from cracks, flaws and defects and shall be able to withstand a pressure as mentioned in the schedule.

4.4.3 EXAMIN IN G : Before laying the pipe line, it shall be first examined for damages and cracks, No cracked or damaged pipe and fittings shall be used in the work and they shall be removed from the site by the contractor at his own cost and charge.

4.4.4 LAYING : The pipes shall be carefully laid straight to the correct alignment in gradients as indicated in the drawing. All the pipe shall be used in standard length as far as possible. Cut length may be

used only where it is necessary to make up exact length.

The entire length of pipe shall be evenly supported on bed of the trench through out. Care shall be taken to prevent any sand, earth or other materials from entering into the pipes during laying. At the end of day's work the open end shall be suitably plugged.

4.4.5 FIXING : The pipe line shall be fixed in position as shown in the drawing or as directed by the Divisional Forest Officer. The pipe shall be fixed with G.I. clamps not less than 2 mm thick or with suitable diameter HDPE clamps. The clamps shall be fixed into the wall with M.S. nails not less than 40 mm long./ Wooden gutties etc. chromium plated screws with wooden gutties fixing the pipe line on internal wall surface.

4.4.6 MAKING JOINT : The joining of pipes and fittings generally shall be done by Butt weld with heat mirror jointing. The pipe shall be cut to desired length, Care shall be taken that profile of cut surfaces is not changed and the fibrous material shall be removed with scraper or knife. The butt weld jointing shall be made with electrical heated plated at the required temperature around 205, + or - 5 degree Centigrade. While jointing, care shall be taken that formation of the rim at end of pipe after heating by hot plate should be made uniform and complete on both the ends. Holding and pressing of pipe is done manually or mechanically to give the leak proof joint.

4.4.7 DETACHABLE JOINT : Detachable joints shall be made where pipes of different materials have to be jointed or as specified in the schedule. The flanges are first pushed over the pipe ends and a rim is made by heating the pipe end in a suitable device to 70-180 Centigrade and welding pre-heated rim of the pipe.

4.4.8 DEWATERING : In case of underground pipes, the contract rate shall include bailing or pumping out all the water till completion of work if accumulated during the progress of work either from seepage, springs, rain or any other cause.

4.4.9 TESTING : Solvent welded pipe shall not be pressure tested until at least 24 hours after the last solvent cemented joint has been done. All control valves shall be positioned open for the duration of the test and open end closed with water tight fittings. The testing pressure on completion of the work shall not be less than 1.5 time the working pressure of the pipes.

Pressure shall be applied either by hand pump or power driven pump. Pressure gauges shall be correctly positioned and closely observed to ensure that at no time are the test pressure exceeded. The systems shall be slowly and carefully filled with water to avoid surge pressure or water hammer. Air vents shall be open at all high points so that air may be expelled from the system during filling.

When the system has been fully charged with water and air displaced from the line air vent shall be closed and the line initially inspected for seepage at joints and firmness of supports under load. Pressure is reached. Without any additional requirement of make-up-water the test pressure should not fall more than 0.02 MPa (0.2 kg./sq.cm) at the end of one hour test duration.

4.5 PVC PIPING WORK FOR WATER SUPPLY :

4.5.1 GENERAL : The item includes supplying of PVC pipes with fittings of specified diameter including laying, fixing, cutting, joining, painting etc. for vent, over flow, waste water pipe line etc.

4.5.2 MATERIAL : The pipes and fittings shall conform to series IV of IS 4985-1978, PVC pipes and fittings shall be free from cracks, flaws and defects and shall be able to withstand a pressure as mentioned in the schedule of quantities.

4.5.3 EXAMINING : Before laying the pipe line, it shall be first examined for damages and cracks, No cracked or damaged pipe and fittings shall be used in the work and they shall be removed from the site by the contractor at his own cost and charge.

4.5.4 CLEANING : All the pipes and fittings shall be thoroughly cleaned with brush and washed if necessary to remove any accumulated stone, soil or dirt inside and out side surfaces.

4.5.5 TRENCHES : The trench bottom shall be carefully examined for the presence of hard objects such as flints, rock projection or tree roots etc. Pipe shall be embedded in sand or soft soil, free from rock & gravel, back fill 150mm above the pipe shall also be of fine sand or soft soil. Pipe shall not be painted. The width of trench shall not be less than out side diameter of pipe plus 300 mm in case of gravel soils. Pipe shall be laid at-least 900 mm below the ground level (measured from the surface of the ground to the top of pipe).

4.5.6 LAYING : The pipes shall be carefully laid straight to the correct alignment in gradients as indicated in the drawing. All the pipe shall be used in standard length as far as possible. Cut length may be used only where it is necessary to make up exact length. The entire length of pipe shall be evenly supported on bed of the trench through out. Care shall be taken to prevent any sand, earth or other materials from entering into the pipes during laying. At the end of day's work the open end shall be suitably

plugged.

4.5.7 FIXING : The pipe line shall be fixed in position as shown in the drawing or as directed by the Divisional Forest Officer. The pipe shall be fixed with G.I. clamps not less than 2 mm thick or with suitable PVC clamps, The clamps shall be fixed into the wall with G.I. nails not less than 40 mm long and wooden gutties.

Spacing between clamps for fixing internal piping shall be as given below :

| Pipe dia | For Horizontal Runs | For Vertical Runs |
|----------|---------------------|-------------------|
| 20 mm | 700 mm | 1050 mm |
| 25 mm | 750 mm | 1125 mm |
| 32 mm | 825 mm | 1240 mm |
| 40 mm | 975 mm | 1460 mm |
| 50 mm | 975 mm | 1460 mm |

4.5.8 MAKING JOINT : The jointing of pipes and fittings generally shall be done with approved make cement solvent including making surface rough. The pipe shall be cut to desired length. Care shall be taken that that profile or cut surfaces shall not be changed and the fibrous material shall be removed with scraper or knife.

4.5.9 DETACHABLE JOINT : Detachable joints shall be made where pipes of different materials have to be jointed or as specified in the schedule. The flanges are first pushed over the pipe ends and jointing shall be made by cement solvent.

4.5.10 PAINTING : If mentioned in schedule of work, the exposed pipe line shall be painted with two coats of approved oil paint of matching colour over a coat of primer. Underground pipe line shall not be painted.

4.5.11 DEWATERING : In case of underground pipes, the contract rate shall include bailing or pumping out all the water till completion or work if accumulated during the progress of work either from seepage, springs, rain or any other cause.

4.5.12 TESTING : Please refer clause No.4.4.09

4.6 GUN METAL/ BRASS FULL WAY VALVE :

4.6.1 GENERAL : The item includes provision of full way (gate or globe) valve of specified diameter as mentioned in the schedule including fixing. Full way valve is a valve suitable for controlling or stopping the flow in water supplylines.

4.6.2 MATERIAL :

Full way valve shall be of either Brass fitted with a cast iron hand wheel or Gun metal fitted with a C.I. hand wheel as the case may be and shall be of Gate valve type opening full way and of the size as specified conforming to IS 778. The weight of the full way gate valve shall be as per the table given below with a tolerance of 5 percent.

| Diameter in mm | Flanged arch (Kg) | Screwed arch (Kg) |
|----------------|-------------------|-------------------|
| 15 | 1.021 | 0.567 |
| 20 | 1.503 | 0.680 |
| 25 | 2.495 | 1.077 |
| 32 | 3.232 | 1.559 |
| 40 | 4.082 | 2.268 |
| 50 | 6.691 | 3.232 |
| 65 | 10.149 | 6.804 |
| 80 | 13.381 | 8.845 |

4.6.3 FIXING : The valves shall be fixed in position in the pipeline as shown in the drawing or as directed with necessary socket or union, nuts etc. The screwed, flanged joint shall be made with few turns of fine hemp yarn dipped in linseed oil taken over the threaded ends to obtain complete water tightness.

4.6.4 TESTING : The joints shall be tested to a hydraulic pressure of 1 MPa (10 kg/cm) 2 along with the testing of pipe line.

4.7 WATER METER :

4.7.1 GENERAL : The item includes provision of Water meter with or without end flanges or non-return valve of specified diameter as mentioned in the schedule with strainer, sockets, flange, union, nuts etc. including fixing and testing.

4.7.2 MATERIAL : Water Meter shall conform to IS 779 and should have ISI certification mark. Non return valve and strainer shall be of the same diameter as that of water meter. Strainer, sockets, flange, union, union nuts, rubber packing etc. shall be as per the description of item.

4.7.3 FIXING : Water meter shall be fixed in position on the inlet pipe line and the joints shall be made either screwed or flanged with necessary sockets, flanges and union nuts as required or as directed by the Divisional Forest Officer.

4.7.4 SCREWED JOINT : A few turns of fine hemp yarn dipped in linseed oil shall be taken over the threaded ends to obtain complete water tight joint.

4.7.5 FLANGED JOINT : The flange joint shall be made for flange type water meter and the joint shall be as per the specification of flanged joint.

4.7.6 TESTING : The joints shall be tested to a hydraulic pressure of 1 MPa (10 kg/cm) 2 along with testing of pipe line for a minimum duration of two hours.

4.8 PRESSURE REDUCING VALVE:

4.8.1 GENERAL : The item includes provision of pressure reducing valve of specified diameter as mentioned in the schedule including fixing.

4.8.2 MATERIAL: Pressure reducing valve is a device with suitable means of connection for insertion in a vertical pipe line for controlling the water pressure. Valve shall be of brass and shall be vertical flow type, conforming to IS 9739-1981.

4.8.3 FIXING : The valve shall be fixed in position on the pipe line as shown in the drawing or as directed. The screwed or flanged joint shall be made to obtain complete water tight joint.

4.8.4 TESTING : The joints shall be tested to a hydraulic pressure of 1MPa (10 kg/cm²) along with testing of pipe line for a minimum duration of 2 hrs.

4.9 CAST IRON WATER QUALITY PIPING WORK :

4.9.1 GENERAL : The item includes the provision of supplying water quality cast iron pipe of specified diameter including cutting, laying, fixing, and painting the pipe line.

4.9.2 MATERIAL : The pipes shall be centrifugally cast (spun) Iron Pressure pipe conforming to IS 1536 and shall be of class “LA”, ‘A’ or “B”. These shall be of socket and spigot or double flanged. All the pipes shall be cylindrical reasonably true with inner and outer surfaces and nearly concentric as practicable. The outer surface shall be smooth, sound, free from pin holes, cracks and other imperfections. The pipes shall be treated with solution of Dr. Angus Smith’s solution. The coated surface shall give glossy finish. The table showing the dimensions & weight of different diameter of pipes is given below:

CENTRIFUGALLY CAST (SPUN) IRON ‘WATER QUALITY’ PIPES

Tolerances : a) Length ± 25 mm (b) weight 5% (c) Thickness ± (1+0.05e)mm Value of ‘e’ for

- (i) LA class pipe e = 10/12 (7 + 0.02 DN)
- (ii) A class pipe e = 11/12 (7 + .02 DN)
- (iii) B class pipe e = (7 + 0.02 DN)

CENTRIFUGALLY CAST (SPUN) IRON ‘WATER QUALITY’ PIPES WEIGHT FOR SOCKET & SPIGOT PIPES (IS 1536-2001)

| Nom. Dia | Class | Barrel | | | | Socket Mass | Total weight for one working length ‘L’ in meter | | | | | |
|----------|-------|------------|-----------------|------------|---------------|-------------|--|------|-----|------|-----|-----|
| | | Lead joint | Push - on joint | Thick-ness | Mass for 1 Mt | | 3.66 | 4 | 4.5 | 5 | 5.5 | 6 |
| DN mm | | DE mm | DE mm | E mm | Kg. | Kg. | Kg. | Kg. | Kg. | Kg. | Kg. | Kg. |
| 80 | LA | 98 | 95 | 7.2 | 14.7 | 5.5 | 59.0 | 64.0 | - | 79.0 | - | - |

| | | | | | | | | | | | | |
|------|----|------|------|------|-------|-------|--------|--------|--------|--------|--------|--------|
| | A | 98 | 95 | 7.9 | 16.0 | 5.5 | 64.0 | 70.0 | 78.0 | 86.0 | - | - |
| | B | 98 | 95 | 8.6 | 17.3 | 5.5 | 69.0 | 74.0 | 83.0 | 92.0 | - | - |
| 100 | LA | 118 | 115 | 7.5 | 18.6 | 7.1 | 75.0 | 82.0 | 91.0 | 100.0 | 109.0 | 119.0 |
| | A | 118 | 115 | 8.3 | 20.5 | 7.1 | 82.0 | 89.0 | 99.0 | 109.0 | 120.0 | 130.0 |
| | B | 118 | 115 | 9.0 | 22.0 | 7.1 | 88.0 | 95.0 | 106.0 | 117.0 | 128.0 | 139.0 |
| 125 | LA | 144 | 141 | 7.9 | 24.2 | 9.2 | 98.0 | 106.0 | 118.0 | 130.0 | 142.0 | 154.0 |
| | A | 144 | 141 | 8.7 | 26.4 | 9.2 | 106.0 | 115.0 | 128.0 | 141.0 | 155.0 | 168.0 |
| | B | 144 | 141 | 9.5 | 28.7 | 9.2 | 114.0 | 124.0 | 138.0 | 153.0 | 167.0 | 181.0 |
| 150 | LA | 170 | 167 | 8.3 | 30.1 | 11.5 | 122.0 | 132.0 | 147.0 | 162.0 | 177.0 | 192.0 |
| | A | 170 | 167 | 9.2 | 33.2 | 11.5 | 133.0 | 144.0 | 161.0 | 178.0 | 194.0 | 211.0 |
| | B | 170 | 167 | 10.0 | 35.9 | 11.5 | 143.0 | 155.0 | 173.0 | 191.0 | 209.0 | 227.0 |
| 200 | LA | 222 | 219 | 9.2 | 44.0 | 16.5 | 178.0 | 193.0 | 215.0 | 237.0 | 259.0 | 281.0 |
| | A | 222 | 219 | 10.1 | 48.1 | 16.5 | 193.0 | 209.0 | 233.0 | 257.0 | 281.0 | 305.0 |
| | B | 222 | 219 | 11.0 | 52.1 | 16.8 | 207.0 | 225.0 | 251.0 | 278.0 | 304.0 | 329.0 |
| 250 | LA | 274 | 271 | 10.0 | 59.3 | 22.9 | 240.0 | 260.0 | 290.0 | 319.0 | 349.0 | 379.0 |
| | A | 274 | 271 | 11.0 | 65.0 | 22.9 | 261.0 | 283.0 | 315.0 | 348.0 | 380.0 | 413.0 |
| | B | 274 | 271 | 12.0 | 70.6 | 22.9 | 281.0 | 305.0 | 341.0 | 376.0 | 411.0 | 447.0 |
| 300 | LA | 326 | 323 | 10.8 | 76.5 | 29.8 | 310.0 | 336.0 | 374.0 | 412.0 | 450.0 | 489.0 |
| | A | 326 | 323 | 11.9 | 84.0 | 29.8 | 337.0 | 366.0 | 408.0 | 450.0 | 492.0 | 534.0 |
| | B | 326 | 323 | 13.0 | 91.4 | 29.8 | 364.0 | 395.0 | 441.0 | 487.0 | 533.0 | 578.0 |
| 350 | LA | 378 | 375 | 11.7 | 96.3 | 37.5 | 390.0 | 423.0 | 471.0 | 519.0 | 567.0 | 615.0 |
| | A | 378 | 375 | 12.8 | 105.0 | 37.5 | 422.0 | 458.0 | 510.0 | 563.0 | 615.0 | 668.0 |
| | B | 378 | 375 | 14.0 | 114.5 | 37.5 | 457.0 | 495.0 | 553.0 | 610.0 | 667.0 | 725.0 |
| 400 | LA | 429 | 426 | 12.5 | 116.9 | 46.3 | 474.0 | 514.0 | 572.0 | 631.0 | 690.0 | 748.0 |
| | A | 429 | 426 | 13.8 | 128.7 | 46.3 | 517.0 | 561.0 | 625.0 | 690.0 | 754.0 | 819.0 |
| | B | 429 | 426 | 15.0 | 139.5 | 46.3 | 557.0 | 604.0 | 674.0 | 744.0 | 814.0 | 883.0 |
| 450 | LA | 480 | 477 | 13.3 | 141.0 | 56.0 | 572.0 | 620.0 | 690.0 | 761.0 | 832.0 | 902.0 |
| | A | 480 | 477 | 14.7 | 156.0 | 56.0 | 627.0 | 680.0 | 758.0 | 836.0 | 914.0 | 992.0 |
| | B | 480 | 477 | 16.0 | 169.0 | 56.0 | 675.0 | 732.0 | 816.0 | 901.0 | 986.0 | 1070.0 |
| 500 | LA | 532 | 529 | 14.2 | 165.2 | 66.0 | 671.0 | 727.0 | 809.0 | 892.0 | 974.0 | 1057.0 |
| | A | 532 | 529 | 15.6 | 181.0 | 66.0 | 728.0 | 790.0 | 880.0 | 971.0 | 1061.0 | 1152.0 |
| | B | 532 | 529 | 17.0 | 196.7 | 66.0 | 786.0 | 853.0 | 951.0 | 1049.0 | 1148.0 | 1246.0 |
| 600 | LA | 635 | 632 | 15.8 | 219.8 | 89.3 | 894.0 | 968.0 | 1162.0 | 1188.0 | 1298.0 | 1408.0 |
| | A | 635 | 632 | 17.4 | 241.4 | 89.3 | 973.0 | 1055.0 | 1141.0 | 1272.0 | 1404.0 | 1544.0 |
| | B | 635 | 632 | 19.0 | 262.9 | 89.3 | 1052.0 | 1141.0 | 1272.0 | 1404.0 | 1535.0 | 1667.0 |
| 700 | LA | 738 | 735 | 17.5 | 283.2 | 116.8 | 1153.0 | 1250.0 | 1391.0 | 1538.0 | 1675.0 | 1816.0 |
| | A | 738 | 735 | 19.3 | 311.6 | 116.8 | 1257.0 | 1363.0 | 1519.0 | 1675.0 | 1830.0 | 1986.0 |
| | B | 738 | 735 | 21.0 | 338.2 | 116.8 | 1355.0 | 1470.0 | 1639.0 | 1808.0 | 1977.0 | 2146.0 |
| 750 | LA | 790 | 787 | 18.3 | 317.2 | 131.7 | 1293.0 | 1400.0 | 1559.0 | 1718.0 | 1876.0 | 2035.0 |
| | A | 790 | 787 | 20.2 | 348.9 | 131.7 | 1409.0 | 1527.0 | 1702.0 | 1876.0 | 2051.0 | 2225.0 |
| | B | 790 | 787 | 22.0 | 380.6 | 131.7 | 1525.0 | 1644.0 | 1844.0 | 2029.0 | 2225.0 | 2415.0 |
| 800 | LA | 842 | 839 | 19.2 | 354.9 | 147.8 | 1447.0 | 1567.0 | 1745.0 | 1922.0 | 2100.0 | 2277.0 |
| | A | 842 | 839 | 21.1 | 389.1 | 147.8 | 1572.0 | 1704.0 | 1899.0 | 2093.0 | 2288.0 | 2482.0 |
| | B | 842 | 839 | 23.0 | 423.1 | 147.8 | 1696.0 | 1840.0 | 2052.0 | 2263.0 | 2475.0 | 2686.0 |
| 900 | LA | 945 | 942 | 20.8 | 421.8 | 182.6 | 1763.0 | 1910.0 | 2126.0 | 2342.0 | 2558.0 | 2773.0 |
| | A | 945 | 942 | 22.9 | 474.3 | 182.6 | 1918.0 | 2080.0 | 2317.0 | 2554.0 | 2791.0 | 3028.0 |
| | B | 945 | 942 | 25.0 | 516.6 | 182.6 | 2073.0 | 2249.0 | 2507.0 | 2766.0 | 3024.0 | 3282.0 |
| 1000 | LA | 1048 | 1045 | 22.5 | 518.3 | 222.3 | 2119.0 | 2295.0 | 2555.0 | 2814.0 | 3073.0 | 3392.0 |
| | A | 1048 | 1045 | 24.8 | 570.0 | 222.3 | 2308.0 | 2502.0 | 2787.0 | 3072.0 | 3357.0 | 3642.0 |
| | B | 1048 | 1045 | 27.0 | 619.2 | 222.3 | 2489.0 | 2699.0 | 3009.0 | 3318.0 | 3621.0 | 3938.0 |
| 1050 | LA | 1124 | 1118 | 23.6 | 583.4 | 309.6 | 2445.0 | 2643.0 | 2935.0 | 3227.0 | 3518.0 | 3810.0 |
| | A | 1124 | 1118 | 26.0 | 641.2 | 309.6 | 2656.0 | 2874.0 | 3195.0 | 3516.0 | 3836.0 | 4157.0 |
| | B | 1124 | 1118 | 29.0 | 713.3 | 309.6 | 2920.0 | 3163.0 | 3519.0 | 3876.0 | 4233.0 | 4589.0 |

4.9.3 UNLOADING : The pipe shall be unloaded where they are required. Where mechanical handling facility are not available, pipes weighing upto 60 kg shall be handled by two persons by hand passing and heavier pipes shall be unloaded from the lorry or wagon by holding them in loops, formed with ropes and sliding over plank set not steeper than 45 degrees. Two ropes always shall be used and only one pipe shall be unloaded at a time. Under no circumstances shall pipes be thrown down from the carriers or be dragged or rolled along hard surfaces. The pipes shall be checked for any visible damage while unloading and shall be sorted out for reclamation.

4.9.4 STORING : The pipes shall be lined upon on one side of the alignment of the trench, socket facing upgrade when line runs uphill and up stream when line runs on level ground. Each stack shall contain pipes of same class and size. Storage shall be done on firm, level and clean ground. Wedges shall be provided at the bottom layer to keep the stack stable.

4.9.5 CLEANING : The pipes shall be thoroughly cleaned with brush and washed if necessary to remove any accumulated stone, soil or dirt inside and inside of socket and outside of the spigot shall also be cleaned in similar way.

4.9.6 EXAMINATION : Before pipe is laid it shall be first examined for damage and cracks. No cracked or damaged pipe shall be used. The pipe shall be tested with a hammer to prove its soundness

4.9.7 DAMAGED MATERIAL : If any material found damaged or cracked, the same shall not be used in the work. The contractor has to replace the same at his own cost and charges.

4.9.8 TRENCHES : The depth of the trenches shall not be less than 1000 mm measured from the top of the pipe to the surface of the ground under roads and not less than 750 mm elsewhere. The width of the trench shall be the nominal diameter of the pipeline plus 400mm, but it shall not less than 550 mm in case of all kind of soil, excluding rock and not less than 1000 mm in case of rock.

Trench shall be so deep that the pipes may be laid to the required alignment and at required depth. The width of trench at bottom between face of sheeting shall be such as to provide not less than 200 mm clearance on either side of the pipe. Trenches shall be of such extra width, when required as will permit the convenient placing of timber supports strutting and planking handling of specials etc. The bed of trench, in soft or made up earth, shall be well watered and rammed before laying the pipes and depression, if any, shall be properly filled with earth and consolidated in 20 cm layers.

If the trench bottom is extremely hard or rocky or loose stoney soil, the trench shall be excavated 150mm below the trench grade. Rocks, stones or other hard substances from the bottom of the trench shall be removed & trench brought back to the required grade by filling with selected fine earth or sand or fine murrum & compact so as to provide a smooth bedding for pipe.

After the excavation of the trench is completed, hollows shall be cut at the required position to receive the socket of the pipe. The barrels of the pipes shall rest through their entire length on the solid ground that sufficient space left for jointing the under side of the pipe joints. These socket holes shall be refilled with sand after jointing the pipe.

The trench shall be kept free from water shoring and timbering shall be provided wherever required. Excavation below water table shall be done after dewatering the trenches. The road crossing shall be excavated half at a time and where the pipe line/drain crosses on existing road after the pipe have been laid in the first half and the trench refilled. Care shall be taken not to disturb the electrical & communication cable net with during the course of excavation.

4.9.9 LOWERING : The pipe shall then be placed in trenches by means of proper sheer legs, chains and other tacts and shall be properly driven home. In no case pipe shall be rolled or dropped into the trench. One end of rope may be tied to a wooden or steel Pag or driven into ground and other end hold by men which when slowly released till lower the pipe into trench.

4.9.10 LAYING : The pipes shall be carefully laid straight to correct alignment in raising or falling gradients. The socket end of the pipe shall face uphill. All the pipe shall be used in standard length as far as possible. Cut length may be used only where it is necessary to make up exact length. While jointing the spigot it should be neatly placed into the socket for full length and properly supported. The pipe shall be carefully packed underneath so that they shall bear loads arising from traffic evenly through out their whole length. The entire length of pipe shall be supported on bed of the trench evenly through out. Care shall be taken to prevent any sand, earth or other materials from entering into the pipes during laying. At the end of the day's work the open end shall be suitably plugged.

No pipe shall be laid until the trench has been excavated to its required depth for a distance of about 5 M in front of the pipe to be laid. No pipe shall be covered until it has been passed by the Divisional Forest Officer.

In unstable soils, such as soft soil and dry lumpy soil it shall be checked whether the soil can support the pipe and if required, suitable special foundation shall be provided.

Where the soils are drastically affected by extremes of saturation and dryness, those soils are subjected to extraordinary shrinkage which from wide and deep cracks in the earth surface may result in damage to

underground pipe because of tight gripping bond between pipe and clay, subjecting to it excessive stresses as the clay shrinks. In such case an envelope of minimum 100 mm of tamped sand shall be made around the pipe line to avoid any bonding.

In places where rock is encountered, cushion of fine earth or sand shall be provided for a depth of 150mm by excavating extra depth of the trench where the gradient of the bad slopes is more than 30 depths, it may necessary do and or fine pipe against sliding downwards.

4.9.11 FIXING: The contractor shall first get the layout for pipe line approved by the Divisional Forest Officer as may be required by the bye-laws. The pipe line shall be so fixed / laid as not to expose to the heat or subject to any injury or risk to the pipe. The socket end of the pipe shall be facing up. All the pipes shall be used in standard length as far as possible. Cut length may be used only where it is necessary to make up exact length

4.9.12 THRUST BLOCK : Thrust blocks are required to transfer the resulting hydraulic thrust from the fittings of pipe on to a larger load bearing soil section. Thrust blocks shall be installed wherever there is a change in the direction/size of the pipe line or the pressure line diagram, or the pipe line ends at a dead end. If necessary, thrust blocks may be constructed at valves also. Thrust block shall be constructed taking into account the pipe size, water pressure, type of filling, gravity component when laid on slopes and the type of soil. In case of pipe line laid in soft soil, joints/couplings are to be anchored on each side by providing side thrust blocks without restricting the coupling.

Pipes on slopes need be anchored only when there is a possibility of the backfill around the pipe sloping down the hill and carrying the pipe with it. Generally for slopes upto 30 degrees, good, well drained soil carefully damped in layers of 100mm under and over the pipe, right up to the top of trench will not require anchoring.

For steeper slopes, one out of every three pipes shall be held by straps fastened to vertical supports anchored in concrete.

4.9.13 BACK FILLING: Back filling shall follow the pipe installation as closely as possible to protect pipe from falling boulders, eliminating possibility of lifting of the pipe due to flooding of open trench and shifting pipe out of line by caved in soil.

The soil under the pipe and coupling shall be solidly tamped. The initial back fill material shall be free of large stones and dry lumps.

In bags and Monshers gravel or crushed stone may be used for this purpose. The initial back fill shall be placed evenly in a layer of 100 mm thick and consolidated up to a cushion of at least 300 mm cover over the pipe. Joints shall be taken care to resist the movement of the pipe due to pressure while testing.

4.9.14 TESTING : After a new pipe has been laid, jointed and back filled (or any valved section thereof), it shall be subjected to the following two tests :

- a) Pressure test at a pressure of at least double the maximum working pressure-pipe and joints shall be absolutely water tight under the test.
- b) Leakage test (to be conducted after the satisfactory completion of the pressure test) at a pressure to be specified by the authority for a duration of two hours.

Hydrostatic Tests :

Portions of the line shall be tested by subjecting to pressure test as the laying progresses before the entire line is completed. In this way any error of workmanship will be found immediately and can be corrected at a minimum cost. Usually the length of the section to be tested shall not exceed 500 m.

Where any section of a main is provided with concrete thrust blocks or anchorages, test shall not be made until atleast two days have elapsed.

Prior to testing, enough back fill as described in 4.9.12 shall be placed over the pipe line to resist upward thrust. All thrust blocks forming part of the finished line shall have been sufficiently cured and no temporary bracing shall be used.

The open end of the section shall be sealed temporarily with an end cap having an outlet which can serve as an air relief vent or for filling the line, as may be required. The blind face of the end cap shall be properly braced during testing by screw jacks and wooden planks or steel plate The section of the line to be tested shall be filled with water manually or by a low pressure pump. Air shall be vented from all high spots in the pipe line before making the pressure strength test because entrapped air gets compressed and causes difficulty in raising the required pressure for the pressure strength test.

The test pressure shall be gradually raised at the rate of approximately one kg/ sqcm/ mm. The duration of the test period if not specified shall be sufficient to make a careful check on the pipe line section.

Procedure for pressure test :

Each valved section of the pipe shall be slowly filled with water and all air shall be expelled from the pipe

through hydrants and blow offs. If these are not available at high places, necessary tapping may be made at points of highest elevation before the test is made and plugs inserted after the tests have been completed.

If the trench has been partially back-filled the specified pressure based on the elevation of the lowest point of the line or section under test and corrected to the elevation of the test gauge, shall be applied by means of a pump connected to the pipe in a manner satisfactory to the Divisional Forest Officer. The duration of the test shall not be less than 5 minutes.

Examination under Pressure : All exposed pipes, fittings, valves, hydrants and joints should be carefully examined during the open-trench test. When the joints are made with lead, all such joints showing visible leaks shall be recaulked until tight. When the joints are made with cement and show seepage or slight leakage, such joints shall be cut out and replaced as directed by the authority. Any cracked or defective pipes, fittings, valves or hydrants discovered in consequence of this pressure test shall be removed and replaced by sound material and the test shall be repeated until satisfactory to the Divisional Forest Officer.

If the trench has been back-filled to the top, the section shall be first subjected to water pressure normal to the area and the exposed parts shall be carefully examined. If any defects are found, they shall be repaired and the pressure test repeated until no defects are found. The duration of the final pressure tests shall be at least one hour.

Procedure for Leakage Test :

Leakage is defined as the quantity of water to be supplied into the newly laid pipe, or any valved section thereof, necessary to maintain the specified leakage test pressure after the pipe has been filled with water and the air expelled.

No pipe installation shall be accepted until the leakage is less than the number of cm³/h determined by the formula :

$$ql = ND\sqrt{P}$$

$$\frac{\text{-----}}{3.3}$$

Where ql = the allowable leakage in cm³/h. 3

N = number of joints in the length of the pipe line.

D = diameter in mm, and

P = the average test pressure during the leakage testing kg/cm² . 2

Variation from Permissible Leakage : Should any test of pipe laid in position discloses leakage greater than that specified in above para., the defective joints shall be repaired until the leakage is within the specified allowance.

4.9.15 DEWATERING : The contract rate shall include bailing or pumping out all the water if accumulated during the progress of the work either from rain, seepage, springs or any other cause.

4.10 SPECIALS FOR C.I. WATER SUPPLY PIPE LINE :

4.10.1 GENERAL : The item includes supplying cast iron water quality or M.S. specials of specified diameter for C.I. water supply pipe including laying, fixing and painting the specials.

4.10.2 MATERIALS : The specials for cast iron water quality pipe shall be conforming to IS 1538 & 13382 with socket and spigot or monolithic double flanged. All the fittings shall be cylindrical, reasonably true with inner and outer surfaces and nearly concentric as practicable. The outer surface shall be smooth, sound, free from pin holes, cracks and other imperfections. M.S. specials shall be made out of M.S. plate of thickness of 6 mm for pipes upto 100mm and 8 mm thick for pipes above 100 mm to 300. 10 mm thick for pipe above 300 mm.

4.10.2 A : M.S. specials shall be treated with Anticorrosive coating of Bituminous based coro coat.

4.10.3 CLEANING : The specials and fittings shall be thoroughly cleaned with brush and washed if necessary to remove any accumulated stone, soil or dirt inside the socket and outside of the spigot.

4.10.4 EXAMINING : Before special is laid, it shall be first examined for damage and cracks. No cracked or damaged pipe shall be used. The pipe shall be tested with a hammer to prove its soundness.

4.10.5 DAMAGED MATERIAL : If any material found damaged or cracked, the same shall not be used in the work. The contractor has to replace the same at his own cost and charges.

4.10.6 LOWERING : The specials shall then be placed in trenches by means of proper sheer legs, chains and other tacts and shall be properly driven home.

4.10.7 FIXING : The specials shall be fixed by means of lead or flanged joint on C.I. Pipe line wherever

required and as shown in the drawing or as directed by the Divisional Forest Officer.

4.10.8 TESTING : Joints shall be tested to a hydraulic pressure of 10 kg/cm² alongwith testing of pipe line and shall be maintained for minimum two hours. All leakages, defects etc. shall be rectified.

4.10.9 DEWATERING : The contract rate shall include bailing or pumping out all the water if accumulated during the progress of the work either from rain, seepage, springs or any other cause till the completion of work.

4.11 LEAD JOINT :

4.11.1 GENERAL : The item includes making lead joints for C.I.water quality pipes and fittings/specials including testing etc.

4.11.2 MATERIAL : Lead shall be conforming to IS 782 and of good quality manufactured by Hindustan zinc or equivalent. Fine hemp yarn shall be the best available in the market.

4.11.3 PREPARATION : Outside of the spigot and inside of the socket shall be thoroughly cleaned with brush. The spigot shall be carefully centred in the socket by one or more laps of spun hemp yarn twisted into ropes of uniform thickness thoroughly soaked in hot coal-tar or bitumen and cooled before use.

4.11.4 POURING : Pouring of lead shall be done by means of ropes covered with clay or by using special leading rings. The lead shall be melted rendering it thoroughly fluid and each joint shall be filled in one pouring.

4.11.5 CAULKING : The caulking shall be carried out with molten lead. Hemp yarn shall be driven into the bottom of the socket and leave the space required. The molten lead shall then be run in sufficient quantity so that after being caulked solid, the lead may project 3 mm beyond the face of the socket against the outside of the spigot, but must be flushed with the outside edge of the socket.

The lead taken from the pot shall be run hot into the joint and the joint filled in one running. The joint shall be caulked well, by a suitable caulking tool and 2 kg hammer and the joint left neat and smooth. In case C.I. fittings are also conforming to the same specification that of pipes, the consumption of lead will be worked out on the basis of actual consumption for each joints.

The following table shows consumption of the weight of lead & yarn per joint as per IS 3114 : 1994

| Nominal Internal Dia in mm | Spun Yarn Mass in Kg. | Lead Mass in kg. | Depth of Lead Joint MM |
|----------------------------|-----------------------|------------------|------------------------|
| 80 | 0.17 | 1.8 | 45 |
| 100 | 0.23 | 2.2 | 45 |
| 125 | | 2.6 | 45 |
| 150 | 0.34 | 3.4 | 50 |
| 200 | 0.57 | 5.0 | 50 |
| 250 | 0.74 | 6.1 | 50 |
| 300 | 0.82 | 7.2 | 55 |
| 350 | 1.17 | 8.4 | 55 |
| 400 | 1.33 | 9.5 | 55 |
| 450 | 1.84 | 14.0 | 55 |
| 500 | 1.99 | 15.0 | 60 |
| 600 | 2.83 | 19.0 | 60 |
| 700 | | 22.0 | 60 |
| 750 | 3.52 | 25.0 | 60 |
| 800 | | 31.5 | 65 |
| 900 | 4.25 | 35.0 | 65 |
| 1000 | | 41.0 | 65 |
| 1100 | | 46.0 | 65 |
| 1200 | 6.01 | 52.0 | 70 |
| 1500 | | 66.5 | 75 |

- NOTE :** i) The quantities of lead given are on average basis and a variation of 10 percent is permissible .
- ii) Before pipe are jointed on large scale, three a four sample joints shall be made and the average consumption of lead per joint shall be got approved by the Divisional Forest Officer.

4.11.6 TESTING : The pipe line after being laid and jointed shall be tested under the supervision of the Divisional Forest Officer. The testing shall be carried out by the contractor at his own cost and charges. Any joint found leaking shall be redone and all leaking pipes removed and replaced without extra cost.

The length of pipes to be tested shall be first filled with water from a higher section of pipe and the test pressure is applied. The test pressure shall be 10 kg per square centimeters and shall be maintained for two hours continuously.

4.11.7 DEWATERING : The contract rate shall include bailing out all the water if accumulated during the progress of the work either from rain, seepage, springs or any other cause till the completion of work.

4.12 G M GATE VALVE CHAMBER :

4.12.1 GENERAL : The item includes construction of brick masonry valve chamber of size as specified in this schedule including providing M.S./G.I. frame and cover over R.C.C pre-cast cover with or without surface box.

4.12.2 MATERIAL : Brick work, plastering, concreting etc. shall be as per general specification . Precast RCC cover slab, surface box, C.I/M.S frame and cover etc. shall be size and weight as specified in the schedule.

4.12.3 CONSTRUCTION :

a) Foundation concrete of mix 1:4:8 shall be of 150 mm thick with 150 mm offset around or as specified in the schedule.

b) Brick masonry in cement mortar 1:4 as specified.

c) Plastering inside and outside surfaces of walls in two courses using cement mortar 1:3 of thickness as specified mixed with water proofing compound of specified Quality including inner surfaces finished smooth with neat cement punning.

4.12.4 RCC PRECAST/CAST IRONCOVERS

4.12.4.1 RCC PRECAST COVER (for chambers of size upto 600 x 600 mm) : Chamber cover shall be casted as shown in the drawing having minimum 75 mm thick in cement concrete 1:2:4 or as specified in the schedule by using nominal reinforcement 100 kg/ Cum of concrete including shuttering, finishing, curing, placing in position etc.

4.12.4.2 CAST IRON/ M.S COVER : Cast iron/M.S cover of specified size and weight shall be supplied and placed over the chamber as directed. The cover shall be painted with 3 coats of black bitumastic paint.

4.12.05 DEWATERING : The water accumulated in the pit due to rain, seepage, springs or any other cause during the progress of work shall be pumped/bailed out till the completion of work.

4.13 C.I. SLUICE VALVE CHAMBER :

4.13.1 GENERAL : The item includes construction of brick masonry valve chamber of size as specified in this schedule including providing M.S./G.I. frame and cover over R.C.C pre-cast cover with or without surface box.

4.13.2 MATERIAL : Brick work, plastering, concreting etc. shall be as per general specification . Precast RCC cover slab, surface box, C.I/M.S frame and cover etc. shall be size and weight as specified in the schedule.

4.13.3 CONSTRUCTION :

a) Foundation concrete of mix 1:4:8 shall be of 150 mm thick with 150 mm offset around or as specified in the schedule.

b) Brick masonry in cement mortar 1:4 as specified.

c) Plastering inside and outside surfaces of walls in two courses using cement mortar 1:3 of thickness as specified mixed with water proofing compound of specified Quality including inner surfaces finished smooth with neat cement punning.

4.13.4 RCC PRECAST/CAST IRONCOVERS

4.13.4.1 RCC PRECAST COVER (for chambers of size above 1000 x 1000 mm) : Chamber cover shall be coated in minimum three equal parts or more as directed with lifting hooks as shown in the drawing. RCC slab shall be casted alongwith galvanised M.S. angle iron frame with stiffness and anchors made out of the sizes as specified in the schedule. The exposed portion of the angle frame shall be painted with the coats of silver paint over a a coat of primer.

RCC pre-cast slab shall be of 100 mm thick (unless otherwise specified) in cement concrete 1:2:4 of size

as specified in the drawing schedule by using nominal reinforcement 100 kg/ Cum of concrete including shuttering, curing etc. and shall be placed in position as directed. cast iron road surface of prescribed weight shall be fixed to the cover slab during casting the slab for key rod operation.

Road surface box shall be of size 100x125x150 mm conforming to IS 3950 having hinged and weighting not less than 14 kg. The surface box shall be fixed on top of the RCC cover slab during the casting of slab for key rod operation. The surface box shall be painted with 3 coats of black bitumastic paint.

4.13.4.2 CAST IRON/ M.S COVER : Cast iron/M.S cover of specified size and weight shall be supplied and placed over the chamber as directed. The cover shall be painted with 3 coats of black bitumastic paint.

4.13.5 DEWATERING : The water accumulated in the pit due to rain, seepage, springs or any other cause during the progress of work shall be pumped/bailed out till the completion of work.

4.14 FLANGES & FLANGED JOINT : (Screwed or welded Flanges)

4.14.1 GENERAL : The item includes supplying flanges and providing flanged joint for G.I./ M.S./ C.I pipes, fittings and specials including testing.

4.14.2 MATERIAL : The CI flanges shall be conforming to IS 3516 or IS 1536. The heavy quality G.I./ M.S. flanges shall be conforming to I.S.6392 having thickness not less than 20 mm for pipes having diameter beyond 80 mm and 12 mm for pipes having diameter below 80 mm including drilling holes in new flanges, jointing with the pipe by means of welding or screwed joint. Rubber insertion shall be of three ply not less than 3 mm thick of approved make or fiber board impregnated with chemically neutral mineral oil having smooth & hard surface weighing not less than 112 gm/mm thickness. Bolts, nuts and washers used shall be of good quality.

4.14.3 MAKING JOINT : Flanged joints shall be made by jointing the facing of the flange with the packing of rubber insertion and boiling up evenly on all sides. A thin layer of lead wool shall be provided for making the joints water tight where facing of the pipe is not true. The packing shall be of rubber insertion of three ply and of approved make and thickness. The packing should be of full diameter of the flange with proper pipe hole and bolt hole; cut even at both the inner and outer edges.

4.14.4 DEWATERING : The contract rate shall include bailing or pumping out all the water if accumulated during the progress of the work either from rain, seepage, springs or any other cause till the completion of work.

4.14.5 TESTING : The joints shall be tested along with pipe line after the pipe line is laid and jointed. The testing shall be as per the clause of testing of the pipe line

4.15 FLEXIBLE PUSH-ON JOINT (TYTON/ RING JOINT)

4.15.1 GENERAL : The item includes push-on joint with rubber ring for C.I. pipes, fittings and including testing.

4.15.2 MATERIAL : Rubber ring shall be moulded or tubular natural or synthetic rubber gasket conforming IS 12820.

4.15.3 JOINTING : The groove and the socket shall be thoroughly cleaned before inserting the rubber gasket while inserting the gasket it shall be made sure that it faces the proper direction and that it is correctly seated in the groove. After cleaning dirt or foreign materials from the plain end, non petroleum lubricant shall be applied in accordance with the pipe manufacturer's recommendations. The plain end of the pipe is pushed into the socket of the pipe and while pushing, the pipe shall be kept straight. If any deflections are to be made in the alignment, it may be made after the joint is assembled. The permissible ° deflection shall not be exceeded as per IS 3114 for socket and spigot rubber joint is 5 for 80 to 300 mm nom. bore, 4 ° for 350 to 400 mm nom bore and 3 ° for 450 to 750 mm nom bore pipe. A timber header shall be used between the pipe and crowbar or jack to avoid damage to the pipe while the plain end of the pipe is pushed into the socket either with a crowbar or jack or lever pulle

4.15.4 TESTING : The joints shall be tested along with pipe line after the pipe line is laid and jointed. The testing shall be as per the clause of testing of the pipe line

4.15.5 DEWATERING : The contract rate shall include bailing out all the water if accumulated during the progress of the work either from rain, seepage, springs or any other cause till the completion of work.

4.16 C. I. SLUICE VALVE :

4.16.1 GENERAL : The item includes supplying of C.I. Sluice Valve of specified diameter as mentioned in the schedule including fixing.

4.16.2 MATERIAL : The Sluice valve shall be of Class or pressure rating as specified in the schedule of quantities and conforming to I.S. 14846. The valve shall be of cast iron and / or spheroidal iron having non-rising spindle with hand wheel & spindle of stainless steel.

4.16.3 FIXING : The C.I. sluice valve shall be fixed in position as indicated in the drawing or as directed. They shall be fitted with the tail pieces on both sides by means of flange joints.

4.16.4 DEWATERING : The contract rate shall include bailing or pumping out all the water if accumulated during the progress of the work either from rain, seepage, springs or any other cause till completion of the work.

4.16.5 TESTING : The Sluice Valve and the joints shall be tested as per the clause of testing of the pipe line The testing shall be done along with the pipe line testing.

4.17 C.I. NON RETURN VALVE :

4.17.1 GENERAL : The item includes supplying of C.I. Non-Return Valve of specified size in the schedule of quantities including fixing.

4.17.2 MATERIAL : Non-return valve shall be conforming to IS 9338 or IS 5312 as specified in schedule of quantities. The body, domes, covers, stuffing box, thrust plates, hand wheel, wedges, gland and cap shall be of cast iron not less than of grade FG200 and all in side working parts should be of any non ferrous or ferrous materials such as gun metal. Valve of single door pattern swing type shall have test pressure of PN1.6(50 to 125 mm size), PN1.0 (150 to 300mm size),PN0.6 (350 to 600 mm size)as per IS 5312 (part.1). Valve of multi door pattern swing type shall have test pressure of PN0.6(400 to 1200 mm size), PN1.0 (400 to 1200mm size)as per IS 5312 (part 2).Valve shall be tested for the body and seat and the defective valve shall be replaced by the contractor at his own cost.

4.17.3 FIXING : The C.I. Non-Return valve shall be fixed in position as indicated in the drawing or as directed. They shall be fitted with the tail pieces on both sides by means of flange joints.

4.17.4 DEWATERING : The contract rate shall include bailing or pumping out all the water if accumulated during the progress of the work either from rain, seepage, springs or any other cause.

4.17.5 TESTING : The C.I. Non-Return valve shall be fixed in position shall be tested hydraulically to a minimum pressure as per testing clause of piping work. The testing shall be done along with the testing of pipe line.

4.18 FOOT-VALVE :

4.18.1 GENERAL : The item includes supplying of C.I. body. Foot-Valve of specified diameter as mentioned in the schedule including fixing.

4.18.2 MATERIAL : Foot-Valve shall be conforming to IS 4038 and with C.I. body not less than of grade FG200 and strainer with internal gun metal working parts. The valve shall be screwed end (25 to 150 mm size),flanged end (50 to 450 mm size), single disc type (up to 150 mm size), two disc type (exceeding 150 mm size), lift type (up to 100 mm size) The valve shall be tested for housing 0.6 MPa (6 kg/cm²) and for seat 0.2 MPa (2 kg/cm²) for 2 minutes as per IS 4038. The ball type foot valve with nitrile rubber ball and with bronze seat may be used as specified in the schedule of quantities. The defective Foot-Valve shall be replaced by the contractor at his own cost.

4.18.3 FIXING : Foot-valve shall be fixed in position as shown in the drawing or as directed. They shall be fitted by means of flange joints.

4.18.4 TESTING : The C.I. Foot-Valve and the joints shall be tested hydraulically to a minimum pressure as per testing clause of piping work .The testing shall be done along with the testing of pipe line.

4.19 AIR VALVE :

4.19.1 GENERAL : The item includes supplying of single, double action or kinetic air Valve of specified diameter as mentioned in the schedule including fixing.

4.19.2 MATERIAL : The Air Valve shall be of heavy quality conforming to IS 14845 with IS certification mark and isolation valve.. The body, domes, covers, stuffing box, thrust plates, wedges, gland and cap shall be of cast iron not less than of grade 20 and inside working parts should be of any non-ferrous or ferrous materials.

4.19.3 FIXING : The Air Valve shall be fixed in position as indicated in the drawing or as directed. They shall be fitted by means of flange joints or screwed joint to the pipe line.

4.19.4 TESTING : The Air Valve and the joints shall be tested hydraulically to a minimum pressure as per testing clause of piping work. The testing shall be done along with the testing of pipe line.

4.20 BUTTER FLY VALVE :

4.20.1 GENERAL : The item includes supplying and fixing of butterfly valve of specified diameter as mentioned in the schedule.

4.20.2 MATERIAL : The butterfly valve shall be flanged type or as specified conforming to IS 13095 & BS - 5155. The valve shall be bubble tight, resilient sealed suitable for flow in either direction with accompanying flanges and steel handle.

4.20.3 FIXING : The butterfly valve shall be fixed to the pipe line in position as indicated in the drawing and as directed by the Divisional Forest Officer.

4.20.4 TESTING : The valve and the joints shall be tested to a minimum hydraulically pressure of 10kg/sqcm for a duration of two hours or as per testing clause of piping work. The testing shall be done along with the testing of pipe line. The leaky joints shall be rectified to the satisfaction of the Divisional Forest Officer-in- Charge.

5.0 DRAINAGE SYSTEM

5.1 CAST IRON SOIL QUALITY PIPING WORK :

5.1.1 GENERAL The item includes supplying of soil quality CAST IRON pipe of specified diameter with fittings and fixtures including laying, fixing, cutting, jointing and painting the pipe line.

5.1.2 MATERIAL Cast Iron soil quality pipes and fittings shall have ISI certification mark. Sand -Cast, Cast Iron Soil quality or rain water pipes and fittings shall confirm to IS 1729 and centrifugally cast (Spun Cast) cast iron soil quality pipe shall confirm to IS 3989. All the pipes and fittings shall be cylindrical reasonably true with inner and outer surfaces and nearly concentric as practicable. The outer surface of the pipe and fitting shall be finished well, sound, free from pin hole, cracks and other imperfections. The pipes & fittings shall be treated with solution of Dr. Angus Smith’s solution.

The dimensions, weight of Sand-Cast Iron/ Ductile Iron pipes and fittings shall be as per following table of IS 1729 – 2002 or its latest revision.

Tolerance : Mass (-) 5% , thickness (-) –2mm, pipe length (+/-) 20 mm, fitting length (+/-) 10 mm

| Sr. No | Nominal Dia. | Thickness of wall | Nominal weight for pipes of overall length (L) (Exclusive of ears) | | | | | | | | |
|--------|--------------|-------------------|--|-------|-------|-------|-------|-------|------|-------|------|
| | | | 2.0 m | 1.80m | 1.50m | 1.20m | 0.90m | 0.75m | 0.6m | 0.45m | 0.3m |
| | | | kg. | kg. | kg. | kg. | kg. | kg. | kg. | kg. | Kg. |
| 1. | 50 mm | 5 mm | 12.65 | 11.41 | 9.56 | 7.9 | 6.0 | 5.1 | 4.2 | 3.3 | 2.4 |
| 2. | 75 mm | 5 mm | 18.37 | 16.52 | 13.83 | 11.5 | 8.8 | 7.5 | 6.1 | 4.8 | 3.4 |
| 3. | 100 mm | 5 mm | 24.15 | 21.67 | 18.14 | 15.1 | 11.6 | 9.8 | 8.0 | 6.3 | 4.5 |
| 4. | 150mm | 5 mm | 35.66 | 31.92 | 26.70 | 22.6 | 17.3 | 14.7 | 12.1 | 9.5 | 6.9 |

The Dimensions, weight of Spun cast pipes and fittings shall be as per following table of IS 3989 - 1984 or its latest revision.

Tolerances : ((a) Thickness (-)15% (b) Weight (-) 10% (c) Length (+ / -) 20 mm) shall as per IS 3989

| SN | Nominal Dia. | Thickness | Approximate weight for pipes of overall length (L) | | | | |
|----|--------------|-----------|--|------|------|------|------|
| | | | 3.0m | 2.5m | 2.0m | 1.8m | 1.5m |
| | | | kg. | kg. | kg. | kg. | kg. |
| 1. | 50 mm | 3.5 mm | 13.4 | 11.3 | 9.2 | 8.4 | 7.1 |
| 2. | 75 mm | 3.5 mm | 20.0 | 16.8 | 13.8 | 12.5 | 10.6 |
| 3. | 100 mm | 4 mm | 30.0 | 25.5 | 21.0 | 18.8 | 16.0 |
| 4. | 150 mm | 5 mm | 56.0 | 47.0 | 38.5 | 34.9 | 29.5 |

5.1.3 EXAMINING : Before laying the pipe line, it shall be first examined for damages and cracks. No cracked or damaged pipe and fittings shall be used in the work and they shall remove from the site by the contractor at his own cost & charge.

5.1.4 CLEANING : All pipes and fittings shall thoroughly cleaned with brush and washed if necessary

to remove any accumulated stone, soil or dirt inside and out side of piping material.

5.1.5 FIXING : The pipe shall be fixed as shown in the drawing. If the holes are not left in parapet, wall, beam, slab, floor, etc., they shall be cut and cavity surrounding the pipe made good properly after fixing the pipe. The pipe shall be fixed with nails and M.S. clamps having thickness not less than 3 mm , 20 mm wide or as specified in the schedule with socket facing up.

Spacing between clamps for fixing internal piping shall be as per IS 2065 – 1983 as given below :

| Nom. dia of pipe | Horizontal Runs | Vertical Runs |
|------------------|-----------------|---------------|
| 50 mm | 2 M | 2 M |
| 80 & 100 mm | 2.5 M | 2.5 M |

The pipe and fitting shall be kept 50 mm away from the wall face to facilitate cleaning and painting etc. For rain water pipe the inlet end shall be carefully fixed to admit water from roof and shoe shall be fixed at outlet. Cowl shall be fixed at top end of the vent pipe.

5.1.6 LAYING : The pipes shall be carefully laid straight to correct alignment in gradients as indicated in the drawing or as directed by the Divisional Forest Officer. The socket end of the pipe shall be uphill. All the pipes shall be used in standard length as far as possible. Cut length may be used only where it is necessary to make up exact length. While joining, the spigot shall be neatly placed into the socket for full length and properly supported. The entire length of pipe shall be evenly supported on the trench bed through out. Care shall be taken to prevent any sand, earth or other materials from entering into the pipes during laying. At the end of day's work the open end shall suitably plugged.

No pipe shall be laid until the trench has been excavated to its required depth for a distance of about 5 M in front of the pipe to be laid. No pipe shall be covered until it has been passed by the Divisional Forest Officer.

5.1.7 MAKING LEAD JOINT : The spigot shall be carefully centered in the socket by one or more laps of spun hemp yarn twisted into ropes of uniform thickness thoroughly soaked in hot coal-tar or bitumen and cooled before use. The joints shall be made with molten lead and hemp yarn. The lead shall be melted rendering it thoroughly fluid and each joint shall be filled in one pouring. The lead may project 3 mm beyond the face of the socket against the outside of spigot, but must be flushed with the outside edge of the socket.

After the lead has been run into the joint, the lead shall be thoroughly caulked by a suitable caulking tool and 2 Kg hammer and the joint left neat and smooth. The consumption of lead will be worked out on the basis of actual observation at sit. The following table shows consumption of lead and yarn per joint.

| DIAMETER OF PIPE (MM) | YARN (in kg.) | LEAD (in kg.) |
|-----------------------|---------------|----------------|
| 50 | 0.06 | 0.77 |
| 80 | 0.09 | 0.88 |
| 100 | 0.11 | 0.98 |
| 150 | 0.18 | 1.20 |

5.1.8 TESTING : The pipe line which is laid on the ground or below the ground level, the joints shall be tested with two meter head of water from a higher section of pipe line.

The pipe line fixed vertically on the wall shall be tested by the smoke test. The Greasy cotton waste shall be burnt in a smoke machine consisting of bellows and a burner. If any lead joint is found to be sweating or leaking, the contractor shall rectify the same till water tightness is attained to the full satisfaction of the Divisional Forest Officer.

5.1.9 DEWATERING : In case of underground piping, the contract rate shall include bailing or pumping out all the water till completion of work if accumulated during the progress of work either from seepage, springs, rain or any other cause,

5.2 UPVC- SWR PIPING WORK :

5.2.1 GENERAL : The item includes supplying of UPVC soil, waste and rain water (SWR) and ventilation pipes with fittings of specified diameter including laying, fixing, cutting, joining, painting if required etc.

5.2.2 MATERIAL : The pipes shall conforming to IS 13592, UPVC - SWR and fittings conforming to IS 13591 shall be free from cracks, flaws and defects and shall be able to withstand a pressure as mentioned in the schedule of work. Rubber sealing rings conforming to IS 5382 with lubricant for sliding

socket joints as mentioned in the schedule of work.

5.2.3 EXAMINING : Before laying the pipe line, it shall be first examined for damages and cracks, No cracked or damaged pipe and fittings shall be used in the work and they shall be removed from the site by the contractor at his own cost and charge.

5.2.4 CLEANING : All the pipes and fittings shall be thoroughly cleaned with brush and washed if necessary to remove any accumulated stone, soil or dirt inside and out side surfaces.

5.2.5 LAYING : The pipes shall be carefully laid straight to the correct alignment in gradients as indicated in the drawing. All the pipe shall be used in standard length as far as possible. Cut length may be used only where it is necessary to make up exact length. The entire length of pipe shall be evenly supported on bed of the trench through out. Care shall be taken to prevent any sand, earth or other materials from entering into the pipes during laying. At the end of day's work the open end shall be suitably plugged.

5.2.6 FIXING : The pipe line shall be fixed in position as shown in the drawing or as directed by the Divisional Forest Officer. The pipe shall be fixed with G.I. clamps not less than 2.0 mm thick of with suitable UPVC clamps/clips, The clamps/clips shall be fixed into the wall with G.I. nails not less than 40 mm long and wooden gutties keeping the pipe about 15 mm clear of the wall.

5.2.7 MAKING JOINT : The jointing of pipes and fittings generally shall be done with approved make cement solvent including making surface rough or rubber sealing rings with lubricant for sliding socket joints . The pipe shall be cut to desired length. Care shall be taken that that profile or cut surfaces shall not be changed and the fibrous material shall be removed with scraper or knife.

5.2.8 DETACHABLE JOINT : Detachable joints shall be made where pipes of different materials have to be jointed or as specified in the schedule. The flanges are first pushed over the pipe ends and jointing shall be made by cement solvent.

5.2.9 PAINTING : In case of underground piping, the pipe line shall be painted with two coats of approved oil paint of matching colour over a coat of primer.

5.2.10 DEWATERING : In case of underground pipes ,the contract rate shall include bailing or pumping out all the water till completion or work if accumulated during the progress of work either from seepage, springs, rain or any other cause.

5.2.11 TESTING : Please see clause no.5.3.10

5.3 HIGH DENSITY POLYETHYLENE PIPING WORK FOR DRAINAGE:

5.3.1 GENERAL : The item includes supplying of HDPE pipes with fittings of specified diameter including laying, fixing, cutting, jointing.

5.3.2 MATERIAL : The pipes and fittings shall conform to IS 14333. HDPE pipes and fittings shall be free from cracks, flaws and defects and shall be able to withstand a pressure as mentioned in the schedule.

5.3.3 EXAMIN IN G : Before laying the pipe line, if shall be first examined for damages and cracks, No cracked or damaged pipe and fittings shall be used in the work and they shall be removed from the site by the contractor at his own cost and charge.

5.3.4 LAYING : Please refer clause 4.4.03

5.3.5 FIXING : Please refer clause 4.4.05

5.3.6 MAKING JOINT : Please refer clause 4.4.06

5.3.7 DETACHABLE JOINT : Please refer clause 4.4.07

5.3.8 ANTISYPHONAGE : The HDPE pipes shall be used for anti-syphonage including provision, cutting, wastage, bending, dressing, jointing with cement solution, necessary plugs, brass fittings such a brass thimbles, brass union, brass cleaning caps and other brass fittings as required.

5.3.9 DEWATERING : In case of under ground piping works, the contract rate shall include bailing or pumping out all the water till completion of work if accumulated during the progress of work either from seepage, springs, rain or any other cause .

5.3.10 TESTING : The joints shall be tested by either smoke test for vertical stacks or 2.5 m head of water at the highest point of the section under test for horizontal drainage pipes. Smoke shall be pumped into the pipes at the lowest end from a smoke machine which consists of a below and burner .The material usually burnt is greasy cotton waste which gives out a clear pungent smoke which is easily detectable by sight as well as by smell, if there is leak at any point of the drain. The water head test shall be carried out by suitably plugging the lower end of the drain and the ends of the connection if any and filling the system

with water. A knuckle bend shall be temporarily jointed to it so as to provide required test head , or the top may be plugged with a connection to a hose ending in a funnel which could be raised or lowered till the required head is obtained and fixed suitable for observation. The leaky joints shall be remade and section re-tested at no extra cost.

5.4 PVC PIPING WORK :

5.4.1 GENERAL : The item includes supplying of PVC pipes with fittings of specified diameter including laying, fixing, cutting, joining, painting etc. for vent, over flow, waste water pipe line etc.

5.4.2 MATERIAL : The pipes and fittings shall conform to series IV of IS 4985, PVC pipes and fittings shall be free from cracks, flaws and defects and shall be able to withstand a pressure as mentioned in the schedule.

5.4.3 EXAMINING : Before laying the pipe line, it shall be first examined for damages and cracks, No cracked or damaged pipe and fittings shall be used in the work and they shall be removed from the site by the contractor at his own cost and charge.

5.4.4 CLEANING : All the pipes and fittings shall be thoroughly cleaned with brush and washed if necessary to remove any accumulated stone, soil or dirt inside and out side surfaces.

5.4.5 LAYING Please refer clause 4.5.05

5.4.6 FIXING : Please refer clause 4.5.06

5.4.7 MAKING JOINT : . Please refer clause 4.5.07

5.4.8 DETACHABLE JOINT : Detachable joints shall be made where pipes of different materials have to be jointed or as specified in the schedule. The flanges are first pushed over the pipe ends and jointing shall be made by cement solvent.

5.4.9 PAINTING : If mentioned in schedule of work, the pipe line shall be painted with two coats of approved oil paint of matching colour over a coat of primer.

5.4.10 DEWATERING : In case of underground pipes, the contract rate shall include bailing or pumping out all the water till completion or work if accumulated during the progress of work either from seepage, springs, rain or any other cause.

5.4.11 TESTING : The joints shall be tested hydraulically to a pressure as specified in the schedule. The leaky joints shall be remade and section re-tested at no extra cost. The period of test shall be for maximum 2 (two) hours.

5.5 GULLY TRAP :

5.5.1 GENERAL : The item includes provision of S.W. Gully trap with C.I. frame including construction of Gully Trap Chamber.

5.5.2 MATERIAL : The Gully Trap shall be of salt glazed stoneware with 150 mm nominal square inlet or as specified in the schedule with 100mm diameter outlet. Brick work, plastering, concreting shall be as per general specifications under section-II.

5.5.3 CONSTRUCTION :

1. Internal dimension of the Gully trap chamber shall be as specified in the schedule.
2. Foundation of 1:4:8 concrete shall be 150 mm thick, and shall have 100mm offset.
3. Brick masonry shall be of 230 mm thick in cement mortar 1:6 and masonry shall be plastered with 15mm thick plaster in 1:3 cement mortars inside and outside surface with smooth finish.

5.5.4 C.I. FRAME AND COVER : C.I. frame and cover shall be fixed with the cement concrete 1:2:4 at the top of Gully trap chamber, the weight of frame and cover shall not be less than 7.5 kg. and they shall be painted with two coats of black bitumastic paint.

5.5.5 DEWATERING : The contract rate shall include bailing or pumping out all the water till completion or work if accumulated during the progress of work either from seepage, springs, rain or any other cause.

5.6 C.I. NAHANI / FLOOR TRAP:

5.6.1 GENERAL : The item includes supplying of cast iron nahani / floor trap with CP brass/stainless steel grating of specified diameter with fittings and fixtures including fixing and jointing with the pipe line.

5.6.2 MATERIAL : 65 mm nominal outlet dia C I Nahani trap weighing not less than 4.5 kg with an effective water seal of 20 mm or 75mm nom. outlet dia. floor trap (100mm inlet dia.)/ nahani trap (165mm

inlet dia.) conforming to IS 3989 or IS1729 shall be provided as specified in the schedule of quantities. Top grating shall be of CP brass or stainless steel of heavy quality of size and shape to suit the trap.

5.6.03 FIXING : C.I. nahani/ floor trap with the bend and pipe piece shall be fixed in position over the bed of 1:2:4 cement concrete. The jointing trap and pipe shall be caulked with 1:1 cement mortar. The grating shall be fixed over the nahani / floor trap flush with the floor level and the gap finished with matching cement.

5.7 RAIN WATER GRATING :

5.7.1 GENERAL : The item includes supplying of cast iron grating of specified diameter including fixing and painting.

5.7.2 MATERIAL : The rain water grating shall be Cast Iron with closed grained without any casting defects. The thickness should be uniform throughout, one shaped C.I. grating.

5.7.3 FIXING : C.I. rain water grating shall be fixed in position with 1:1 cement mortar.

5.8 LEAD SHEET FLASHING :

5.8.1 GENERAL : The item includes supplying lead sheet flashing of specified size including laying, fixing, cutting, jointing and laying.

5.8.2 MATERIAL : Lead sheet flashing shall not be less than 3 mm thick & weight should not be less than 38 Kg. per sqm.

5.8.3 FIXING : The lead sheet shall be fixed all around the rain water pipe. The sheet shall project one diameter of socket all-round beyond the outer face of the socket & shall project inside the socket at least half the diameter of the rain water pipe socket. It shall be fixed by bending & breaking the sheet to shape, placing, tucking below waterproofing courses etc.

5.9 RAIN WATER G.I. SPOUT :

5.9.1 GENERAL : The item include supplying of G.I. rain water spouts of specified diameter with or without fitting at outlet including fixing. Cutting and painting.

5.9.2 MATERIAL : The rain water spout shall be of heavy quality G.I. pipe of approximate 400 mm length or as specified in the schedule of work. The 'T' of same diameter shall be fixed at the out let of spout. G.I. Pipe and fitting shall be as per specifications under section IV.

5.9.3 FIXING : G.I. rain water spout shall be fixed in the position as shown in the drawing including breaking, cutting RCC pardi, brick wall, RCC floor etc. It shall be fixed with 1:1 cement mortar and 1:2:4 cement concrete.

5.9.4 PAINTING : The exposed part of spout shall be painted with two coats of approved flat oil paint over a coat of primer.

5.10 RAIN WATER C.I. SPOUT :

5.10.1 GENERAL : The item include supplying of C.I. spouts of specified diameter including fixing, cutting, and painting,

5.10.2 MATERIAL : The spout shall be of heavy quality C.I. pipe of approximate 600 mm long or as specified in the schedule of work. Pipe shall be as per specifications of C.I. piping work under Section-V.

5.10.3 FIXING : C.I. rain water spout shall be fixed in the position including breaking, cutting RCC/ brick structure etc. It shall be fixed with 1:1 cement mortar and 1:2:4 cement concrete.

5.10.4 PAINTING : The exposed part of spout shall be painted with two coats of anticorrosive black bitumastic paint over a coat of primer.

5.12 INSPECTION CHAMBER :

5.12.1 GENERAL : The item includes provision of brick masonry Inspection Chamber of internal size as specified in the schedule.

5.12.2 MATERIAL : Concreting, Brick work, plastering etc, shall be as per specification as given in general specification.

5.12.3 CONSTRUCTION :

1. Internal dimensions and initial depth shall be as specified in the schedule or as shown in the drawing.

2. Foundation of 1:2:4 concrete shall be 150 mm thick and shall have 150 mm offset.
3. The concrete 1:2:4 shall be laid to necessary shapes to form the channel for the pipe being received in the channel. It shall be of appropriate diameter and shall be half round. The sides shall be kept sloping towards the channel.
4. Brick masonry shall be 230 mm thick in cement mortar 1:2 or as specified in the schedule of work, making brick tapering for longitudinal wall 450 mm from top of cover of the chamber.
5. Brick masonry shall be rendered with 20 mm thick plaster in cement mortar 1:1 or as specified in the schedule of work inside and outside surfaces in two courses and inside surface finished smooth with neat cement punning.

5.12.4 DEWATERING : The contract rate shall include bailing or pumping out all the water if accumulated during the progress of the work either from rain, seepage, springs or any other cause.

5.13 CIRCULAR MANHOLE :

5.13.1 GENERAL : The item includes provision of brick masonry Circular manhole of internal size as specified in the schedule.

5.13.2 MATERIAL : Concreting, Brick work, plastering etc. shall be as per specification as given in general specification.

5.13.3 CONSTRUCTION :

1. Internal dimensions and initial depth shall be as specified in the schedule of work or as shown in the drawing.
2. Foundation of 1:2:4 concrete shall be 300 mm thick and shall have 300 mm offset.
3. The concrete 1:2:4 shall be laid to necessary shapes to form the channel for the pipe being received in the channel. It shall be of appropriate diameter and shall be half round. The sides shall be kept sloping towards the channel.
4. Brick masonry shall be in cement mortar 1:2 or as specified in the schedule of work. One meter height from top shall be conical in shape and shall be constructed in 230 mm thick brick masonry and remaining height shall be 345mm thick in cylindrical shape.
5. Brick masonry shall be rendered with 20 mm thick plaster in cement mortar 1:1 or as specified in the schedule of work inside and outside surfaces in two courses and inside surface finished smooth with neat cement punning.

5.13.4 DEWATERING : The contract rate shall include bailing or pumping out all the water if accumulated during the progress of the work either from rain, seepage, springs or any other cause.

5.15 DROP CONNECTION :

5.15.1 GENERAL : The item includes provision of drop connection of salt glazed of nominal diameters as specified in schedule of quantities including 1:2:4 cement concrete encased to pipe all round.

5.15.2 MATERIAL : Concreting, mortar for jointing the pipes, hemp yarn, salt glazed stoneware pipes and specials like bends, tees, crosses (double tees), plugs caps etc. of specified diameter shall be of grade 'A' or 'AA' conforming to IS 651. All the pipes and fitting shall be free from pin holes, cracks and other imperfections and should have the glossy finish in salt glazing, necessary form work for encasing the pipe.

5.15.3 DAMAGED MATERIAL : Any material found damaged or cracked shall not be used in the work and contractor has to replace the same from the site at his own cost and charges.

5.15.4 LAYING, FIXING, JOINTING, CLEANING, TESTING : Above shall be done as specified in clause 5.18.00 i.e. salt glazed stone ware piping work.

5.15.5 ENCASING THE PIPE LINE : After the joints and pipes have been proved to be water tight then pipe line shall be embedded in cement concrete as specified in the schedule of quantities and as shown in drawings including necessary form work.

5.15.6 DEWATERING : The contractor rate shall include bailing or pumping out all the water if accumulated during the progress of the work either from rain, seepage, springs or any other cause.

5.17 DROP PIPE CLEANING CHAMBER :

5.17.01 GENERAL : The item includes construction of brick masonry valve chamber of size as specified in this schedule including providing M.S./G.I. frame and cover over R.C.C pre-cast cover with or

without surface box.

5.17.2 MATERIAL : Brick work, plastering, concreting etc. shall be as per general specification . Precast RCC cover slab, surface box, C.I./M.S frame and cover etc. shall be size and weight as specified in the schedule.

5.17.3 CONSTRUCTION :

a) Foundation concrete of mix 1:2:4 shall be of 150 mm thick with 150 mm offset around or as specified in the schedule.

b) Brick masonry in cement mortar 1:2 as specified.

c) Plastering inside and outside surfaces of walls in two courses using cement mortar 1:1 of thickness as specified mixed with water proofing compound of specified Quality including inner surfaces finished smooth with neat cement punning.

5.17.4 RCC PRECAST/CAST IRON COVERS

5.17.4.1 RCC PRECAST COVER (for chambers of size upto 600 x 600 mm) :

Chamber cover shall be casted as shown in the drawing having minimum 75 mm thick in cement concrete 1:2:4 or as specified in the schedule by using nominal reinforcement @ 100 kg/ Cum. of concrete including shuttering, finishing, curing, placing the cover in position as directed by Divisional Forest Officer.

5.17.4.2 CAST IRON/ M.S COVER : Cast iron/ M.S cover of specified size and weight shall be supplied and placed over the chamber as directed. The cover shall be painted with 3 coats of black bitumastic paint.

5.17.05 DEWATERING : The water accumulated in the pit due to rain, seepage, springs or any other cause during the progress of work shall be pumped/bailed out till the completion of work.

5.18 C.I. FRAME AND COVER FOR MANHOLES :

5.18.1 GENERAL : The item includes supply LD/MD/HD/EHD/C.I. frame and cover as specified in schedule including fixing and painting.

5.18.2 MATERIAL : C.I. Frame and cover shall conform to IS 1720 and shall have IS certification mark with grade LD/MD/HD/EHD and the weight of frame and cover shall not be less than as specified in the schedule.

5.18.3 FIXING : Frame shall be fixed in the cement concrete 1:2:4 for bearing course and capping on the brick masonry wall of the chamber of manhole and finishing shall be done in 1:2 cement plaster finished smooth with neat cement.

5.18.4 PAINTING : The frame and cover shall be painted with two coats of approved black bitumastic anticorrosive paint over a coat of primer.

5.19 PRECAST CONCRETE FRAME AND COVER FOR MANHOLES :

5.19.1 GENERAL : The item includes supply LD/ MD/ HD/ EHD factory made precast steel fiber reinforced concrete (SFRC) frame and cover as specified in schedule including fixing and placing.

5.19.2 MATERIAL : The precast frame and cover shall be of steel fiber reinforced concrete (SFRC) conforming to IS 12592 and shall be of approved make. The frame and cover shall be of LD/ MD/ HD/ EHD grade, size and thickness as mentioned in the description of the item. The defective Frame and cover shall be replaced by the contractor at his own cost and charges.

5.19.3 FIXING : Frame shall be fixed in cement concrete 1:2:4 for bearing course & capping on the top of masonry wall of chamber or manhole and finishing shall be done in 1:2 cement plaster finished smooth with neat cement.

5.20 CAST IRON STEPS / RUNGS:

5.20.1 GENERAL : The item includes supplying of cast iron steps including fixing and Painting

5.20.2 MATERIAL : The steps shall be of cast iron and minimum 150 mm wide. The minimum weight of each step shall not be less than 5 kg or as specified in the schedule.

5.20.3 FIXING : The steps shall be fixed in brick masonry wall with 1:2:4 cement concrete with 75 mm cement concrete cover at all around the step. The first step shall be 450 mm below from top surface of structure and next shall be fixed 300 mm centre to centre in two rows at 300 mm distance or as shown in the drawing.

5.20.4 PAINTING : The projected portion of the cast iron step shall be painted with two coats of

approved black bitumastic anti corrosive paint over a coat of primer.

5.20.5 DEWATERING : The contract rate shall include bailing or pumping out all the water if accumulated during the progress of the work either from rain, seepage, springs or any other cause.

5.21 SALT GLAZED STONE WARE PIPING WORK :

5.21.1 GENERAL : The item includes supplying, laying and fixing the salt glazed Stone ware pipes with necessary fittings of specified diameter including laying, jointing etc.

5.21.2 MATERIAL : Salt glazed stoneware pipes and specials of specified diameter shall be of grade "A" or "AA" conforming to IS 651. All the pipes and fitting shall be free from pin holes, cracks and other imperfections and should have the glossy finish of salt glazing.

5.21.3 DAMAGED MATERIAL : Any material found damaged or cracked shall not be used in the work contractor has to replace the same from the site at his own cost and charge.

5.21.4 TRENCHES : The trench shall be so dug that the pipe can be laid to the required alignment and at the required depth. When the pipe line is under road way, a minimum cover of 900 mm is recommended for adoption, but it may be modified to suit local conditions.

Unless otherwise specified by the Divisional Forest Officer, the width at bottom of trenches for different diameters of pipe laid at different depths shall be as given below:-

- a) For all diameters, upto an average depth of 1200 mm , width of trench in mm shall be equal to diameter of pipe plus 300mm.
- b) For all diameters for depths above of 1200 mm , width of trench in mm shall be equal to the diameter of pipe plus 400 mm
- c) Not withstanding (a) & (b) above, the total width of trench shall not be less than 750 mm for depths exceeding 900 mm.

The width of trench in the upper reaches shall be increased as described in sub head under "Earth Work."

5.21.5 LAYING AND FIXING : Pipes shall be laid carefully to the correct alignment, levels and gradient and care shall be taken to prevent for entering the sand, earth or other foreign material into the pipes during laying. The pipes between manhole shall be laid truly in straight line, without vertical or horizontal undulations.

All inverts shall be laid from sight rails fixed at the true levels, with proper boning rods, The pipes shall be laid sockets facing up the gradient, alignment at the lower end and with the socket resting in the concrete bed if specified. Each pipes shall be laid singly and no pipe shall be laid until the trench has been excavated up to the required depth for a distance of 5meter in front of the pipes to be laid.

5.21.6 JOINTING : Spun yarn soaked in cement wash shall be passed round the spigot and spigot inserted in the socket, The spun yarn shall then be caulked with 1:1 cement mortar with a little water, pressed into the joint with hand and finished at 45 degree The mortar shall be cured for seven days.

The following table shows the details of materials used for jointing the S.W. pipe.

| Internal dia of pipe (mm) | Depth of socket in mm | Depth of yarn in mm | Depth of C.M. paste in mm |
|---------------------------|-----------------------|---------------------|---------------------------|
| 100 | 50 | 20 | 33 |
| 150 | 56 | 30 | 30 |
| 230 | 65 | 30 | 35 |

5.21.7 CLEANING : Interior surface of the pipes and fittings shall be cleaned off from all dirt, cement mortar and superfluous materials.

5.21.8 TESTING : The joints of S.W. Pipe line shall be tested for a minimum 600 mm water head over the crown of the highest pipe between the two manholes. The lower end shall be plugged water tight. Water shall then be filled in the inspection chamber or manhole at the upper end of the line with 600 mm depth of water over the crown. If it is found the certain pipe joints are leaking, the water shall be drained off and joints shall be recaulked.

5.21.9 ENCASING THE PIPE LINE : After the joints and pipes have been proved to be water tight then pipe line shall be embedded in cement concrete if specified to the extent of one half of external diameter of the pipes as directed, the concrete being made to slope away towards the sides of the foundations bed. Refilling shall be done with fine selected materials and shall be done in layers not exceeding 150mm thick, watered, consolidated and rammed properly, as specified.

5.21.10 DEWATERING : The contract rate shall include bailing or pumping out all the water if accumulated during the progress of the work either from rain, seepage, springs or any other cause.

5.22 SEWER TRAP :

5.22.1 GENERAL : The item includes supplying, laying and fixing the Stone ware sewer trap of specified diameter including fixing, jointing and embedding.

5.22.2 MATERIAL : Sewer trap shall be salt glazed of stoneware of specified diameter and shall be of grade "A" or "AA" conforming to IS 651. Sewer trap should be free from pin holes, cracks and other imperfections and should have the glossy finish of salt glazing.

5.22.3 DAMAGED MATERIAL : Any material found damaged or cracked shall not be used in the work and contractor has to replace the same from the site at his own cost and charge.

5.22.4 FIXING : Sewer trap shall be laid carefully to the correct alignment, levels and gradient and care shall be taken to prevent for entering the sand, earth or other free material into the trap during laying. The trap shall be on bedded in CC 1:2:4 including necessary form work.

5.22.5 TESTING : The testing shall be done along the testing of sewer line with the same specification.

5.22.6 DEWATERING : The contract rate shall include bailing or pumping out all the water if accumulated during the progress of the work either from rain, seepage, springs or any other cause.

5.23 CONNECTION WITH DOMESTIC SEWER :

5.23.1 GENERAL : The item includes the provisions of connecting sewer line with existing sewer line chamber or manhole including cutting, breaking of masonry, road surface and making good to the original condition of the damages.

5.23.2 MATERIAL : Concreting, Brick work, plastering etc. shall be as per specification as given in general specification of section II.

5.23.3 MAKING CONNECTION :

1. Breaking or cutting the road surface for sewer connection.
2. Restoring all the excavated items in proper manner as directed by the Divisional Forest Officer
3. Cutting the brick masonry wall to required size of existing manhole or inspection chamber.
4. Connecting the sewer line to the chamber or manhole.
5. Making good to the original condition all the damages after completion of sewer connection.
6. Disposing off all the superfluous material as directed.

5.23.4 DEWATERING : The contract rate shall include bailing or pumping out all the water if accumulated during the progress of the work either from rain, seepage, springs or any other cause.

5.24 CONNECTION WITH MUNICIPAL SEWER LINE :

5.24.1 GENERAL : The item includes the provisions of connecting sewer line with existing municipal sewer line chamber or manhole including cutting, breaking of masonry, road surface and making good to the original condition of the damages.

5.24.2 MATERIAL : Concreting, brick work, plastering etc. shall be as per specification as given in general specification .

5.24.3 MAKING CONNECTION :

1. Breaking or cutting the road surface for sewer connection.
2. Restoring all the excavated items in proper manner as directed by the Divisional Forest Officer.
3. Cutting the brick masonry wall to required size of municipal manhole or inspection chamber.
4. Connecting the sewer line to the chamber or manhole of Municipal sewer line.
5. Making good to the original condition all the damages after completion of sewer connection.
6. Disposing off all the superfluous materials as directed.
7. All necessary labour, materials and use of tools.

5.24.4 DEWATERING : The contract rate shall include bailing or pumping out all the water if accumulated during the progress of the work either from rain, seepage, springs or any other cause.

5.24.5 MUNICIPAL CHARGES : The contractor shall obtain the necessary permission for connecting

the sewer line to the municipal sewer from the concerned authorities. He shall pay all necessary charges towards the connection given by the municipality.

6.0 WATER TANK, SEPTIC TANK, UPFLOW FILTER & SOAK PIT

6.1 FRAME AND COVER :

6.1.1 GENERAL : The item includes supplying of M.S. or C.I. frame with cover of size as specified in the schedule including fixing and painting. The frame and cover shall be of mosquito proof condition and approved by the Municipality

6.1.2 MATERIAL : The frame and cover shall be of mild steel or cast iron as specified in the schedule. The weight of frame and cover shall not be less than 50 kilogram's. They should have locking arrangement.

6.1.3 FIXING : The frame shall be fixed in the roof slab of tank or built with hold fast to R.C.C. slab by chasing or cutting slab and grouting with 1:2 cement mortar.

6.1.4 PAINTING : The frame and cover shall be painted with two coats of approved anti corrosive black bitumastic paint over a coat of approved quality primer.

6.4 BALL VALVE :

6.4.1 GENERAL : The item includes providing horizontal type ball valve with PVC or copper float of size as mentioned in the schedule including fixing.

6.4.2 MATERIAL : Horizontal plunger type ball valve with PVC or copper float shall be conforming to IS 1703. The lever shall be of brass and may be made in one piece and the diameter of the lever rod shall not be less than the diameter of the thread for boss of ball. Float shall be watertight and non-absorbent and shall not contaminate water. Adhesives for joining the part shall not be used. The minimum thickness for copper sheet of copper float shall be 0.45 mm up to 115 mm diameter and 0.55 mm for ball over 115 mm diameter. Valve shall be tested in closed position to the hydraulic pressure of 2 MPa for a minimum period of 2 minutes without leakage and sweating.

6.4.3 MINIMUM MASS : The minimum mass of finished ball valve and float of different size and class shall be as per Table No. 8 of IS 1703.

6.4.4 FIXING : Valve shall be fixed in position as indicated in the drawing with necessary socket, union nuts etc. as per site requirements. A few turns of fine hemp yarn dipped in linseed oil shall be taken over the threaded ends to obtain complete water tight joint. Leaking joint if any shall be rectified to make it leak proof.

6.4.5 TESTING : Testing shall be done along with the testing of pipe line, Separate testing if required shall be done as per ISI norms.

6.6 POLYETHYLENE WATER TANK :

6.6.1 GENERAL : The item includes providing polyethylene plastic water tank with cover of capacity as mentioned in the schedule including fixing and making connections such as inlet, outlet, scour, overflow etc.

6.6.2 MATERIAL : The water tank shall be made out of best moulded Polyethylene plastic. It shall be vertical or horizontal type as specified, watertight and non-absorbent and shall not contaminate water. Adhesives shall not be used in joints. The cover shall be of polyethylene / M.S. / C.I. as approved.

6.6.3 FIXING : The plastic water tank with cover shall be installed and fixed as per the manufacturer's specification. The connections such as inlet, outlets, over flow, scour etc. of specified diameter shall be made as mentioned in the schedule including the cost of fittings, fixtures and pipe of approximate 400 mm long.

6.8 GENERAL SPECIFICATIONS FOR WATER TANK AND SEPTIC TANK :

6.8.1 GENERAL : Construction of water tank, septic tank and up flow filter is required to be done very carefully with good quality materials. Dense, well compacted concrete of required strength has to be achieved in order to make water tight compartment. The slope in the bed of tank, invert levels of insert, and also the levels of partition and baffle walls should be properly maintained for proper flow of liquid.

6.8.2 TESTING OF WATER TANK AND SEPTIC TANK : After construction of tank, it shall be tested for leak proof ness. The tank shall be first filled with water up to the top of wall. The water level should not drop more than 50 mm within 48 hours. If the drop of water level is found more than 50 mm the defective

and leakage point shall be rectified to the full satisfaction of the Divisional Forest Officer.

6.8.3 COMMISSIONING OF SEPTIC TANK : Before commissioning the septic tank, a little quantity of digested sludge, horse or cow dung may be added as a seed sludge to start functioning of bacterial activity in sewage.

6.8.4 BACK FILLING : The back filling shall be done as per specification after satisfactory testing of the tanks. Back filling shall be done in layers all around the tank and above the roof slab of the tank up to the height / depth as directed by the Divisional Forest Officer.

6.8.5 CLEANING OF WATER TANK : The cleaning of the tank shall be done by manually or by Hydro dynamic mechanism with low or high pressure as directed. Potable water, approved disinfectant etc. shall be used for cleaning of water tank before use.

6.8.6 DEWATERING : The contract rate shall include bailing or pumping out all the water if any accumulated during the progress of work either from rain, seepage, springs or any other cause till completion of the work.

6.9 HUME PIPE SEPTIC TANK:

6.9.1 GENERAL : The item pertains to providing Hume pipe septic tank of specified diameter with vent pipe and cap including laying, fixing and making connections.

6.9.2 MATERIAL : The Hume pipe septic tank of specified diameter and capacity with vent pipe and cap. The Hume-pipe septic tank shall be in good condition without any damage and cracks.

6.9.3 LAYING AND FIXING : Hume pipe septic tank shall be fixed in position and level as indicated in the drawing as per the manufacturer’s specifications. The pipe joints for connection shall be made in cement mortar 1:1 The vent pipe with cap shall be fixed to the septic tank. Septic tank shall be completely filled with water just before putting into use.

6.9.4 DEWATERING : The contract rate includes bailing or pumping out all the water if accumulated during the progress of work either from rain, seepage, springs or any other cause till completion of the work.

6.10 SOAK PIT :

6.10.1 GENERAL : The item pertains to providing Soak pit of specified size as mentioned in the schedule of quantities including filling with brick bats and coarse sand filling around the honey comb brick wall.

6.10.2 MATERIAL : The brick bats shall be from properly burnt bricks and not from over burnt bricks, Coarse sand filling. Brick work and plastering shall be as per general specifications .

6.10.3 CONSTRUCTION : Brick masonry shall be in cement mortar and its size and type shall be as specified in the schedule. The pit shall be filled with loosely packed brick bats. The coarse sand shall be filled around the honey comb brick wall of specified thickness.

6.10.4 DEWATERING : The contract rate includes bailing or pumping out all the water. If accumulated during the progress of work either from rain, seepage, springs or any other cause till completion of the work.

| | | |
|----|-------------------------------|--|
| 1 | CPVC Pipes | Ashirvad / Astral / Ajay |
| 2 | Sanitary ware | ROCA / Hindware / Parry ware |
| 2a | Wash Basin - Corian | Mojo / Roca |
| 3 | Toilet Accessories | Bobrick / Toto |
| 4 | CP fittings | Kohler/Roca/American Standard |
| 5 | Gate valves/Non-return Valves | Audco/L & T /RB/Leader /Legris |
| 6 | Submersible Pumps | Lubi/Darling. |
| 7 | Liquid level controllers | Sridhan International / Filpro electronics |
| 8 | Kitchen sink | Frankee / Jayna |
| 9 | UPVC pipes & fittings | Finolex / Supreme |
| 10 | Pipe protection tape | Tapex |
| 11 | Concealed / Buried | Pipe coat |
| 12 | Hot water insulation | Vidoflex / Armaflex |
| 13 | Butterfly valve | Audco/L &T/Saunders |

| | | |
|----|--|--|
| 14 | Urinal flushing sensor | Kohler/Roca/American Standard |
| 15 | Soap dispenser | Bobrick |
| 16 | Hand Dryer | Bobrick |
| 17 | Water Heater | AO Smith |
| 18 | UPVC pressure pipes (schedule 40) & fittings | Astral/ Supreme/Ajay |
| 19 | Ball Valve | Leader /RB |
| 20 | Water meters | Shenitech / Forbes Marshall |
| 21 | GRP Tank | Devi polymers |
| 22 | Dosing pumps | Grundfos / Asia LMI |
| 23 | Cast Iron Hubless pipe | Neco /Saintgobain |
| 24 | Floor trap frame & grating | Neer (Material :SS) |
| 25 | Manhole frame & cover | Crescent Foundry / ACO / Neco |
| 26 | Water hammer arrester | CPP / Zum Wilkins |
| 27 | RCC Hume pipes | Indian Hume pipes/RBBR |
| 28 | Y-strainer | Leader / equivalent |
| 29 | C I Class pipes & Fittings | Saint Gobain/ Neco |
| 30 | Grease Separator , Kitchen drainage Gratings | ACO/Claire Fontaine |
| 31 | HDPE pipe and Fittings | Supreme |
| 32 | Flow Restrictor | Neoperl |
| 33 | PRV | Singer |
| 34 | Foot valves | Leader / Legris |
| 35 | Filters | Ion exchange / Thermax / approved make |
| 36 | Dosing Units | Asia LMI/Approved |
| 37 | RO Membrane | INGE |
| 38 | Heat Pump | Energen/AO smith/ |
| 39 | Solar collectors | Energen/AO Smith |
| 40 | Hot water tank | Energen/AO smith |
| 41 | Pump station | Resol/Caleffi |
| 42 | Expansion tank | Baymak/Caleffi/zilmate |
| 43 | Butterfly valve | Audco |
| 44 | Copper Pipes | Rajco |
| 45 | Hot water circulation pump | Grundfos/Wilo |
| 46 | G.I pipes | Tata / Jindal hissar |
| 47 | sensors | 'Resol/Caleffi |
| 48 | Insulation | Vidoflex / Armaflex |
| 49 | Hot water control panel | Century / Resol |

TECHNICAL SPECIFICATION OF INTERNAL ELECTRIFICATION WORKS

Scope of Work

The scope, among others, includes the following,

- Source of power supply
- HV Distribution
- LT Distribution
- Emergency Power supply system
- Uninterrupted power supply system
- Internal electrification
- Earthing
- Lightning & Surge Protect

Source of power supply

Source of power supply is from TPCODL. The Maximum power demand for proposed office to be calculated and provided as per approved drawings.

HV Distribution

- Fault level considered. Calculations for fault level for various stages.
- Indoor or Outdoor – Specify type & Protection clause.
- Provide local control near Outdoor or Indoor receiving point of supply.
- HT Panels shall be of VCB upto 33KV & SF6 above 33KV.
- Underground HT cable shall be XLPE insulated.
- End terminations shall be Heat shrinkable.
- Earthing conductors are Hot Dip G.I. Calculation for earth conductors for fault level for main grid, sub-grid, etc.
- Earth electrodes as per IS 3043.

LT Distribution

- LT Power panels shall be as close as possible to load centres. It shall be supplied from an authorized vendor as per the approved makes.
- It shall be segregated into two units in such a way that any one can be taken for preventive maintenance with Office in running condition. The output shall be selected to achieve this for e.g. if 2# of feeders required for Air conditioners can be taken from each panel to achieve the continuity of essential activities.
- All panels shall be equipped with ACB/ MCCB of adequate KA rating. MCCB to be restricted upto 630A rating. For rating above 630 Amp, ACB shall be used. ACB shall be of drawout type for incomers.
- All MCCB/ ACB controlling the input power supply shall be of Electronic/ Microprocessor based with site tunable O/C, E/F, release. Rating less than 250A shall be with thermo magnetic releases.
- All major loads like Air Conditioners, etc shall have independent feeder.
- XLPE Al armoured cable shall be used for power distribution. Aluminium flats/ copper cables shall be used for internal connection in LTPanels.
- Entire installation shall have G.I. ladder type cable trays with supporting system. Suitable GI covers to be provided as mechanical shielding wherever required to avoid damage to cables.
- Earthing conductor to be laid for the entire system to achieve earth resistance not more than 4 Ohm for GI and less than 1Ohm for copper.

- Automatic P.F. Control with panel with auto / manual selector switch shall be provided in the main substation to maintain minimum P.F. of 0.98. It shall be have built-in reactive power compensation filters to contain the Harmonic less than 5%.
- DG set and the LT panels shall have provision for auto change over in the event of power failure.
- All safety components like surge Arresters, Electrical and mechanical interlock system, indicating lamp, relays, digital meters, potential & current transformers, power pack, protective devices, etc. shall be built in & acceptable to the user.

Emergency Power supply system

As per NFPA, installation shall be divided into Emergency, Essential, and Critical circuits. As per NEC of India 2011 also, the installation shall have Standby, Safety supply and Extra Safety supply system. The entire power supply is planned to be backed up with DG sets, Essential and Emergency systems are taken care. For Life safety equipment which need less than 10secs interruption, UPS supply is suggested. For Critical branch circuits like Lighting etc, separate Lighting UPS/ Inverter is suggested..

Emergency power supply to be planned with Diesel Generator sets for 100% backup.

Uninterrupted power supply system

UPS power to be provided for all critical areas like Control Rooms, Conference rooms etc. as per specified norms.

Internal Electrification

The internal wiring shall be done in recess with stranded copper conductor drawn through heavy guage PVC conduit. MS conduit shall be used in case of surface conduit wiring. Modular switch and sockets shall be used mount on GI boxes.

The details of internal wiring, the position of fittings, fans, switches and plug sockets etc. are indicated in the layout drawings. The position of light fittings, fans, switchboards etc. indicated n these drawings are only for the guidance of the supplier and the actual position of these shall be mutually decided between the supplier and the purchaser. The supplier shall submit the purchaser of his consideration and approval all runs of wiring and the exact position of all the points and the switch boxes first marked on the points buildings.

All internal wiring shall be done in conformity to the latest Indian standard specification/Rules, code of practice adopted by CPWD and other standard practices prevalent in the part of the country. For the purpose of the specification the terminology used shall be as defined in IS:732 and IS:1356 of the definition of points wiring. The installation shall be carried out in conformity to all requirements of IE Act, 1910 and IE Rules 1956.

- a) Ceiling rose in (in case of ceiling and exhaust fan).
- b) Ceiling rose or connector (in case of pendants except stiff pendant points)
- c) Bank plate (in case of stiff pendant).
- d) Socket outlet (in case of socket outlet points)
- e) Lamps holder (in case of wall Bracket, batten holder bulk head fitting and similar other fittings)
- f) Call bell / buzzer (in case words 'via' the switch shall be read 'via' the ceiling rose / socket outlet for bell push, where no ceiling rose / socket outlet its provided.

The following shall be deemed to be included in the point wiring

- a) Switch and ceiling rose are required.
- b) In case of wall brackets, bulk head fittings, cables as required up to the lamp holders]
- c) Bushed conduit for porcelain tubing where cables pass through walls.

- d) All wood or metal blocks, boards and boxes, R.J. Boxes sunks or surface type including those required for fan regulator but excluding those under the distribution board and main control switch.
- e) Earth wire from 3 pin socket point to the common earth including connection to the earth dolley.
- f) Earth wire of 16SWG/14 SWG/I.G. wire for loop earthing of the fixture.
- g) All fixing accessories such as clips, nails, screw, plug, rawl plug, wooden plug, round blocks etc. as required.
- h) Joint for junction boxes and connecting the same as required.
- i) Connections to ceiling rose or connection socket outlet, lamp holders, switch, fan regulators etc.

The point wiring in case of fan and light points shall mean the distance between the control switch and ceiling rose, connect or back plate, socket outlet or lamp holder depending upon the fittings measured along the runs of wiring irrespective of the number of wires in run. In the case of socket outlet points, the length shall mean the distance between the socket outlet and the tapping point of live wire on the nearest switchboard or junction box, as the case may be.

In the case of exclusive socket outlet circuits wired on 'Joint Box' system of wiring, any junction provided for extending the wiring beyond the point referred to, shall be treated as the nearest tapping point. In case of call bell / buzzer points the length shall mean the distance between the call bell and the ceiling rose / socket outlet or the bell push (when the ceiling rose / socket outlet is not used).

Sub main shall include the earth wire of adequate size main distribution Board up to sub distribution board B.B. such wiring has been classified on the basis of length. For the internal lighting, either surface conduct wiring system or recessed conduit or batten wiring system shall be provided as specific in the bill of quantities and working drawings. **(The above portion is not relevant in this and may be removed)**

Conduit wiring

For recessed conduit wiring system the conduit shall be placed in the ceiling / columns etc. before the casting of the slab or column. The conduit pipes shall be properly positioned and fixed so that it will not be displaced at the time of concreting. The junction boxes provided shall be so arranged that its cover will be flushed with the finished surface of the ceiling or column.

For placing the conduits in the walls, chases of ample dimension shall be made neatly to fix the conduit in a desired manner. The conduit pipe shall be fixed by means of staple or saddles not more than 600mm apart. Fixing of standard bends or elbows shall be avoided and all curves maintained by bending the conduit itself with a long radius will permit easy drawing of the conductors. Suitable inspection boxes shall be provided to permit periodical inspection and removal or replacement of wires if necessary. There shall be mounted flush with the wall with holes in the cover of the box.

The switch or regulator box shall be made of metal on all sides except on the front where backlight sheet or Perspex cover painted to match the colours of the wall shall be used I case of surface wiring system. For recessed wiring system, these boxes shall be made flush with the conduit of each conduit or section shall be completed before conductors are drawn in. **(The portion marked red may be removed)** The entire system of conduit after installation shall be tested or mechanical strength and electrical continuity throughout the earthing of the entire installation shall be carried out in accordance with I.E. Rules and standards. The number of wires drawn in the conduits shall not exceed the numbers those specified in Indian standard specification No.732.

Earthing

Earthing shall generally be carried out in accordance with the requirements of Indian Electricity Rules and the relevant rules and regulations of electrical supply authorities. The complete earthing work for the installation covered by this specifications shall also be provided taking into account Indian Standard Specification No.IS:732 and IS:3043. The earthing system adopted shall also have adequate mechanical strength.

The work shall include earthing of noncurrent carrying metallic parts of all the equipment, light fittings, conduit pipes, cable and cable supports and earth strips (the design to be approved by the purchaser) and all the inter connection between the earthing system to a value mutually agreed upon\ between the purchasers and the supplier.

Lightning & Surge Protect

Lighting Protection:

- Lightning Protection is planned based on IS 2309 using Conventional type Air Finals and connected with Copper plate earth stations in Ground in the open area.
- Earth Resistance value shall be less than 10 Ohm
- All horizontal air terminations shall be interconnected such that no part of the roof is more than 5 m away from the nearest horizontal conductor.
- Every down conductor is proposed to be connected to a separate earth station
- All Earth stations are proposed to be interconnected as a Equi potential bar

Surge Protection:

The switching surges due to start of major Motors can create switching surges, other than Lightning Surges. These switching surges shall be arrested at the main Panel and also near critical equipment. The expensive equipment like MRI/CT Scan/ Cathlab are proposed to be protected against Voltage/ Current surges. The Insulation requirements of various Electrical equipment ie 415V/ 240V are specified by IEC 60364-4.

Surge Protection devices are proposed at all following locations

- Main PCC
- Distribution Boards feeding Criticalloads

Installation, testing and Commissioning:

The supplier shall be responsible for the installation testing the commissioning of all the equipment and materials supplied by him against this specification. This shall also include the provision of miscellaneous wiring and supports and earthing in compliance with Indian Electricity rules and to the full satisfaction of the Government Electrical Inspector. All small items such as clamps, bolts, nuts, racks, supports, miscellaneous wiring etc. required to make the installation complete, shall constitute the part of major items specified in the bill of quantities and the tenderer should quote for each item taking these into consideration.

The responsibility of the supplier shall include receiving all the equipment and materials at site, storage for required period, handling the same at the site of erection, final execution , erections, revisions of equipment, if any, testing and commissioning and handing over the installation complete in all respect to the entire satisfaction of the purchaser's authorized representative. The supplier shall make good of all the damaged equipment and materials during this period at his own expense. The supplier shall submit sample of each and every equipment and materials for the final approval of the purchaser's representatives immediately after the acceptance of offer. All the equipments and materials shall be supplied exactly as per to the approved samples. If at any stage the purchaser brings to the notice of the supplier any discrepancy or defect the supplier shall replace the same at his own expense.

The supplier shall render all reasonable assistance to the purchaser in getting the installation approved by the Government Electrical Inspector prior to the energisation and supply necessary drawings, test certificates and both for tests carried out at the factory and site as well as the tests which the inspector may demand. In case any addition of alternations are required, to be made in the

installation or in the equipment as per the directive of the Government Electrical Inspector / Local Authorities, the same will have to be carried out by the supplier, at his own expense.

The position of light fittings, main board, switches, sockets and routes of pipes and cables shown in the drawings are only indicative. The actual position of these shall be decided at site at the time of execution jointly by the supplier and the purchaser's authorized representative. The position of light fittings, pipes and board if required, to be changed / shifted due to the change in the building design etc by the purchaser's authorized representative, the same shall be carried out at no extra cost.

All the materials supplied to the contractor according to the Contract condition will be subject to inspection and approval of the officer or his representative from time to time. The contractor will provide all facilities of such inspections free of cost. At the time of inspection, the owner or his representative will have full liberty to reject any such materials, which does not conform to the specification / requirement. No claim for any rejected materials will be entertained by the owner. The contractor will remove all rejected materials from site at his own cost. No surplus materials procured by the contractor will be accepted by the owner. The contractor will be responsible to get the Electric installations cleared by the Electrical Inspector of Odisha Government. Only the inspection fee will be reimbursed by Department on production of challan copy.

Installation and Maintenance Tools:

The supplier along with the tender shall furnish a complete list of tools, appliances and accessories required for the installations of switch gear, light fittings, pipes cables and wires.

Drawings:

All drawings, test certificates, instructions manuals etc. shall be in English Language and all dimensions and weights shall be in metric units.

The tenderer shall submit with the tender general arrangement drawings for the installations work, typical methods and cabling and cables supports pipe work and pipe supports, typical methods of earthing and fixing of light fittings earthing etc. as offered by him in the tender.

The contractor shall submit for the purchaser's approval all layout, the general arrangement drawings as well as the typical details of all types of installation work in three sets before commencing the manufacture and the site installations work well in advance so that the site work shall not suffer.

After obtaining approval of the above drawings the contractor shall supply three sets of the following drawings:

- (a) The arrangement and support of conduit pipe.
- (b) The position of light fittings, switches / plug socket and switch boards
- (c) Earthing installations
- (d) Layout plan showing the entire cable network

On completion of work, the successful tenderer shall supply one set of tracing in transparent linen and five sets of prints of all drawings incorporating all the changes / modifications affected during the execution of the contract. All wiring diagrams shall indicate clearly, the switch board, the runs of main and sub main wiring and the position of all the points with their controls. All the circuits shall be clearly indicated and numbered in accordance with IS:375. The technical literatures and operating instructions and the maintenance manuals shall also be supplied in triplicate to the purchasers after the completion of the installations work.

Test:

Manufactures standard tests in accordance with Indian Standard and other standards, adopted shall be carried out on all the equipment and accessories covered by this specification so as to ensure efficient and satisfactory performances of all the components and also the equipment as a whole under working conditions at site. The tenderer shall submit a complete list of all such tests. If the purchaser, if so desired for special tests, to be carried out, under certain conditions the same shall be made by the successful tenderer at his own expenses. All equipment shall be tested at site before the commissioning in accordance with the adopted standard and Indian Electricity Rules. Voltage test shall be carried out on each circuit on completion of wiring and cabling.

Technical Data:

The tenderers shall submit with their tender all such technical data, which are required for complete evaluation of the equipment offered. The suppliers shall give complete technical information of the equipment as detailed in Annexure and relevant Indian standards. The tenderer should supply such details of all equipment and materials offered specially with regard to the following.

- a) Fuse switch board and distribution boards
- b) Light fittings
- c) Conduits and the accessories for them
- d) Switches / plug sockets
- e) Cable and wires

The tender shall give along with his tender the following details:

- a) Complete details of earthing electrodes, earthing station and earthing conductors
- b) Details of conduit supports
- c) Details of all the equipment and accessories to be supplied

Exception to Specifications:

The object of this specification is to have all tenderers quote for equivalent materials and workmanship. It is, however, understood that certain manufacturers may not be able to offer as specified in every case, where the tenderer may find it necessary to deviate from the exact letter and not the intent of the specification, he must specifically state what these deviations may be at the time he submits the tender. All deviations must be grouped in one statement. No deviations other than those included in the tender will be permitted.

PVC insulated Cables and Wires:

For 415V Distribution system, cables of voltage grade not less than 1000V shall be used. These cables shall be heavy-duty class, PVC insulated and PVC sheathed with aluminium/ copper conductors. PVC insulated FRLS copper wire shall be used for point, circuit and submain wiring including wiring for power outlets. Wires of different colours shall be made use of for quick identification of phase wire / neutral wire etc. All cable of wires shall comply with the requirements regarding the manufacture and testing etc as specified in India Standard Specification IS: 1554 and IS:694.

The length of cables indicated in the bill of quantities and drawings are only indicative and the Successful tenderer will be paid for the exact length of cables laid at site. No joint shall be allowed in a run of cables, which can be covered by a possible drum length of cables.

Fuse switch / switch fuse shall be metalclad dust and vermin proof suitable for use under climatic conditions prevailing at site. Switch fuse / fuse switch units shall comply in general to IS:1567/4064 with regard to design and constructional / features.

The 'ON' and 'OFF' position of the switch handles shall be distinctly indicated and interlocks shall be provided to ensure that the switch cover cannot be opened unless the switch is in the 'OFF' position. Means shall, however, be provided for releasing the interlock to permit closing of switch with cover open for testing purposes. Designs with normal conventional position of switch handles, i.e. with switch handle up in the 'ON' position and down in the 'OFF' position shall be preferred. All live parts inside the switch shall be properly surrounded and inter phase barrier shall be provided.

Switch fuse / fuse switch units, distribution boards shall be provided with necessary metal frame work so that they can be mounted on wall / columns structure etc. as desired. The panel boards, shall be wall mounted type or floor mounted type as specified in the bill of quantities or drawings. Necessary supporting metal frame of approved design shall be provided for all panel boards

The arrangements of work boards shall be such that the operational handle of the top mounted switches are within the convenient of operators (about 1.2 M from the finished floor level) and proper space shall be provided for the termination of the cable in the switches provided below the bus-bars.

The bus-bars within the bus-bar chamber shall be liberally spaced for taking the riser connection. The bus bars with aluminium conductors shall be provided and PVC sleeves of different colour shall be mounted on them for easy identification, Clamped joints for taking the riser connections, instead of bolted type shall be preferred.

Two bolted type earthing terminals shall be provided on the switch boards. All individual switches shall be connected with suitable size earth wire to the main earthing terminals of the switchboard. Hanger Board and shock treatment / charts shall be supplied wherever required. At the incoming side of each pen phase, 3-neon type indicating lamps should be provided at the main board.

Switches and Plug Sockets

Switches provided for control of light points shall conform to IS:1087 and shall be rated for 5A/15A 250V.

Ceiling Fans and Exhaust Fans:

Ceiling fans shall conform to Indian standard specification IS: 374-1960. The fans shall be supplied with all standard accessories like regulator and capacitors etc. Ceiling fans shall be 5 star rated.

The performances rating of the propeller fans shall in accordance with stipulations of IS:2312. All fans shall be robust in design and construction and shall be supplied complete with wall brackets / clamps etc.

LUMINAIRES & LAMPS

Luminaires and lamps shall be of reputed make. The type of luminaires shall be as specified in the BOQ. The lamps shall be of the high efficiency type.

Lighting fixtures and accessories shall be designed for continuous trouble free operation under diversified atmospheric conditions without deterioration of materials. Degree of protection of enclosure shall be IP-65 for outdoor fixtures. Bulkhead fixture shall be provided with IP-54 protection and all internal lighting fixtures shall be IP20.

Fixtures shall be so designed as to facilitate easy maintenance including cleaning, replacement of lamps / ballasts.

All fixtures shall be supplied complete with lamps and accessories, like electronic ballasts, power factor improvement capacitors, etc. Out door type fixtures shall be provided with weather proof terminal and control gear housing with IP-54 protection.

Each fixture shall have a terminal block suitable for loop-out connection by 1100 V PVC insulated copper conductor wires up to 2.5 sq.mm. Fixtures shall be pre-wired.

All hardwares used in the fixtures shall be suitably treated against corrosion

Earthing: Each lighting fixtures shall be provided with an earthing terminal. All metal parts shall be bonded to earth.

Metal used in BODY of lighting fixtures shall be not less than 22 SWG to comply with specification. Sheet steel reflectors shall have a thickness of not less than 20 SWG. The metal parts of the fixtures shall be completely free from burrs and tool marks.

Painting/Finish: All surfaces of the fixtures shall be thoroughly cleaned treated and degreased before painting.

The housing shall be powder coated/stove-enameled or anodized as required. The surface shall be scratch resistant.

Reflectors shall be made of CRCA sheet steel/aluminium /Silvered glass/Chromium plated copper sheet as asked for. The thickness of reflectors shall be as per relevant standards. Reflectors made of steel shall have stove enamelled/ vitreous enamelled/epoxy coating finish. Aluminium used for reflectors shall be anodised/epoxy stove enamelled /mirror polished. The finish for the reflector shall be as specified. The reflectors shall be free from scratches and shall have a smooth and glossy surface having optimum light reflecting coefficient. Reflectors shall be easily removable from the housing for cleaning and maintenance without use of tools.

LED (Light Emitting Diode) Light Fittings:-

LED's are small semiconductor components that convert electrical current into visible light. LED's are used as a light source after many benefits as follows

- Compact in size.
- High Luminous Intensity.
- Saturated vibrant colors.
- Fully Dimmable from 0% to 100%.
- Instead On/Off no accelerated again due to switching cycles.
- Long life time.
- No direct IR or UV emission.
- Mechanically robust shock and vibration proof.

LED's are based on the semiconductor diode. When the diode is forward biased (switched on), electrons are able to recombine with holes and energy is released in the form of light. This effect is called electroluminescence and the color of the light is determined by the energy gap of the semiconductor. The LED is usually small in area (less than 1 mm²) with integrated optical components to shape its radiation pattern and assist in reflection.

ELECTRONIC DRIVERS:-

Drivers are convert the line voltage into a constant voltage or constant current on the output side, these drivers are available with different combinations of output voltage / Current total output power, housing and IP protection options.

Drivers are developed for the lighting industry and meet the requirements of relevant mandatory national and international standards for Electronic drivers.

Electronic Drivers are consuming a minimum of energy.

Electronic drivers are compact and require a minimum space for installation.

Electronic drivers are protected against short circuit and Electrical & Thermal overload.

The Drivers shall be having following Protections

Over Load,
Short circuit
Over temperature,
No load and partial load,
Surge protection,
Lightning Protection,

Internal Lighting:

- General Areas : Concealed/ surface mounted LED Lights.
- Corridors, Toilets, Change rooms, etc. : Concealed/ surface mounted LED lights.
- Service rooms like control room, etc. : Water proof light fittings with LED Lamps.
- Dimmers/ Occupational sensors. : Optional.

External Lighting:

- Street light poles : To suit width of roads. Extruded M.S. Poles with MH/T5/LED lamps.
- Landscape lights : To be selected.
- Flood lighting : To be selected.

Emergency Lighting System:

- Through Centralised Inverter or through Invertors in each floor.
- It shall have SMF Batteries to provide minimum 20 minutes back-up time.
- Emergency lighting shall cover all areas like lift, control room, conference room, etc.
- Minimum 10 to 15% of lighting system to be provided for corridors, investigation rooms, Waiting areas, Lobbies, Toilets, etc.
- Distribution system shall be separate for Emergency lighting system.

LIST OF APPROVED MAKES FOR ELECTRICAL WORKS

FOR ELECTRICAL WORKS

| Sl.No. | Items Description | Make of the Components |
|--------|--|--|
| 1 | XLPE Insulated L.T cables | POLYCAB / HAVELLS / FINOLEX / KEI / UNIVERSAL / GLOSTER |
| 2 | Flexible – Copper Cables / Control Cables / Special Cables | POLYCAB / HAVELLS / FINOLEX / LAPP / GLOSTER |
| 3 | Decorative Luminaries Fancy Light Fittings | Philips // BAJAJ/ WIPRO / HAVELLS / CG / HALONEX Philips // BAJAJ/ WIPRO / HAVELLS / CG / HALONEX |
| 4 | High efficiency fluorescent lamp | Osram / Philips / CG |
| 5 | Outdoor Light Fittings | Philips // BAJAJ/ WIPRO / HAVELLS / CG |
| 6 | LED Light Fittings | Philips // BAJAJ/ WIPRO / HAVELLS / CG / HALONEX |
| 7 | LED's | Cree / Luxion / Nichia/OSRAM |
| 8 | PIR Sensors – Digital only | Philips / /MK (Honeywel) |
| 9 | MCB/ RCDs/Surge suppressors /MCB Type Isolators | Hager/Schneider (MG) / ABB / LEGRAND |
| 10 | MCBs and MCBDBs (double shutter) | Hager/Schneider (MG) / ABB / LEGRAND |
| 11 | MPCBs | Schneider (NSX) / LEGRAND |
| 12 | Decorative type modular switches & Sockets | Great White/ Fiana/Anchor Lira / ANCHOR TRESA / LEGRAND / MK india |
| 13 | Heavy duty cable Lugs/ Cable glands | Dowells / SMI / Comet / Jainson |
| 14.1 | Industrial type Switch sockets – Moulded | SCAME /Legrand//Schneider/ |
| 14.2 | - Industrial Switch sockets - Industrial | SCAME /Legrand//Schneider |

| | | |
|------|--|--|
| 15.1 | MS Conduits | GB/Bharat / Supreme |
| 15.2 | FRLS Conduits | VIP/NATIONAL / SUDHAKAR / PRECISION |
| 16 | Wires (PVC/FRLS) | Anchor/ POLYCAB / FINOLEX / HAVELLS |
| 17 | Exhaust Fans | CROMPTON/GEC/Anchor/Almonard |
| 18 | Cable/Earth pit markers | Suraba/SMI |
| 19 | Terminals | Elmex / Wago |
| 20 | Rubber Mat | Jyothi |
| 21 | Push Button Station | Siemens / Teknic / Schneider |
| 22 | DOL/Star Delta Starter | Siemens/Schneider /Legrand |
| 23 | Earth pit marker | |
| 24 | Fire Barriers | 3M / Hilti / Viper |
| 25 | Cable Trays | Profab / Patny |
| 26 | Fabricated Wire ways / Raceways Readymade Wire ways / Raceways | Profab / Patny |
| 27 | Inverter With 1 and half Hour battery Backup | DUBAS/Consul neowatt/ Power one |
| 28 | Chemical Earthing/ Maintenance Free earthing | Jef Ecosafe /Galaxy |
| 29 | Transformers | Crompton Greaves/Kirloskar/Universal /GE/Schneider/ESSENER / VOLTAMP / PETE |
| 30 | HT Panels | Schneider / ABB/LEGRAND |
| 31 | PVC flexible conduit pipes | As per approval by consultants |
| 32 | 33 kV HT cables | POLYCAB / FINOLEX / HAVELLS / GLOSTER |
| 34 | Lightning system | Erico / Indelec |
| 35 | Street Light poles | Bajaj / K-Lites / Bombay Poles |
| 36 | Ceiling fans | Polar / Usha / Crompton / ORIENT |
| 37 | GI pipes | Jindal / Prakash / BEC |
| 38 | MS pipes | Tata / Sail / /Jindal |
| 39 | MS Steel | Tata / Sail |
| 40 | Cable jointing kit | Raychem |
| 41 | Transient Voltage Surge Suppressor | ASCO |
| 42 | Sandwich /air insulated Busducts/rising Mains | Godrej/Schneider/L&T/ C&S |
| 43 | Battery Charger | AMARON/ HBL-NIFE / DUBAS |
| 44 | SMF Battery | AMARON / Rocket /Panasonic/Exide |

LIST OF APPROVED MAKES FOR L.T SWITCHBOARDS AND COMPONENTS

| Sl.No. | Items Descriptions | Make of Components |
|--------|--|---|
| 1 | Switchboard manufacturer /Main power centre / Sub power control centre | Controls /Balaji Electro Controls / Indus electro controls / SV Karanth Techno systems |

| | | |
|----|---|---|
| 2 | ACB | Mitsubishi/ Schneider—NW series (MG) / ABB / L&T/LEGRAND Releases : Micrologic 6.0 A or equivalent |
| 3 | MCCBs / MPCBs | Mitsubishi/ Schneider –NSX series (MG) / ABB / L&T / LEGRAND |
| 4 | Contactors and O/L Relay | Schneider / Siemens |
| 5 | Load Monitors / Controller and all Digital meters | CIRCUTOR /INFO NRG |
| 6 | Multi Data Meters (MDM) with RS-485 port | CIRCUTOR /INFO NRG |
| 7 | MCBs | Hager/Schneider (MG) / ABB |
| 8 | Capacitor(Gas filled Type) | CIRCUTOR /EPCOS / SIEMENS /MEHER / GE / NEPUTUNE / L&T / SCHNIDER. |
| 9 | CTs and PTs | CIRCUTOR /Kappa /Kalpa |
| 10 | Control Switches | Kaycee / Siemens / Salzer |
| 11 | ELR / Earth Fault Relay | CIRCUTOR/CSPCL/ PROKDVS/ NUGUBA |
| 12 | Protective Relays | Schneider / CSPCL |
| 13 | Push Buttons | Siemens / Teknic / Schneider |
| 14 | Indicating lamps (LED type) | Siemens / Teknic / Schneider / VAISHNO /BINAY |
| 15 | Wires (HHFR)/FRLS/PVC | POLYCAB / FINOLEX / HAVELLS /Anchor |
| 16 | Lugs. Glands | Dowells / HMI / Comet / BRACO / HEX |
| 17 | Terminals | Elmex / Wago – Finger touch proof |
| 18 | Ferrules | Mayfair |
| 19 | Bus bar supports | Powermak or approved equivalent |
| 20 | Energy Meter with RS-485 Port | CIRCUTOR /INFO NRG |
| 21 | Panel Digital Meters | CIRCUTOR /INFO NRG / CONZERV / L&T / AE / SECURE |
| 22 | Name plates | Screen printed acrylic |
| 23 | Surge Protective Devices | ZOTUP/Schneider / OBO Bettermann |
| 24 | Power factor control relay | CIRCUTOR /EPCOS |
| 25 | Capacitor (MPP gas filled only), Inductor and Thyristor modules combination | CIRCUTOR /EPCOS |
| 26 | Switch fuse/Fuse switch / HRC fuses | EPCOS / Siemens |
| 27 | Power pack | Minilec / / Hi-rel |
| 28 | PLC load management | Allen Bradely / SIEMENS /HONEYWELL / JOHNSON |
| 29 | ATS | ASCO 7000 SERIES |

LIST OF APPROVED MAKES FOR 33kV HT PANELS & ACCESSORIES :

| | | |
|---|---|-------------------------------|
| 33kV Breakers | : | SCHNEIDER / ABB / L&T |
| 33kV On load isolator | : | SCHNEIDER / ABB / L&T |
| Indicating Meters | : | CIRCUTOR /INFO NRG |
| Trivector meter – Electronic Solid State With RS485 communication port. | : | L & T or Approved equivalent |
| Microprocessor based Numerical Relays | : | Siemens / Schneider / Areva |
| Microprocessor based Differential & other Relays | : | Siemens / Schneider / Areva |
| CTs & PTs | : | Kappa /Kalpa/ CIRCUTOR |
| Indicating Lamps & Push Buttons | : | Siemens / Schneider / Tecknic |
| Terminals | : | Phoenix / Wago / Elmex |
| ON-OFF Switch with lost motion device | : | Kaycee / Alstom |

LIST OF MAKES for 33kV outdoor items / equipments at point of supply shall be generally as per Local EB approved list

- | | | |
|---------------------------------|---|---|
| a) 33KV Gang Operated Air Break | : | Southern switchgear / Switchgear manufacturing company / AMEI power Ltd . |
| b) 33KV Lightning Arrestors | : | Oblum / LAMCO / Jayashree |
| c) 33KV Insulators | : | Jayashree / BHEL |

LIST OF MAKES FOR BUS DUCTS / RISING MAINS :

The busducts / rising mains of following makes shall be offered.

1. SuperBar, UAE
2. Godrej
3. Schneider
4. L&T
5. C&S

CODES

Codes shall mean the following including the latest ascendants and / or replacement if any.

- a) Indian Boiler Act, 1923 and Rules and Regulations made their under
- b) Indian Electricity Act, 1923 and Rules and Regulations made there under
- c) Indian Factories Act, 1948 and Rules and Regulations made there under
- d) The minimum wages Act
- e) The Women’s Compensation Act
- f) The Payment of Wages Act
- g) The Fatal Accident Act
- h) The Industrial Employment Act
- i) The Employment provident Fund Act
- j) Indian Explosive Act 1984 the Rules and Regulations made there under
- k) Indian Petroleum Act 1934, and Rules and Regulations made there under
- l) A.S.M.E. Test Codes
- m) AIRE Test, Codes

n) American Society of Materials Testing Codes

o) Standards of the Indian Standards Institution

- | | | |
|-----|---|---------------------------|
| 1) | Low Tension Circuit Breakers : | IS 2516-1955 Part I Sec.1 |
| 2) | Switchgear Bus Bars | IS 375-1963 |
| 3) | HRC fuse links | IS 2208-1962 |
| 4) | Distribution fuse boards | IS2675-1966 |
| 5) | Enclosure for Low Voltage switchgear | IS214701962 |
| 6) | PVC Cables | IS1554-1975 |
| 7) | Tabular fluorescent lamps for Cameral lighting service | IS2418-1963 |
| 8) | Tungsten Filament Lamps for cameral service | IS415-1963 |
| 9) | Ceiling Fans | IS274-1966 |
| 10) | Flood lights | IS1947-1961 |
| 11) | Wall Glass flame-proof electric light fittings | IS2206-1962 (Part 1) |
| 12) | Water Tight Electric Light Fittings | IS3553-1956 |
| 13) | Steel Boxes for Enclosure of Electrical Accessories | IS5133-1969 |
| 14) | Fittings for Rigid Steel conduit | IS2667-1979 |
| 15) | Rigid steel circuits for electrical wiring | IS3837-1966 |
| 16) | Accessories for Rigid Steel Conduits for Electrical Wiring | IS3837-1966 |
| 17) | Switch Socket Outlets | IS3837-1966 |
| 18) | PVC Wiring | IS694-1977 |
| 19) | Switches for domestic and similar purpose | IS3854-1966 |
| 20) | PVC wiring | IS694-1977 |
| 21) | Call Bell and Buzzers | IS2268-1966 |
| 22) | Straight through joint boxes and leads sleeves or paper insulated cables- | EID-0032-1964 |
| 23) | Earthing | IS3043-1966 |
| 24) | Electrical Wiring installations | IS732-1963 |
| 25) | Switchgear | IS3072-1965 (Part I) |
| 26) | Lighting protection | IS2309-1969 |
| 27) | Public Address system | IS1882-1962 |
| 28) | Low Tension switch use units | IS4064-1978 |
| 29) | Code of Practice for Automatic FIRE ALAM system | IS2189-1970 |
| 30) | Specification for Heat Sensitive Fire Detectors | IS2175-1977 |
| 31) | Guide for Safety procedure in Electric work | IS5216-1969 |
| 32) | Rubber Mats for Electric works | IS5424-1969 |

p) Other internationally approved standards and / or Rules and Regulations touching the subject matter of the contract

Specification of Lift

Electric Traction Elevator of various capacity to be installed for vertical transmission of officials / public. The elevators shall be of ThyssenKrupp, Johnson, OTIS, Mitsubishi & KONE make with mirror finishing having power operated automatic sliding door with ADR system conducive to be used in Offices.

Specification of Fire Protection, Detection and Public Address system

Complete fire and safety shall be designed and installed as per guidelines of NBC latest version.

The alarm system shall be addressable type.

Extra Low voltage system here after called ELV shall be designed and installed

Following ELV systems shall be installed.

- CCTV System
- Access Control & Attendance Management System
- Building Management System
- Conduit and wiring network is required for LAN/Data , Voice/Telephones, Television and landline call system

CODES & STANDARDS

Above mentioned ELV systems confirms following standards

- National Building Code (NBC) of India 2005, Part – 4, Fire and Life Safety.
- NFPA 72: 2013 - National Fire Alarm and Signaling Code (Only applicable NFPA Standards-As per relevant Indian Standards)
- Stipulations of local authority for Fire compliance, CCTV & others
- IEC 60849: 1998 - Sound systems for emergency purposes
- ASHRAE \ ANSI 135 : 2004 - BACnet - A Data Communication Protocol for Building Automation and Control Networks

CCTV System

Analog CCTV system with Cat 6 cable network shall be installed to surveillance / monitors the critical and important areas in the premises. CCTV system allows the facility management and operations personnel to manage the facilities from single (or) multiple locations through digital video recorder with TCP/IP compatibility.

System Design and description

Analog cameras shall be connected to 8 / 16 channel digital video recorder using Cat 6 cable and same shall be connected to 32" LED display sy. Continuous storage of 30 days to be considered

Capacity & number of Cameras: Cameras shall be installed @ all strategic like waiting areas, Pharmacy, Main lobby, Entry & exit point of premises,

ACCESS CONTROL SYSTEM & ATTENDANCE MANAGEMENT SYSTEM

Independent (not centralized) access Control system with reader cum controller shall be installed to restrict the unauthorized entries to only to the specific areas of the buildings and also an attendance Management System is proposed to record the presence of the employees from one point.

Access Control system is proposed to restrict the unauthorized entries into the following areas / locations;

System Description

Access controller cum reader for entry side of office and and pushbutton on exit side of doors shall be fixed. Biometric reader is proposed in entrance of the building for attendance purpose.

BUILDING MANAGEMENT SYSTEM

Building Management system including conduiting, cabling/wiring hardware, protocol software is proposed to control and monitoring the HVAC systems, for monitoring electrical system, PHE, and interfacing with fire panel , fire alarm & detection system.

Building Management System shall be with BACnet platform and third party integration at the supervisory level on BACnet, LON works, Modbus, Mbus etc.,

Building Management System shall consist of the following

- Workstation with 32" LED Monitor
- Software
- Third Party Integrator / Gateway
- Direct Digital Controller
- Field Devices like Temperature Sensor, RH Sensor, Differential Pressure Switch, Level Transmitter etc.,
- Signal and communication cable

System Description

BMS shall control and monitor the following HVAC equipments;

Air cooled Chillers
Primary Pumps
Floor Mounted Air Handling Units
Vertical Mounted Air Handling Units
Ceiling Suspended Air Handling Units
CHW & DX Units
Ventilation Fans
Exhaust Air Fans
Pressurization Fans

BMS shall monitor the following PHE equipments;

Raw Water Pump
Soft Water Pump
Submersible Pump
Water Sump & Tanks
Line Pressure
Make-up Water Pumps

BMS shall monitor the following FPS equipments;

Main Pump
Sprinkler Pump
Jockey Pump
Diesel pump
Water Tanks
Line Pressure
BMS shall monitor the following third party systems;
Variable Frequency Drive (VFD)
Fire Alarm Control Panel (FACP)
Uninterrupted Power Supply (Central UPS)
Energy Meters (EM)

CODES & STANDARDS

The equipment and installation work shall conform to latest editions of applicable Indian / International Standards. The standards shall include but not be limited to the following: National Building Code (NBC) of India latest version, Part – 4, Fire and Life Safety.

- Stipulations of local authority.
- IEC 60849: 1998 - Sound systems for emergency purposes.

All the security systems shall be installed complying with the following codes and regulations.

- National and local statutory regulations.
- Health & safety at Work Acts.
- IEE Regulations
- Equipment manufacturer's instructions.
- Regulations and conditions of utilities suppliers.
- Any statutory Safety Guides.

LIST OF MAKES

Fire Detection and Alarm System

- | | |
|--|---|
| 1) Fire Alarm & Control Panel | - Bosch / Cooper / Edwards / Schrack |
| 2) Repeater Panel (Optional) | - Bosch / Cooper / Edwards / Schrack |
| 3) Detectors / Manual Call Point /Hooter / Modules | - Bosch / Cooper / Edwards / Schrack |
| 4) Response Indicator | - Agni / Madhushree / Firepro / Protech |
| 5) Batteries | - Amaron / AMCO / Panasonic |

Public Address System

- | | |
|---------------------------------------|--------------------------------|
| 1) Controller | - Bosch / Heinrich / Honeywell |
| 2) Router | - Bosch / Heinrich / Honeywell |
| 3) Call Station / Call Station Keypad | - Bosch / Heinrich / Honeywell |
| 4) Amplifier / Speaker | - Bosch / Heinrich / Honeywell |

Two way Talk Back System

- | | |
|---|---|
| 1)Main Console with Microphone /Amplifier / Talk Back Speaker | - Haritasa / Heinrich / e-Building Technologies |
|---|---|

CCTV System

- | | |
|----------------------------------|--|
| 1) Camera / Mounting Accessories | - Bosch / Honeywell / L&T / Panasonic / Schneider – Pelco / Sony |
| 2) Digital Video Recorder | - Bosch / Honeywell / L&T / Panasonic /Schneider – Pelco / Sony |
| 3) Display | - LG / Panasonic / Samsung / Sony |

Access Control System

- | | |
|--------------------------|---------------------------|
| 1) Reader cum Controller | - HID |
| 2) Card | - HID |
| 3) Electromagnetic Lock | - Algatec / BEL / Capture |

Cables

- | | |
|---|---|
| 1) Signal Cable / Power Cable / Control Cable / Communication Cable | - Caliplast / Deepanjan Power / Polycab /Varsha /V-cables |
| 2) CAT6 UTP Cable | - Tyco / R&M / Siemon |

Building Management system

- | | |
|--------|----------------------|
| 1) BMS | - Seimens/ HoneyWell |
|--------|----------------------|

HVAC WORKS

STANDARDS AND GUIDELINES

The System design & installation will be done with reference to the following:

- ❖ Relevant Bureau of Indian Standard Codes (BIS)
- ❖ ASHRAE standards.
- ❖ Duct Construction Standards as per relevant BIS Codes and SMACNA.
- ❖ NBC latest version
- ❖ Energy Conservation Building Code (ECBC) latest version
- ❖ NABH of India 4th edition
- ❖ AERB compliance

Design parameters

Ambient design conditions: as per local conditions

Indoor environmental requirements: The air-conditioning system and services broadly categorised as under to maintain temperature, humidity, pressure, air changes and air quality.

Admin & Back Offices, dining:

Ventilation Zones: Toilets / Dirty Utility (DU) ,Kitchen, Staff & Locker Room, Electrical Room, STP & WTP, Plant room.

**SECTION 6:
SECURITIES AND OTHER FORMS**

BID SECURITY (BANK GUARANTEE)

WHEREAS, _____ [name of Bidder] (hereinafter called "the Bidder") has submitted his Bid dated _____ [date] for the construction of [name of Contract hereinafter called "the Bid"].

KNOW ALL PEOPLE by these presents that We _____ [Name of Bank] of _____ [name of country] having our registered office at _____ (hereinafter called "the Bank") are bound unto [name of Employer] (hereinafter called "the Employer") in the sum of _____ * for which payment well and truly to be made to the said Employer the Bank itself, his successors and assigns by these presents.

SEALED with the Common Seal of the said Bank this _____ day of _____ 20.

THE CONDITIONS of this obligation are:

- (1) If after Bid opening the Bidder withdraws his bid during the period of Bid validity specified in the Form of Bid;
- OR
- (2) If the Bidder having been notified to the acceptance of his bid by the Employer during the period of Bid validity:
 - (a) fails or refuses to execute the Form of Agreement in accordance with the Instructions to Bidders, if required; or
 - (b) fails or refuses to furnish the Performance Security, in accordance with the Instructions to Bidders; or
 - (c) does not accept the correction of the Bid Price pursuant to Clause 27

We undertake to pay to the Employer up to the above amount upon receipt of his first written demand, without the Employer having to substantiate his demand, provided that in his demand the Employer will note that the amount claimed by him is due to him owing to the occurrence of one or any of the three conditions, specifying the occurred condition or conditions.

This Guarantee will remain in force up to and including the date 45 days after the deadline for submission of Bids as such dead-line is stated in the Instructions to Bidders or as it may be extended by the Employer, notice of which extension(s) to the Bank is hereby waived. Any demand in respect of this guarantee should reach the Bank not later than the above date.

DATE _____

SIGNATURE _____

WITNESS _____

SEAL _____

[Signature, name and address]

* The Bidder should insert the amount of the guarantee in words and figures denominated in Indian Rupees. This figure should be the same as shown in Clause 16.1 of the Instructions to Bidders.

** 45 days after the end of the validity period of the Bid. Date should be inserted by the Employer before the Bidding documents are issued.

PERFORMANCE BANK GUARANTEE

To

_____ [name of Employer]
_____ [address of Employer]

WHEREAS _____ [name and address of Contractor] (hereafter called "the Contractor") has undertaken, in pursuance of Contract No. _____ dated _____ to execute _____ [name of Contract and brief description of Works] (hereinafter called "the Contract").

AND WHEREAS it has been stipulated by you in the said Contract that the Contractor shall furnish you with a Bank Guarantee by a recognized bank for the sum specified therein as security for compliance with his obligation in accordance with the Contract;

AND WHEREAS we have agreed to give the Contractor such a Bank Guarantee:

NOW THEREFORE we hereby affirm that we are the Guarantor and responsible to you on behalf of the Contractor, up to a total of _____ [amount of guarantee]* _____ (in words), such sum being payable in the types and proportions of currencies in which the Contract Price is payable, and we undertake to pay you, upon your first written demand and without cavil or argument, any sum or sums within the limits of _____ [amount of guarantee] as aforesaid without your needing to prove or to show grounds or reasons for your demand for the sum specified therein.

We hereby waive the necessity of your demanding the said debt from the contractor before presenting us with the demand.

We further agree that no change or addition to or other modification of the terms of the Contract or of the Works to be performed there under or of any of the Contract documents which may be made between your and the Contractor shall in any way release us from any liability under this guarantee, and we hereby waive notice of any such change, addition or modification.

This guarantee shall be valid until 28 days from the date of expiry of the Defect Liability Period.

Signature and Seal of the guarantor _____

Name of Bank _____

Address _____

Date _____

* An amount shall be inserted by the Guarantor, representing the percentage the Contract Price specified in the Contract including additional security for unbalanced Bids, if any and denominated in Indian Rupees.

BANK GUARANTEE FOR ADVANCE PAYMENT

To

_____ [name of Employer]
_____ [address of Employer]
_____ [name of Contractor]

Gentlemen :

In accordance with the provisions of the Conditions of Contract, sub-clause 47.1 ("Advance Payment") of the above-mentioned Contract, _____ [name and address of Contractor] (hereinafter called "the Contractor") shall deposit with _____ [name of Employer] a bank guarantee to guarantee his proper _____ and faithful performance under the said Clause of the Contract in an amount of _____ [amount of Guarantee] * _____ [in words].

We, the _____ [bank or financial institution], as instructed by the Contractor, agree unconditionally and irrevocably to guarantee as primary obligator and not as Surety merely, the payment to _____ [name of Employer] on his first demand without whatsoever right of obligation on our part and without his first claim to the Contractor, in the amount not exceeding _____ [amount of guarantee]* _____ [in words].

We further agree that no change or addition to or other modification of the terms of the Contractor or Works to be performed thereunder or of any of the Contract documents which may be made between _____ [name of Employer] and the Contractor, shall in any way release us from any liability under this guarantee, and we hereby waive notice of any such change, addition or modification.

This guarantee shall remain valid and in full effect from the date of the advance payment under the Contract until _____ [name of Employer] receives full repayment of the same amount from the Contractor.

Yours truly,

Signature and Seal : _____
Name of Bank / Financial Institution : _____
Address: _____
Date: _____

* An amount shall be inserted by the Bank or Financial Institution representing the amount of the Advance Payment, and denominated in Indian Rupees.

UNDERTAKING

I the undersigned do here by undertake that our firm M/s..... Agree to abide by this bid for a perioddays for the date fixed for receiving the same and it shall be binding on us and may be accepted at any time before the expiration of that period.

(Signed by an authorized officer of the Firm)

Title of Officer _____ Name of
the firm _____ DATE

SECTION 7

DRAWINGS

**INDICATIVE SITE PLAN WITH TECHNICAL DETAILS
/SPECIFICATIONS TO BE ATTACHED / PROJECT DETAILS &
SCOPE OF WORK (TO BE ATTACHED)**

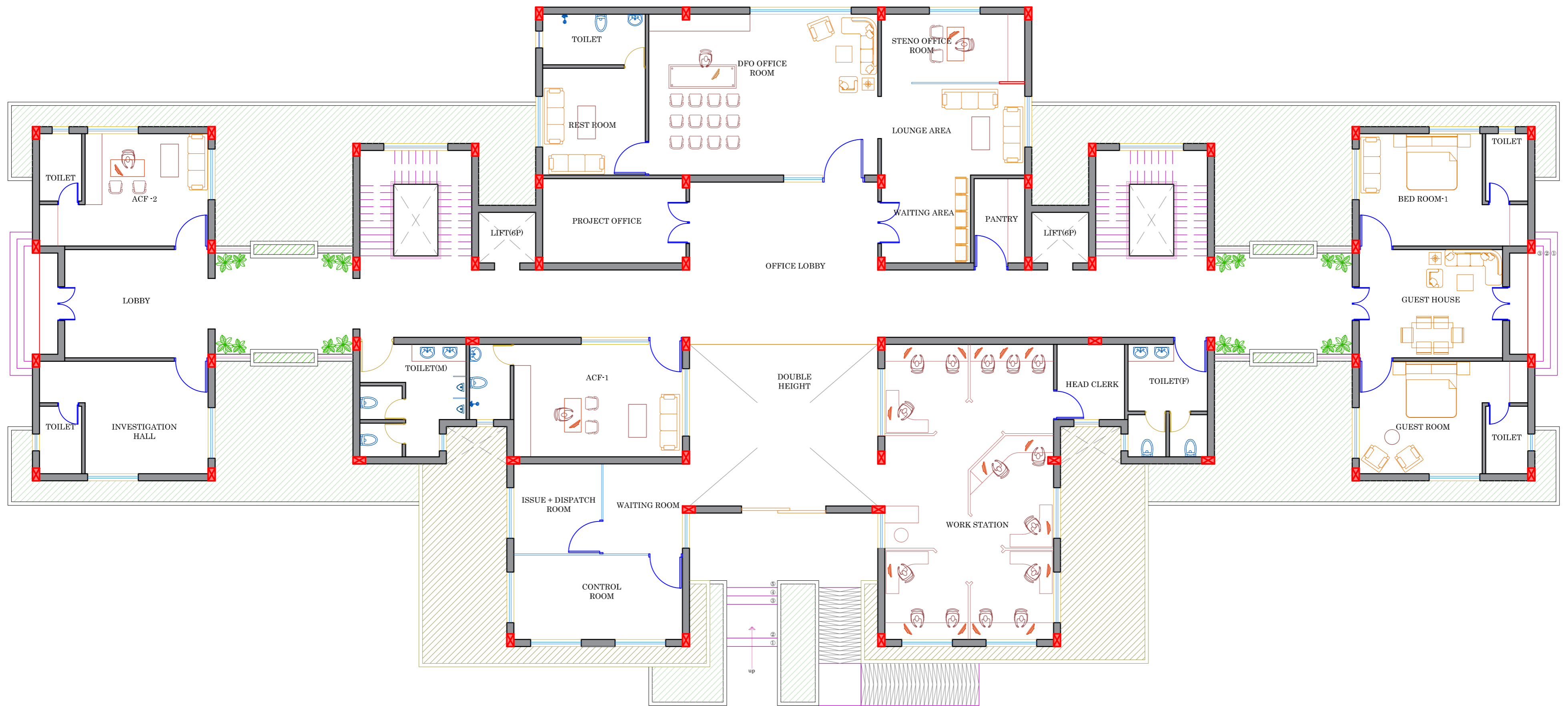
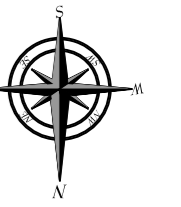

PROPOSED OFFICE BUILDING @ DFO PURI
GROUND FLOOR PLAN LAYOUT

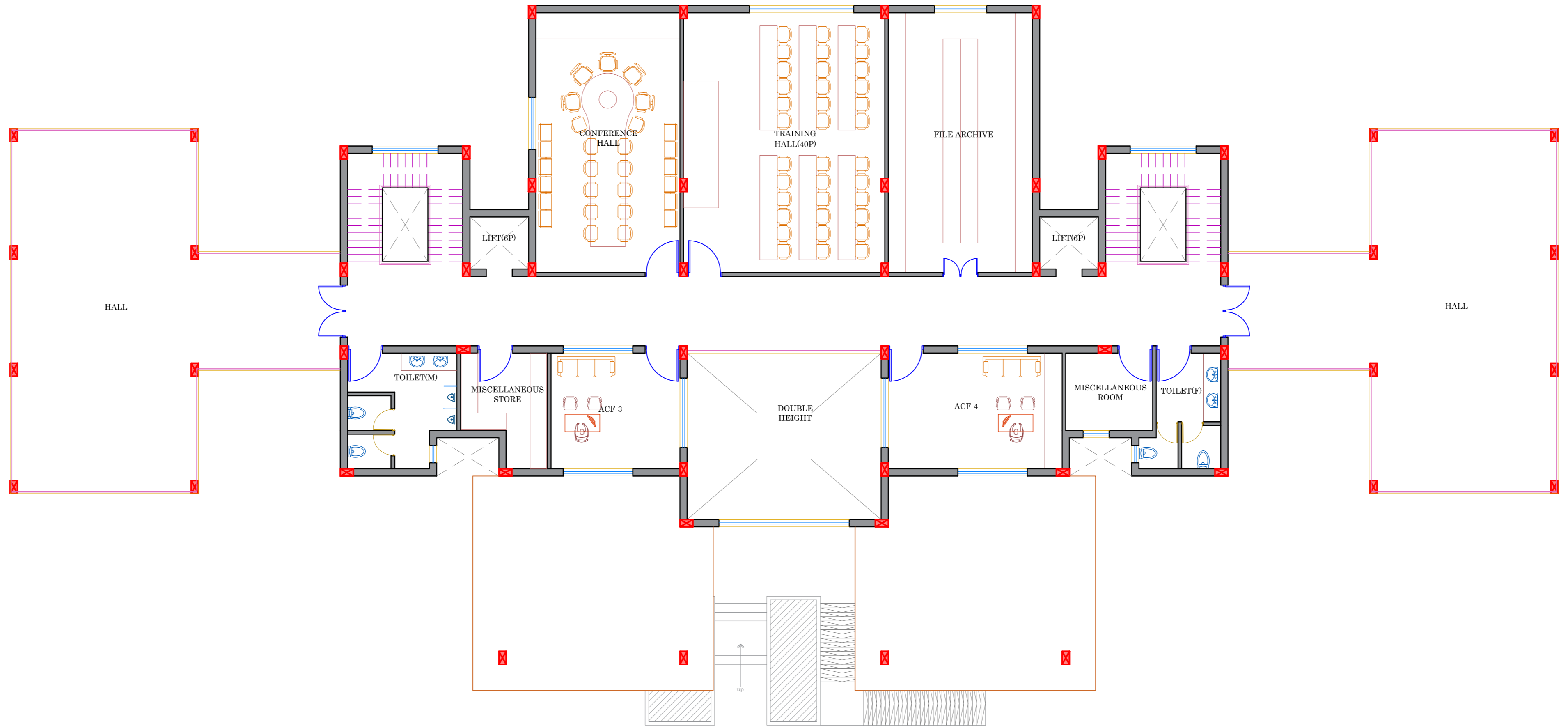
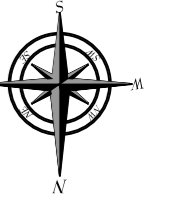

PROPOSED OFFICE BUILDING @ DFO PURI
FIRST FLOOR PLAN LAYOUT

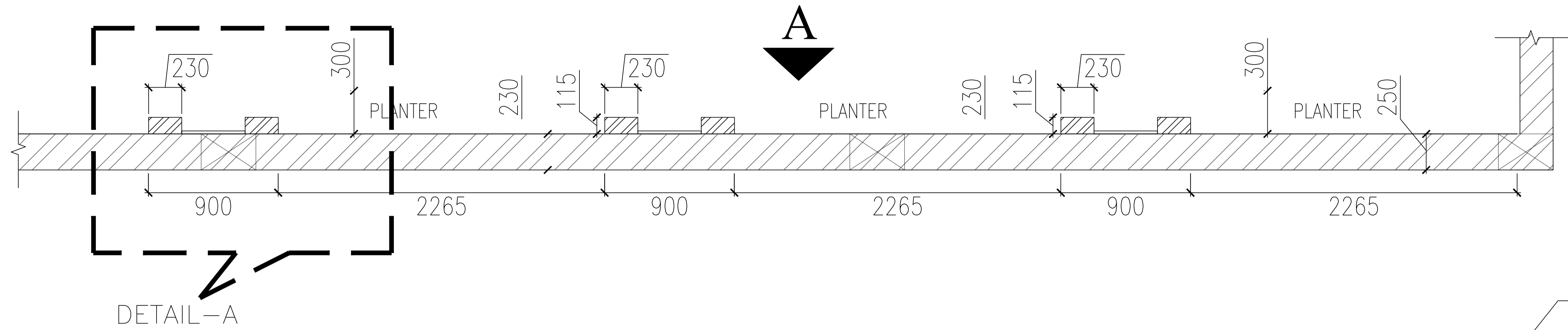

DETAIL-A

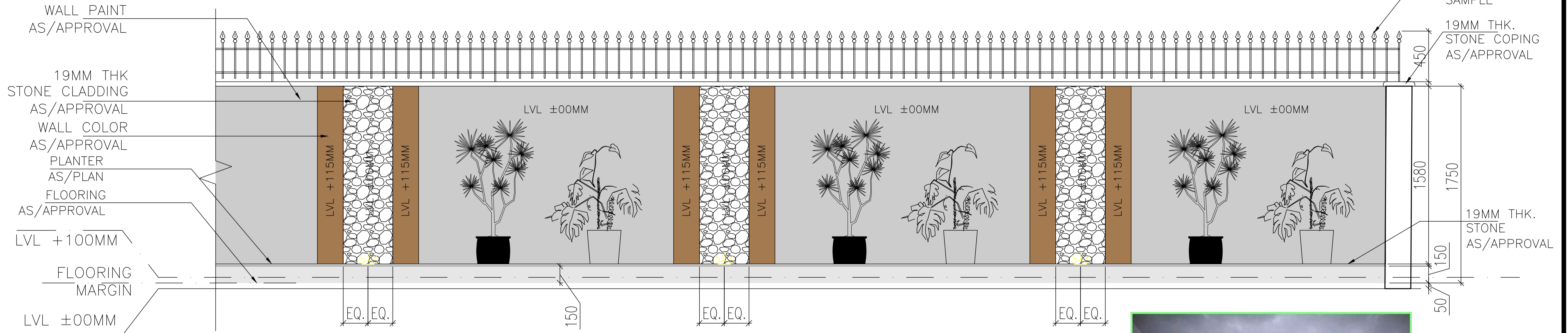

ELEVATION-A

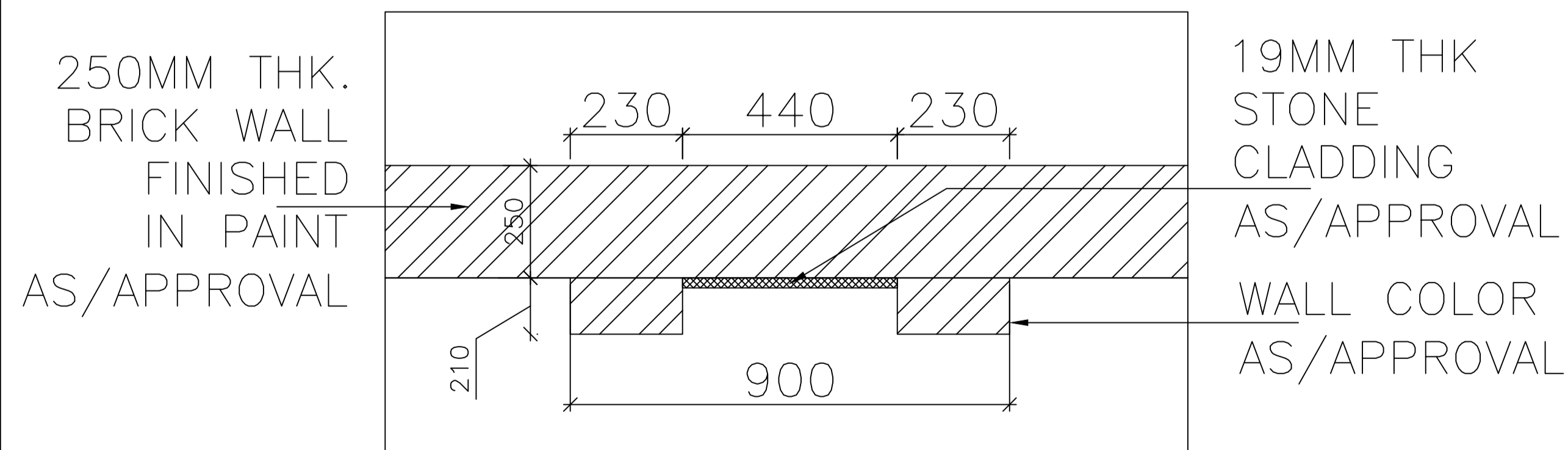

DETAIL-A

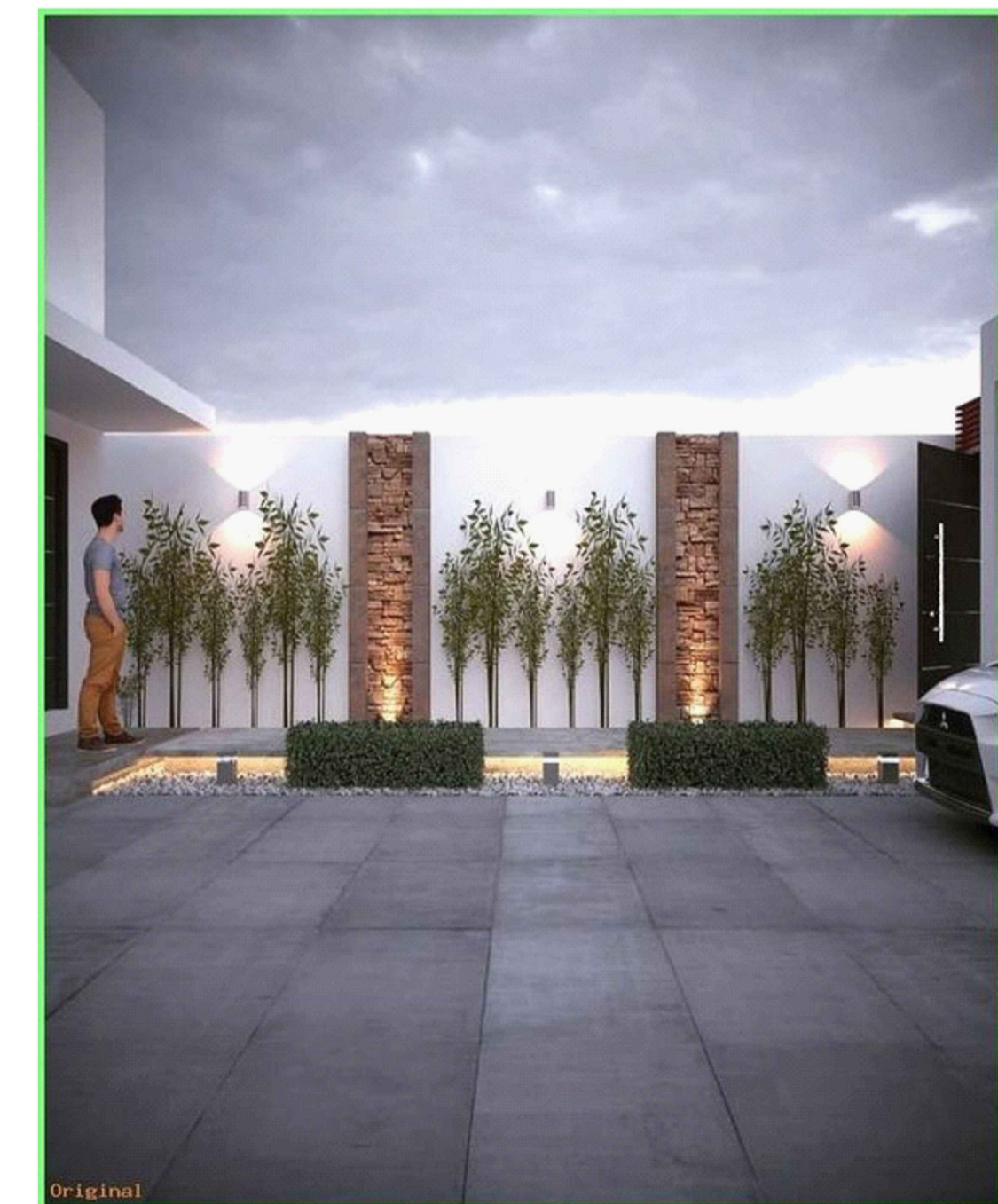

REFERENCE IMAGE

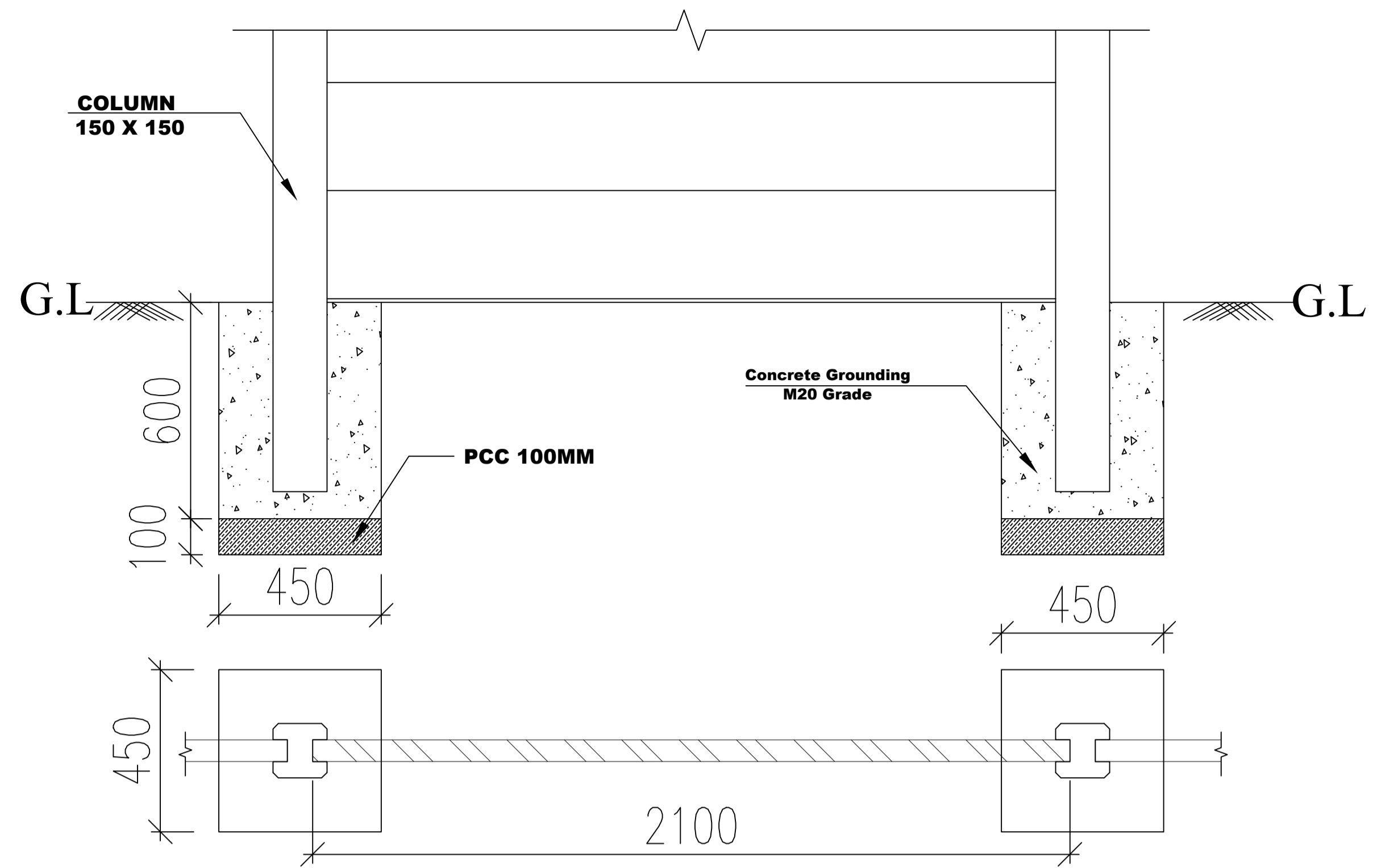

PRECAST WALL INSTALLATION

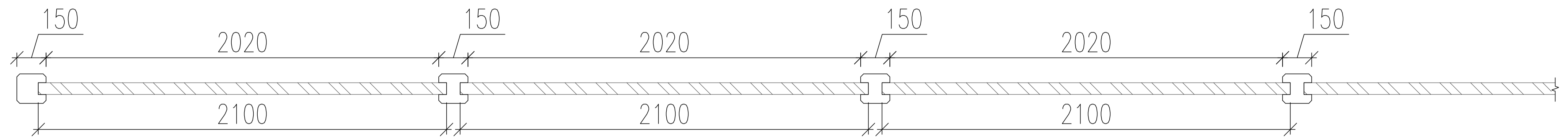

PLAN OF PRECAST BOUNDARY WALL

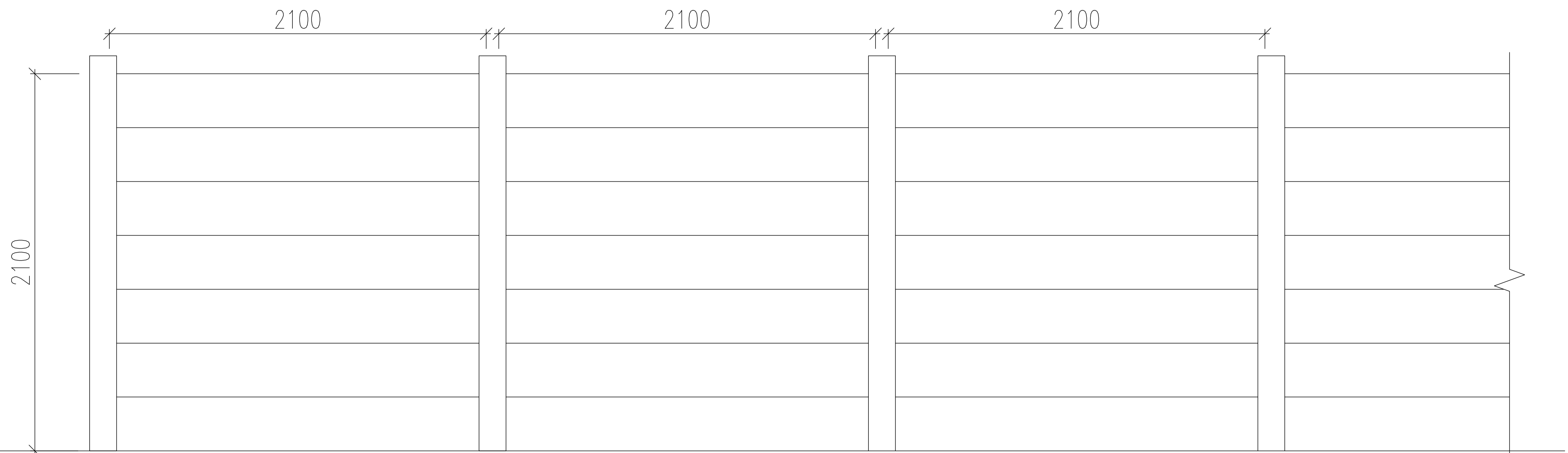

ELEVATION

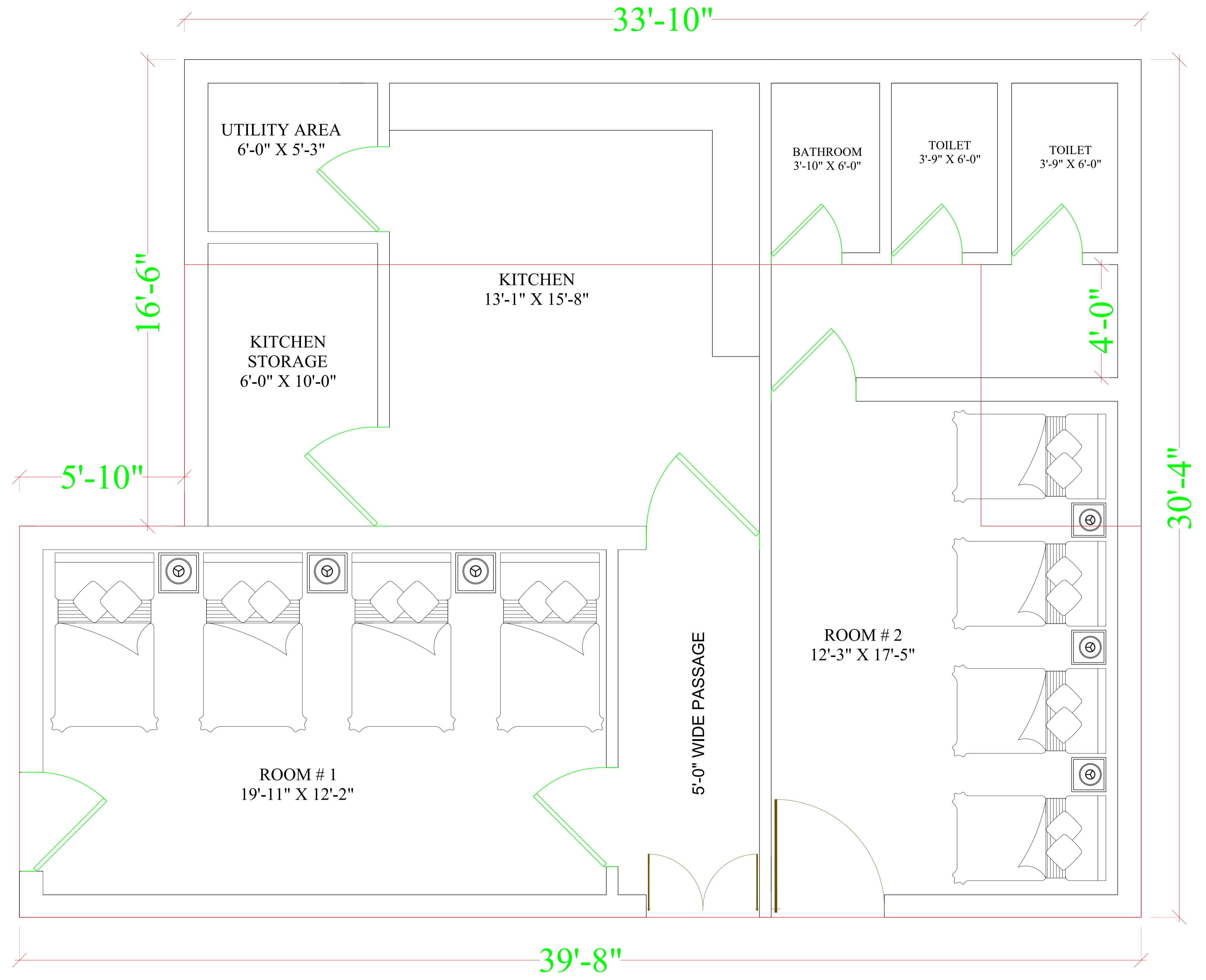

| CONSTRUCTION OF DIVISIONAL FOREST OFFICE WITH BOUNDARY WALL IN PURI WILDLIFE DIVISION | | | |
|---|---|--------------|--|
| SL NO. | DESCRIPTION | AREA IN SQFT | SPECIFICATIONS |
| A | OFFICE BLOCK INCLUDING STAFF BUILDING | 14400 | |
| 1 | GROUND FLOOR | | <ol style="list-style-type: none"> Parking area: - Industrial Vetrified Tiles 300mmx300mm size. Structure: - RCC Framed structure and clear roof height of minimum 13 feet. Office Block area includes area of staircases and construction for Lift area and of Staff room. Flooring:- All areas finished with fully charged vitrified tiles of minimum 10 mm thick & size of 600x 600 mm (Preferably Johnson, KAJARIA, Somany, Orient-Bell make) fully charged Vitrified Tiles (GVT) of matt finish (WOODEN FINISH / RUSTIC FINISH/other approved finish) with Anti-ageing / High abrasion resistance glaze composition (Scratch free/Stain free) with water absorption limit between 0.08% to 3% and conforming to IS:15622:2006(Group B lb)in floor. CLEAR ROOF HEIGHT – min 13'-0" including double height as shown in the drawings wherever applicable, with slanting roofs, pile foundation up to 6 feet Wall Finishing: - Internal walls finished with Cement Based Putty finish and Acrylic emulsion paint. Alternate, wall finish of superior quality will be provided. External walls finished with Exterior Grade Acrylic emulsion paint and Texture paint. Germ free floor tiles / Anti-bacterial wall tiling of size 600mm x 300mm in all Ots. Conference rooms, investigation rooms and training rooms are of Acoustic wallpaneling. False ceiling: - Mineral Fiber board (Armstrong) false ceiling and Gypsum board false ceiling for all places in air condition areas with white cement paint on Gypsum board ceiling and other areas. Record rooms will be equipped with standard storage facilities along with fire detection system. Electrical: <ol style="list-style-type: none"> Fans & lights as per requirement including A.C. areas. All critical areas such as shall have DG back up for AC and for rest areas shall have DG back up for light and fan.Lift shall have DG back up. Networking facilities & Voice cabling for Training rooms, investigating rooms, conference, DFO and ACF offices, control rooms and section offices. CCTV coverage will be provided to the office building as well as office outdoor |
| 1.a. | RECEPTION AREA | 350 | |
| 1.b. | WAITING AREA | 340 | |
| 1.c. | CONTROL ROOM | 180 | |
| 1.d. | ISSUE AND DISPATCH ROOM | 100 | |
| 1.e. | WORK STATION | 500 | |
| 1.f. | HEAD CLERK | 50 | |
| 1.i. | DFO OFFICE ROOM+A.TOILET | 500 | |
| 1.j. | DFO REST ROOM AND REST ROOM INCLUDING PROJECT OFFICE | 300 | |
| 1.k. | STENO ROOM | 110 | |
| 1.l. | PANTRY | 50 | |
| 1.m. | ACF (2NOS)+A.TOILET | 220 | |
| 1.o. | INVESTIGATION+A.TOILET | 220 | |
| 1.p. | GUEST HOUSE (2-BHK) | 650 | |
| 1.q. | COMMOM TOILET(M) | 120 | |
| 1.r. | COMMOM TOILET(L) | 120 | |
| 2 | FIRST FLOOR | | |
| 2.a. | CONFERENCE HALL | 450 | |
| 2.b. | FILE ARCHIVE | 450 | |
| 2.c. | TRAINING HALL | 650 | |
| 2.d. | STORE ROOM | 150 | |
| 2.e. | ACF (2NOS) + A. TOILET | 250 | |
| 2.f. | COMMOM TOILET(M) | 120 | |
| 2.i. | COMMOM TOILET(L) | 120 | |
| 3 | Staff Building | | |
| 3.1 | One number of furnished Kitchen and 2 number of furnished Beds as per drawing | 1200 | |
| 4 | PARKING | 5000 | |
| 4.a | 15-4 WHEELER PARKING | | |
| 4.b | 20-2WHEELER PARKING | | |
| B | BOUNDARY WALL | 700 METER | |
| C | Landscaping | 0.8 acre | |
| D | Water Harvesting Facility | | |

| | | | |
|--|--|--|---|
| | | | <p>premises with connectivity and storage to the control room.</p> <p>5. Conduit provisions including the installation of LED projectors and AV system connectivity for conference hall and training room.</p> <p>6. Air Conditioning Air conditioning shall be provided at all places except Corridors, and Toilets.</p> <p>7. Investigation rooms will be fitted with audio and video recording devices. Safe Locker facilities will be provided in the DFO and ACF offices for firearms and in record room and investigation room for evidence keeping.</p> <p>8. Conference rooms, training rooms, control rooms and investigation rooms will be equipped with AV screens, computers, printers etc.</p> <p>10. P.H.:</p> <p>1) All Fittings as per requirement.</p> <p>2) Toilet doors should be of F.R.P. I.S. Standard.</p> <p>11. Fire Protection System: as per NBC 2016 norms/ latest NBC and Fire Safety Acts.</p> <p>12. Water harvesting structure at a distance of 800 meter from the main building to catch the water from the DFO Office Building.</p> <p>13. Furnishing of the office buildings includes furnishing of all rooms with sufficient numbers of furniture (including classroom furniture), sofas (20 no), office chairs (100 numbers) curtains, blinds, art works but does not involve electrical equipment addressed in SN 9 above in all offices as shown in drawings of specified brands (Godrej/Featherlite).</p> <p>14. Boundary wall – 350 meters as per drawing A and 350 meters precast boundary wall.</p> <p>15. Landscaping work will involve grass turfing, stouts, plantation etc. and cover minimum of 0.8 acre of the area.</p> |
|--|--|--|---|

SECTION-8

TERMS OF REFERENCE & SCOPE OF WORK FOR DESIGN OF THE PROJECT

1. BRIEF TASKS TO BE CARRIED OUT AT DESIGN & EXECUTION STAGE

- Collect sub-soil data, undertake detailed survey & sub-soil investigations;
- Prepare Detailed designs and architectural drawings,
- Whenever required or necessitated by the site conditions, modify designs as well as suggest solutions to the problems come across during actual execution.
- Obtain approval of designs of each component of buildings from the Director Designs, Odisha before execution.

2. DETAIL SCOPE OF WORK

- a) Conduct necessary sub-soil investigation, wind data and earthquake data as per relevant clauses of NBC of India.
- b) Carry out field surveys, soil and geo-technical investigations, and prepare plans, designs, detailed drawings, etc. as per the latest BIS and NBC guidelines.
- c) Prepare detail site plan of the area using total-station etc.
- d) Prepare Key map (with scale 1:50,000) showing the location of the buildings investigated and rejected and the important structures, in the vicinity. The reference to the position of the benchmark, location of the trial pits or bore-holes giving identification number for each bore connected to the datum and location of all nullahs, buildings.
- e) Carryout Geotechnical Investigations and Sub-Soil Exploration at each proposed building location, and conduct all relevant laboratory and field tests on soil and rock samples. Soil bore particulars duly indicating the classification of soils within a bore log chart and soil test reports conducted in Govt. of Odisha approved soil testing laboratory on undisturbed and disturbed samples for all the geo-technical parameters like C , ϕ , Atterberg limits, DFS, SPT and silt factor worked out from the mean diameter of the particle size to the maximum scour level, safe bearing capacity of soils or rocks, core recovery (RQD) for rock, errodibility test for rocks, consolidation settlement parameters etc.
- f) Prepare detailed designs, prepare drawings for building and approaches following the latest IS codes for design and construction of buildings and NBC specification and IS codes and obtain approval of the Director Designs, Odisha.
- g) Carryout load testing on piles as per BIS guidelines and accordingly modify the designs of foundation (pile and pile cap etc.) if necessary, from stability point of view.
- h) Brief details of the various elements of the proposed Project are presented in the following section (to be attached).
- i) The activities required for completion of the Project on a turnkey basis include

- Planning of the Facilities including functional analysis, workflow analysis etc.
 - Design development including preparation of architectural brief, design concept, concept for services etc. It may be noted that the concept plans forming part of the RFP documents shall be the basis for this.
 - Detailed design Engineering including architectural design and construction documents, structural Engineering, electrical Engineering, heating ventilation and air conditioning plans, communication and networking plan, fire detection and protection plan etc.
 - Building construction and installation of all services
 - Procurement, installation, testing and commissioning of requisite equipment as per specifications provided
 - Procurement and installation of furniture and fixtures
 - Project Management to ensure completion of Project as per the specified timelines
 - Compliance with Environmental and Energy efficiency norms and obtaining at least 4-star GRIHA rating.
 - Handing over of the facilities after fulfilling all the obligations under “Employer’s Requirement”
- ii) The details of the various components of the Project are as follows:
(to be inserted as per requirement)

3. TIME PERIOD FOR THE SERVICE

The time period for the design stage is 60 days from the date of commencement. This period includes time period for all types of survey & investigation as listed at Para-2, soil exploration and laboratory testing, detail design, the draft and final design reports, drawings, technical specifications, methodology of work and all other associated reports and documents.

However, the total period of contract including Survey, Investigation, Design, and Execution will be 12 calendar months. The defect liability period shall be three years from the date of completion of the project.

The Contractor shall submit all designs, drawings, technical specifications and methodology to the Employer **after vetting the same from any Institute of Repute at its own cost.** The Employer shall give approval on all sketches, drawings, reports and recommendations and other matters and proposals submitted for approval by the Bidder in such reasonable time as not to delay or disrupt the performance of the Contractor’s services.

4. SCHEDULE FOR COMPLETION OF TASKS

The reports have to be submitted in the following phasing in the number of copies indicated against each of them.

| SI No | Description | Schedule for completion |
|-------|---|--|
| 4.1 | Inception report* | 10 days from the date of commencement |
| 4.2 | Details of all Survey including laboratory test report | 15 days from the date of commencement |
| 4.3 | Draft Architectural Drawings with detail Engineering Designs and technical specifications & methodology | 20 days from the date of commencement |
| 4.4 | Final Architectural Drawings with detail Engineering Designs and technical specifications & methodology | 30 days from the date of commencement |
| 4.5 | Changes during Construction | As and when referred by the Department |

Note: * Inception report will broadly contain Site Appreciation, Identification of Secondary Data Requirement, Detailed, Breakdown of Investigations and Surveys to be carried out and a work program.

5. KEY PERSONNEL OF THE PROJECT DESIGN TEAM

The Bidder shall be required to form a multi-disciplinary team for this assignment with qualified & experienced key personal and other required supporting staff for delivering the final output of this section as per Para 7 below. The design as well as Architectural team should have the requisite experience and expertise for design of similar works as offered by the bidder and accepted by the Employer.

The CVs of the following Key Personnel would have to be got approved by the Divisional Forest Officer, during contract negotiation and prior to signing of contract.

A) Team leader & Building Design Engineer:

A Post Graduate Degree in Structural Engineering (Civil) with 8 years or a Degree in Civil Engineering with 15 years of minimum experience in Design of Building works and detailing of major RCC/ PSC/ STEEL-CONCRETE COMPOSITE SUPERSTRUCTURE with different types of foundations including PILE FOUNDATIONS for buildings.

B) Geotechnical Engineer and Building Foundation Expert

A Post Graduate Degree in Civil Engineering in Geo-technical or Foundation Engineering having a minimum of 8 years or Degree in Civil Engineering having a minimum of 10 years' experience out of which at least 5 years of experience in supervising soil and geo-technical investigations for major building works, design of foundations of all types including large diameter piles for building structures and construction of major buildings.

C) Architect

A Graduate Degree in Architect having a minimum of 10 years' experience out of which at least 5 years of experience for preparation of Office Building planning detailing for major buildings.

D) Electrical Engineer

A Graduate Degree in Electrical Engineering having a minimum of 10 years of experience.

E) Mechanical Engineer

A Graduate Degree in Mechanical Engineering having a minimum of 10 years of experience.

6. SERVICES TO BE PROVIDED BY THE DEPARTMENT

The department will provide the following available data to the Bidder on request.

- Available details of sub-soil report and other associated data
- Available details of soil bore log and test result
- Available site plan
- Any other relevant secondary data, to the extent available in comprehensive manner

7. FINAL OUTPUTS (REPORTS, DRAWINGS etc.) required from the Bidder

- | | | |
|-----|---|----------|
| 7.1 | Inception report | 5 copies |
| 7.2 | Report with details of all Survey including laboratory test | 5 copies |
| 7.3 | Draft detailed Architectural drawing and Engineering designs report | 5 copies |
| 7.4 | Final detailed Architectural drawing and Engineering designs report | 5 copies |

7.5 Except inception report, all other reports as listed above shall be submitted by the Contractor to the Employer only after obtaining approval of the same from any National Institute of Repute such as Indian Institute of Technology (IIT) at Contractor’s own cost. Such approved documents need to be furnished to the Employer within the stipulated datelines as mentioned at Section-4 in the contract data.

8. PAYMENT SCHEDULE AT ARCHITECTURAL DRAWINGS AND DESIGN STAGE

The architectural drawings and design cost for the building shall be 4% of the Contract Price. The client shall effect payments for the design cost in accordance with the following payment schedule.

| SI. | Activity / Deliverable | Payment as % of Design Cost |
|-----|---|-----------------------------|
| 1. | On approval of inception report & details survey and architectural drawing approved by concerned development authorities. | 20 |
| 2. | On approval of structural design. | 30 |
| 3 | On approval of Final Architectural drawing showing electrical and sanitary diagram and detail structural design. | 20 |
| 4 | On Completion of Construction | 30 |

SECTION 9

PROJECT EXECUTION & SUPERVISION ASPECTS, CONTRACT MANAGEMENT FRAMEWORK & PAYMENT SCHEDULE

A. PROJECT EXECUTION & SUPERVISION ASPECTS

A-1. The Bidder, who shall act as contractor for the project shall be composed of qualified and experienced experts, who can carry out all the routine construction works as a fully competent and independent unit.

However, in preparing his proposal for the construction, the Bidder should allow for a suitable mechanism which will ensure thorough co-ordination of the design and execution teams, so that each team is at all times fully aware of the remedies to common problems used by the other team.

A-2. **Lead Project Engineer** on behalf of the bidder (Contractor) should be named in the contract with whom day to day interactions shall be made by the Divisional Forest Officer for execution and supervision of works. He should be a senior Civil Engineer with at least 20 years of professional experience out of which 10 years in design and construction of building works. He should have executed at least one major building work of similar in nature as proposed by the bidder. He should be familiar with modern construction equipment and contract conditions. The candidate should have a thorough understanding and experience with IS code / NBC Guidelines relating to building construction.

A-3. The Bidder shall provide competent personnel for the project execution and supervision who shall be managed by the Lead Project Engineer at site in performing the assignment under this contract.

The Bidder's personnel should have the required experience and expertise in conducting similar type of works with highest professional standards.

The Bidder is required to set-up the site office at the work site and make their own arrangements for the accommodation, furniture and equipment etc.

The project execution and supervision personnel should be mobilized from the date of commencement of works by the Bidder. During the defects liability period, the Bidder would be expected to provide technical advisory services on an "as required" basis. No office set-up is expected to be provided by the Bidder.

After award of the contract, the client expects all of the proposed personnel to be available during implementation of the contract.

A-4. It is the duty of the Bidder (Contractor) to;

1. ensure that high quality of construction is achieved
2. ensure that all works are carried out in full compliance with the Engineering design, technical specifications and contract documents;

3. check / conduct all necessary measurements, tests, and control the quality of various items of works and in accordance with the relevant code of Building specification with the latest edition.

B. CONTRACT MANAGEMENT FRAMEWORK

B-1. The execution of the works shall be governed by the Contract Management Framework (CMF).

The main features of CMF are described in the paragraphs that follow.

To administer the contracts under the project, the Divisional Forest Officer, Puri Wildlife Division Odisha will be the Contractual "**Employer**".

The Assistant Conservator of Forest shall be the Assistant Conservator of Forests" of the respective Project sites and will work as the representative of the Employer. Consultant if required may be engaged as "Supervisor", who may on proper authority, work as the representative of the employer for the purpose of supervision.

The Bidder shall be termed as Contractor for the project in accordance with Odisha PWD Code.

The Divisional Forest Officer, Puri Wildlife Division Odisha will define the objectives of the project, and ensure that the execution is within the scope defined in the objectives.

The Divisional Forest Officer, Puri Wildlife Division Odisha in particular to sanction variation orders, including variation in quantities and additional work items proposed by the Bidder, and all other items requiring specific approval from the Employer by following procedures as per OPWD code.

The Divisional Forest Officer, Puri Wildlife Division Odisha shall take approval of Government in accordance with Rules of OPWD Code where ever necessary.

B-2. DUTIES AND RESPONSIBILITIES OF THE DIVISIONAL FOREST OFFICER OR OFFICER-IN-CHARGE

The duties of the Officer in Charge are to administer the works contract and ensure that the contractual clauses, whether related to quality or quantities of work, are respected. The duties of the Divisional Forest Officer include issuing of decisions; certificates and orders as specified in details in the construction contract documents. The Divisional Forest Officer will also co-ordinate the teams, to ensure that the technical policies are correctly and consistently implemented.

The principal responsibilities of the Divisional Forest Officer will be, but not be limited to, the following:

- (a) to give the order to commence the works;
- (b) to inspect Bidder's plant and equipments and recommend augmentation/ rectification of deficiencies, if required
- (c) to order special tests of materials and/or completed works, and/or order removal and substitution of improper materials and/or the works as required;
- (d) approve and/or issue working drawings including variations thereof arising out of change in design as per site requirements

- (e) monitor and verify the correctness of the "as-built" drawings supplied by the Bidder;
- (f) to monitor the progress of the works;
- (g) to review all the test result/ certificates of all construction materials and inspect sources of materials to establish their quality suitable to the required standard.
- (h) to check all bituminous mix designs and concrete mix design proposed by the Bidder where ever required and in due time and suggest modifications in the mix design, laying methods, sampling and testing procedure and quality control measures, to ensure required standard and consistency in quality at the commencement of times;
- (i) to check and certify the laboratory and field tests carried out by the Bidder and also carry out independent tests, if required. The report of such test shall be submitted to the Divisional Forest Officer-in- Charge within a period of 7 days of such tests.
- (j) to issue completion certificate of part or all the works;
- (k) to inspect the works during the construction period and the Defects Liability Period, and to issue Defects Liability Certificates after rectification by the Bidder of defects notified to him by the Divisional Forest Officer;
- (l) to advise the Employer on all matter relating to execution of the works and claims from the Bidder, and to make recommendations thereon, including the possible recourse to arbitration;
- (m) to approve the setting out the works;
- (n) to approve materials and sources of materials;
- (o) to instruct the removal from the site of materials which are not as per specifications or reconstruction of parts of the works which do not comply with the specification;
- (p) to issue monthly progress reports;
- (q) to issue interim payment certificates for works carried out by the Bidder, and certify completion of parts or the totality of the works (payments are to be recorded in the measurement book before issue of interim certificates);
- (r) to assist the Employer in providing clarification/explanation to observations made, from time to time by the Accountant General's office/Auditors.

B-3. ACTIONS REQUIRING SPECIFIC APPROVAL OF THE EMPLOYER

The **Supervisor** will be required to obtain the specific approval of the Employer before taking any of the following actions:

- a) approving subcontracting of any parts of the Works;
- b) certifying additional cost;
- c) determining an extension of time;
- d) issuing a variation order, except
 - i. in an emergency situation, as reasonably determined by the Divisional Forest Officer as per OPWDCode.
 - ii. when there is no financial impact;
- e) fixing rates or prices;
- f) approving programme for execution of works; and,
- g) suspension of works

B-4. DUTIES & RESPONSIBILITIES OF THE LEAD PROJECT ENGINEER

The duties of the Lead Project Engineer of the bidder (Contractor) are, to supervise construction of the works and, to test and examine any material to be used or workmanship employed in connection with the works. The principal responsibilities of the Lead Project Engineer of the bidder (Contractor) are likely to be as follows:

1. to ensure that the construction work is accomplished in accordance with the technical specifications and Contract Condition;
2. to identify construction problems and delays and to recommend to the Divisional Forest Officer, actions to expedite progress
3. to ensure proper keeping of records
4. to monitor and check the day-to-day quality control and quantity measurements of the work carried out under the Contract and prepare the monthly payment certificates.
5. to prepare in consultation with the Employer, a Construction Supervision Manual outlining routine and procedures to be applied in contract management, construction supervision and administration;
6. to prepare a maintenance manual outlining the routines to be adopted in each specific reach and for the cross-drainage works and buildings;
7. to comply with his contractual obligations in executing work in all matters concerning safety and care of the works (including the erection of temporary signs) and, if required, to request the Bidder to provide any necessary lights, guards, fencing and watchmen for smooth and effective working and traffic flow.
8. to write a day-by-day project diary which shall record all events pertaining to the administration of the contract, request forms and orders given to the Bidder, and any other information which may at a later date be of assistance in resolving queries which may arise concerning execution of the works;

C) DATA, SERVICES AND FACILITIES TO BE PROVIDED BY THE EMPLOYER

Attention is drawn to the following which are **not provided by the Employer** and are to be arranged by the Bidder at his own cost.

- ❖ The Government of Odisha will not provide office accommodation. The Bidder shall make his own office accommodation arrangements for their office staff for each of the field supervision teams including furniture, equipment, operation and maintenance.
- ❖ The Government of Odisha will not provide project vehicles to the Bidder. The Bidder shall make his own arrangements in respect of vehicles. The Bidder shall ensure that vehicles for the team are of good makes and are of excellent working condition.
- ❖ The Bidder shall be responsible for making his own arrangements for survey equipment.
- ❖ The Bidder shall be responsible for making his own arrangements for communications.

Site Laboratories: The site laboratories (including furniture, equipment, running and maintenance) shall be provided by the Bidder, the cost of which is inclusive in this turn-key contract. The laboratory equipment shall be as specified and as required by the Employer.

D-1 . REPORTING REQUIREMENTS

The Lead Project Engineer of the bidder (Contractor) in charge of the building site shall prepare and submit to the Divisional Forest Officer five copies each of the following reports:

(i) Monthly Reports: The Lead Project Engineer of the bidder (Contractor) shall, no later than the 10th of each month, prepare a brief progress report summarizing the progress of the construction contract. The report shall outline any problem encountered (administrative, technical or financial) and give recommendations on how these problems may be overcome. The report should record the status of payment.

(ii) Quarterly/Annual Reports: The Lead Project Engineer of the bidder (Contractor) shall prepare a comprehensive report summarizing all activities annually. Such reports shall summarize the progress of the Contract, all contract variations and change orders, the status of Bidder claims, if any, brief descriptions of the technical and contractual problems encountered and Divisional Forest Officer's / Employer's suggestions on how to overcome those, financial status of the Contract as a whole consisting of the costs incurred and costs forecast, as well as financial plan (by the Employer) and other relevant information for the ongoing Contract.

(iii) Sectional/Final Completion Report: The Lead Project Engineer of the bidder (Contractor) shall prepare a comprehensive Final Completion Report for the Contract when it reaches a stage of substantial completion during the period of the services. Completion Reports must also be submitted immediately after the taking over of each Section or part of the Permanent Works. The Reports shall summarize the method of construction and supervision and recommendations for future projects of similar nature to be undertaken by the employer.

Besides the above, five copies each of Construction Supervision and Maintenance Manuals are to be submitted along with the Final Completion Report.

D -2. DOCUMENTS PREPARED SHALL BE THE PROPERTY OF THE EMPLOYER

All plans, drawings, specifications, designs, reports and other documents (both computer hard copies and soft copies) prepared by the Bidder in performing the works shall become and remain the property of the Employer, and the Bidder shall, not later than upon termination or expiration of this Contract, deliver all such documents to the Client, together with a detailed inventory thereof. The Bidder may retain a copy of such documents but shall not use these documents for purposes unrelated to this Contract without the prior written approval of the Client.

E-1. PAYMENT SCHEDULE

Out of the agreement amount, the design including preparation of DPR cost shall be 4% and construction cost 96%. The client shall effect payments to Bidder in accordance with the following schedule.

| SI No | Activity | Payment as % of Agreement Cost |
|-----------|--|--------------------------------|
| 1. | Design Stage | 4% |
| | a) On approval of inception report & details survey and architectural drawing approved by concerned development authorities -20% | 0.8% |
| | b) On approval of structural design - 30% | 1.2% |
| | c) On approval of Final Architectural drawing showing electrical and sanitary layout plan and detail structural design and interior design / decoration - 20% | 0.8% |
| | d) On Completion of Construction - 30% | 1.2% |
| | Total = | 4% |
| 2. | Construction Stage | 96% |
| | a) On completion upto plinth @ sqft. Each | 10% |
| | b) On completion civil structural work @ sqft. Each | 20% |
| | c) On completion of <ul style="list-style-type: none"> ▪ Brickwork / Masonry work @ sqft. 3.75% ▪ Internal plaster @ sqft. 2.75% ▪ External plaster @ sqft. 2% ▪ False Ceiling @ sqft. 2.5% ▪ Floor Finish @ nos. 5% ▪ External Finish @ nos. 4% ▪ Doors & Windows @ nos. 1% ▪ Internal finishing @ sqft. 5% | 26% |
| | d) On completion of <ul style="list-style-type: none"> ▪ Electrical installation @ 8% ▪ Furnishing including supply of furniture as per drawings 8% ▪ Fire Fighting System @ nos. 2% ▪ HVAC including DG set, Inverter @ 4% | 22% |
| | e) On completion of <ul style="list-style-type: none"> ▪ PH works (water supply & sanitation) 10% ▪ Hot water, Solar System @ nos. 2% | 12% |
| | f) External development work like parking, landscaping, area lighting, including finishing, final approval from competent authority viz. development authority and GRIHA, testing, commissioning with approval from authority like fire officer and completion of all items as per approval. | 6% |
| | Total = | 96% |
| | Grand Total = | 100% |
| | | 100% |

E-2. PROCEDURE FOR PAYMENT

The Bidder shall submit all bills to the Divisional Forest Officer though officer in-charge who will process the bills for payment after due scrutiny of work actually completed by a committee formed for this purpose including their quality aspects as per the latest IRC/NBC/ BIS guidelines.

However, in no case, the total cost of payment shall exceed the Lump Sum Contract Value for which the agreement is signed except change in scope, compensation or bonus etc. as admissible as per the contract.

Detail Project / Work accounts will be kept by the concerned Divisional Accountant, who shall perform his duties as per rules of OPWD Code. All bills furnished by the bidder shall be routed through the Divisional Accountant to the Divisional Forest Officer for payment.

Annexure to Payment Schedule

Annexure – A

| Clause E-1 Payment Schedule of Section-9 | | | | | |
|--|---|--|---------------------------------|-------|-----------|
| 1 | | design stage | 4% | | |
| | a | On approval of Inception Report & details survey and architectural drawing approved by concerned development authorities | | 20% | 0.800% |
| | b | On approval of structural plan | | 30% | 1.200% |
| | c | On approval of final Architectural drawing showing electrical and sanitary lay out plan and structural design and interior design/decoration | | 20% | 0.800% |
| | d | On completion of construction | | 30% | 1.200% |
| | | | | | 4% |
| 3 | | Construction Stage | 96% | | |
| | a | On completion up to plinth @sqft each | | 10% | 10% |
| | b | On completion of civil structural work @sqft each | | | |
| | | On completion of columns work @sqft each | | 40% | 8% |
| | | On completion of slab work @sqft each | | 60% | 12% |
| | c | On completion of | | | |
| | | i | Brick work / Masonry work @ sft | 3.75% | 26.00% |
| | | ii | Internal Plaster@ sft | 2.75% | |
| | | iii | External Plaster @ sft | 2% | |
| | | iv | False ceiling @ sft | | |
| | | | Supply | 70% | 1.75% |
| | | | Erection | 30% | 0.75% |
| | | v | Floor Finish @ sft | | |
| | | | Supply | 70% | 3.5% |
| | | | Erection | 30% | 1.5% |
| | | vi | External Finish @ nos | | |
| | | | Paint Primer | | 1% |
| | | | Paint 1st coat | | 1% |
| | | | Paint second coat | | 1% |
| | | | Roof waterproofing | | 1% |
| | | vii | Doors and Windows @ | | |

| | | | | | | |
|--|----------|-------------------------|--|-----|-------|--------|
| | | | nos | | | |
| | | | Supply | 70% | 0.70% | |
| | | | Erection | 30% | 0.30% | |
| | | viii | Internal finishing @ sft | | | |
| | | | Hand Rail | | 1.25% | |
| | | | Internal water proofing | | 1.75% | |
| | | | Internal paint | | 2.00% | |
| | | | | | | |
| | d | On completion of | | | | |
| | | | i Electrical installation @ | | | 22.00% |
| | | | Conduit pipe, junction boxes | | | |
| | | | Supply | 75% | 0.75% | |
| | | | Erection | 25% | 0.25% | |
| | | | Internal wiring and accessories | | | |
| | | | Supply | 75% | 1.13% | |
| | | | Erection | 25% | 0.38% | |
| | | | Transformer testing, installation complete | | | |
| | | | Supply | 75% | 1.13% | |
| | | | Erection | 25% | 0.38% | |
| | | | Earthing & lightning arresters | | | |
| | | | Supply | 75% | 0.75% | |
| | | | Erection | 25% | 0.25% | |
| | | | Cable, Cable trays/trench | | | |
| | | | Supply | 75% | 0.75% | |
| | | | Erection | 25% | 0.25% | |
| | | | Electrical Fittings | | | |
| | | | Supply | 75% | 0.75% | |
| | | | Erection | 25% | 0.25% | |
| | | | Panel | | | |
| | | | Supply | 75% | 0.75% | |
| | | | Erection | 25% | 0.25% | |
| | | | ii Installation of furniture @ nos | | | |
| | | | Supply | 75% | 6% | |
| | | | Erection | 25% | 2% | |
| | | | | | | |
| | | | iii Fire Fighting | | | |

| | | | | | |
|----------|-------------------------|-----------|--|-----|--------|
| | | | System @ nos | | |
| | | | Pumps | | |
| | | | Supply | 75% | 0.75% |
| | | | Installation | 25% | 0.25% |
| | | | Pipe & Accessories | | |
| | | | Supply | 75% | 0.75% |
| | | | Installation | 25% | 0.25% |
| | | | | | |
| | | iv | HVAC including DG Set, Inverter @ | | |
| | | | HVAC | | |
| | | | Chillers & Pumps | | |
| | | | Supply | 75% | 0.75% |
| | | | Installation | 25% | 0.25% |
| | | | Ducting & Piping | | |
| | | | Supply | 75% | 0.75% |
| | | | Installation | 25% | 0.25% |
| | | | DG set | | |
| | | | Supply | 75% | 1.50% |
| | | | Installation | 25% | 0.50% |
| | | | | | |
| e | On completion of | | | | |
| | | i | PH works (water supply & sanitation) | | 10.00% |
| | | | Supply of Water supply pipe | | 2.00% |
| | | | Fitting, fixing of pipes with accessories | | 0.50% |
| | | | Supply of waste water and soil pipe | | 1.50% |
| | | | Fitting, fixing of soil pipes with accessories | | 0.50% |
| | | | Pump | | |
| | | | Supply | | 0.75% |
| | | | Installation | | 0.25% |
| | | | Valve and accessories | | 1.50% |
| | | | Sanitary and CP fixtures supply | | 1.50% |
| | | | Sanitary and CP | | 0.50% |

| | | | | | | |
|--|---|---|---|--|-------|-------|
| | | | fixtures Installation | | | |
| | | | Commissioning & testing | | 1.00% | |
| | | | | | | |
| | | ii | Hot water, Solar system | | | |
| | | | Supply | | 1.50% | 2.00% |
| | | | Installation | | 0.50% | |
| | | | | | | |
| | f | External development work like parking, landscaping, area lighting, including finishing, final approval from competent authority and GRIHA, testing, commissioning with approval from authority like fire officer and completion of all items as per approval | | | | |
| | | | Commissioning & testing Transformer, DG set, Electrical systems, PH systems, HVAC | | | |
| | | | Parking | | 0.50% | 6.00% |
| | | | Landscaping | | 1.00% | |
| | | | Area lighting | | 0.50% | |
| | | | Approval from Competent authority | | 1.0% | |
| | | | GRIHA rating | | 1.0% | |
| | | | Approval from Fire Deptt | | 1.0% | |
| | | | Completion /Occupanc y | | 1.0% | |

APPENDIX -I

FORMAT FOR POWER OF ATTORNEY FOR SIGNING OF APPLICATION

(REFER CLAUSE 4.3.5)

Know all men by these presents, We..... (name of the firm and address of the registered office) do hereby irrevocably constitute, nominate, appoint and authorise Mr/ Ms (name), son/daughter/wife of and presently residing at, who is presently employed with us/ the Lead Member of our Joint Venture and holding the position of , as our true and lawful attorney (hereinafter referred to as the “Attorney”) to do in our name and on our behalf, all such acts, deeds and things as are necessary or required in connection with or incidental to submission of our application for qualification and submission of our bid for the **(Name of the project to be inserted)** on **Turnkey Project** proposed or being developed by the **Works Department, Govt. of Odisha** through the **Divisional Forest Officer, Puri Wildlife Division, Odisha**(the “Employer”) including but not limited to signing and submission of all applications, bids and other documents and writings, participate in Pre-Applications and other conferences and providing information/ responses to the Employer, representing us in all matters before the Employer, signing and execution of all contracts including the **Turnkey Project** and undertakings consequent to acceptance of our bid, and generally dealing with the Employer in all matters in connection with or relating to or arising out of our bid for the said Project and/ or upon award thereof to us and/or till the entering into of the **Turnkey Project** with the Employer.

AND we hereby agree to ratify and confirm and do hereby ratify and confirm all acts, deeds and things done or caused to be done by our said Attorney pursuant to and in exercise of the powers conferred by this Power of Attorney and that all acts, deeds and things done by our said Attorney in exercise of the powers hereby conferred shall and shall always be deemed to have been done by us.

IN WITNESS WHEREOF WE,, THE ABOVE NAMED PRINCIPAL HAVE EXECUTED THIS POWER OF ATTORNEY ON THIS DAY OF 2.....

For

(Signature, name, designation and address)

Witnesses:

1.

(Notarised)

2.

Accepted

.....

(Signature)

(Name, Title and Address of the Attorney)

Notes:

- *The mode of execution of the Power of Attorney should be in accordance with the procedure, if any, laid down by the applicable law and the charter documents of the executant(s) and when it is so required, the same should be under common seal affixed in accordance with the required procedure.*
- *Wherever required, the Applicant should submit for verification the extract of the charter documents and documents such as a board or shareholders' resolution/ power of attorney in favour of the person executing this Power of Attorney for the delegation of power hereunder on behalf of the Applicant.*

APPENDIX II

FORMAT FOR POWER OF ATTORNEY FOR LEAD MEMBER OF JOINT VENTURE

(Refer Clause 4.3.5)

Whereas the **Divisional Forest Officer, Puri Wildlife Division, Odisha** (“the Employer”) has invited applications from interested parties for the **(Name of the project to be inserted)** on Turnkey Project(the “Project”).

Whereas,,, and (collectively the “Joint Venture”) being Members of the Joint Venture are interested in bidding for the Project in accordance with the terms and conditions of the Standard Bidding Document (SBD) and other connected documents in respect of the Project, and

Whereas, it is necessary for the Members of the Joint Venture to designate one of them as the Lead Member with all necessary power and authority to do for and on behalf of the Joint Venture, all acts, deeds and things as may be necessary in connection with the Joint Venture’s bid for the Project and its execution.

NOW THEREFORE KNOW ALL MEN BY THESE PRESENTS

We, having our registered office at, M/s. having our registered office at, M/s. having our registered office at, and having our registered office at, (hereinafter collectively referred to as the “Principals”) do hereby irrevocably designate, nominate, constitute, appoint and authorise M/S having its registered office at, being one of the Members of the Joint Venture, as the Lead Member and true and lawful attorney of the Joint Venture (hereinafter referred to as the “Attorney”). We hereby irrevocably authorise the Attorney (with power to sub-delegate) to conduct all business for and on behalf of the Joint Venture and any one of us during the bidding process and, in the event the Joint Venture is awarded the contract, during the execution of the Project and in this regard, to do on our behalf and on behalf of the Joint Venture, all or any of such acts, deeds or things as are necessary or required or incidental to the qualification of the Joint Venture and submission of its bid for the Project, including but not limited to signing and submission of all applications, bids and other documents and writings, participate in bidders and other conferences, respond to queries, submit information/ documents, sign and execute contracts and undertakings consequent to acceptance of the bid of the Joint Venture and generally to represent the Joint Venture in all its dealings with the Employer, and/ or any other Government Agency or any person, in all matters in connection with or relating to or arising out of the Joint Venture’s bid for the Project and/ or upon award thereof till the EPC Contract is entered into with the Employer.

AND hereby agree to ratify and confirm and do hereby ratify and confirm all acts, deeds and things done or caused to be done by our said Attorney pursuant to and in exercise of the powers conferred by this Power of Attorney and that all acts, deeds and things done by our said Attorney in exercise of the powers hereby conferred shall and shall always be deemed to have been done by us/ Joint Venture.

Appendix II

Page 2

IN WITNESS WHEREOF WE THE PRINCIPALS ABOVE NAMED HAVE EXECUTED THIS POWER OF ATTORNEY ON THIS DAY OF2.....

For
(Signature)

.....
(Name & Title)

For
(Signature)

.....
(Name & Title)

For
(Signature)

.....
(Name & Title)

Witnesses:

1.

2.

.....

(Executants)

(To be executed by all the Members of the Joint Venture)

Notes:

- *The mode of execution of the Power of Attorney should be in accordance with the procedure, if any, laid down by the applicable law and the charter documents of the executant(s) and when it is so required, the same should be under common seal affixed in accordance with the required procedure.*
- *Also, wherever required, the Applicant should submit for verification the extract of the charter documents and documents such as a board or shareholders' resolution/ power of attorney in favour of the person executing this Power of Attorney for the delegation of power hereunder on behalf of the Applicant.*

APPENDIX III
FORMAT FOR JOINT BIDDING AGREEMENT FOR JOINT VENTURE

*(Refer Clause 4.3.6)
(To be executed on Stamp paper of appropriate value)*

THIS JOINT BIDDING AGREEMENT is entered into on this the day of20...

AMONGST

1. {..... Limited, a company incorporated under the Companies Act, 1956} and having its registered office at (hereinafter referred to as the “**First Part**” which expression shall, unless repugnant to the context include its successors and permitted assigns)

AND

2. {..... Limited, a company incorporated under the Companies Act, 1956} and having its registered office at (hereinafter referred to as the “**Second Part**” which expression shall, unless repugnant to the context include its successors and permitted assigns)

WHEREAS,

- (A) THE **Divisional Forest Officer, Puri Wildlife Division**, and having its offices at Office of the E.I.C. (Civil), Nirman Soudh, Unit-V, Bhubaneswar, Odisha (hereinafter referred to as the “**Employer**” which expression shall, unless repugnant to the context or meaning thereof, include its administrators, successors and assigns) has invited applications (the “**Applications**”) by its Invitation for Bids (IFB) with Bid Identification No. dated(the “**SBD**”) for qualification of bidders (**Name of the project to be inserted**) on Turnkey Project (the “**Project**”) through a Turnkey Contract.
- (B) The Parties are interested in jointly bidding for the Project as members of a Joint Venture and in accordance with the terms and conditions of the Bid document and other bid documents in respect of the Project, and
- (C) It is a necessary condition under the Bid document that the members of the Joint Venture shall enter into a Joint Bidding Agreement and furnish a copy thereof with the Application.

NOW IT IS HEREBY AGREED as follows:

1. Definitions and Interpretations

In this Agreement, the capitalised terms shall, unless the context otherwise requires, have the meaning ascribed thereto under the Bid.

2. Joint Venture

- 2.1 The Parties do hereby irrevocably constitute a Joint Venture (the “**Joint Venture**”) for the purposes of jointly participating in the Bidding Process for the Project.
- 2.2 The Parties hereby undertake to participate in the Bidding Process only through this Joint Venture and not individually and/ or through any other Joint Venture constituted for this Project, either directly or indirectly.

3. Covenants

The Parties hereby undertake that in the event the Joint Venture is declared the selected Bidder and awarded the Project, it shall enter into an Turnkey Contract with the Employer for performing all its obligations as the Contractor in terms of the Turnkey Contract for the Project.

4. Role of the Parties

The Parties hereby undertake to perform the roles and responsibilities as described below:

- (a) Party of the First Part shall be the Lead member of the Joint Venture and shall have the power of attorney from all Parties for conducting all business for and on behalf of the Joint Venture during the Bidding Process and until the Appointed Date under the Turnkey Contract;
- (b) Party of the Second Part shall be {the Member of the Joint Venture; and}

5. Joint and Several Liability

The Parties do hereby undertake to be jointly and severally responsible for all obligations and liabilities relating to the Project and in accordance with the terms of the Bid and the Turnkey Contract, till such time as the completion of the Project is achieved under and in accordance with the Turnkey Contract.

6. Share of work in the Project

The Parties agree that the proportion of construction in the Turnkey Contract to be allocated among the members shall be as follows:

First Party:

Second Party:

Further, the Lead Member shall itself undertake and perform at least 50 (Fifty) per cent of the total project if the Contract is allocated to the Joint Venture.

7. Representation of the Parties

Each Party represents to the other Parties as of the date of this Agreement that:

- (a) Such Party is duly organised, validly existing and in good standing under the laws of its incorporation and has all requisite power and authority to enter into this Agreement;
- (b) The execution, delivery and performance by such Party of this Agreement has been authorised by all necessary and appropriate corporate or governmental action and a copy of the extract of the charter documents and board resolution/ power of attorney in favour of the person executing this Agreement for the delegation of power and authority to execute this Agreement on behalf of the Joint Venture Member is annexed to this Agreement, and will not, to the best of its knowledge:
 - (i) require any consent or approval not already obtained;
 - (ii) violate any Applicable Law presently in effect and having applicability to it;

- (iii) violate the memorandum and articles of association, by-laws or other applicable organisational documents thereof;
 - (iv) violate any clearance, permit, concession, grant, license or other governmental authorisation, approval, judgement, order or decree or any mortgage agreement, indenture or any other instrument to which such Party is a party or by which such Party or any of its properties or assets are bound or that is otherwise applicable to such Party; or
 - (v) create or impose any liens, mortgages, pledges, claims, security interests, charges or Encumbrances or obligations to create a lien, charge, pledge, security interest, encumbrances or mortgage in or on the property of such Party, except for encumbrances that would not, individually or in the aggregate, have a material adverse effect on the financial condition or prospects or business of such Party so as to prevent such Party from fulfilling its obligations under this Agreement;
- (c) this Agreement is the legal and binding obligation of such Party, enforceable in accordance with its terms against it; and
- (d) there is no litigation pending or, to the best of such Party's knowledge, threatened to which it or any of its Affiliates is a party that presently affects or which would have a material adverse effect on the financial condition or prospects or business of such Party in the fulfilment of its obligations under this Agreement.

8. Termination

This Agreement shall be effective from the date hereof and shall continue in full force and effect until Project completion (the "Defects Liability Period") is achieved under and in accordance with the Turnkey Contract, in case the Project is awarded to the Joint Venture. However, in case the Joint Venture is either not qualified for the Project or does not get selected for award of the Project, the Agreement will stand terminated in case the Applicant is not pre-qualified or upon return of the Bid Security by the Employer to the Bidder, as the case may be.

9. Miscellaneous

- 9.1 This Joint Bidding Agreement shall be governed by laws of {India/Odisha}.
- 9.2 The Parties acknowledge and accept that this Agreement shall not be amended by the Parties without the prior written consent of the Employer.

Appendix III

Page 4

IN WITNESS WHEREOF THE PARTIES ABOVE NAMED HAVE EXECUTED AND DELIVERED THIS AGREEMENT AS OF THE DATE FIRST ABOVE WRITTEN.

SIGNED, SEALED AND DELIVERED

SIGNED, SEALED AND DELIVERED

For and on behalf of

LEAD MEMBER by:

SECOND PART

(Signature)

(Signature)

(Name)

(Name)

(Designation)

(Designation)

(Address)

(Address)

In the presence of:

1.

2.

Notes:

1. The mode of the execution of the Joint Bidding Agreement should be in accordance with the procedure, if any, laid down by the Applicable Law and the charter documents of the executant(s) and when it is so required, the same should be under common seal affixed in accordance with the required procedure.
2. Each Joint Bidding Agreement should attach a copy of the extract of the charter documents and documents such as resolution / power of attorney in favour of the person executing this Agreement for the delegation of power and authority to execute this Agreement on behalf of the Joint Venture Member.
3. Clause Deleted.

Statement of Legal Capacity

(To be forwarded on the letterhead of the Applicant/ Lead Member of Joint Venture)

Ref. Date:

To,

.....
Dear Sir,

We hereby confirm that we/ our members in the Joint Venture (constitution of which has been described in the application) satisfy the terms and conditions laid out in the Bidding document.

We have agreed that (insert member's name) will act as the Lead Member of our Joint Venture.*

We have agreed that (insert individual's name) will act as our representative/ will act as the representative of the Joint Venture on its behalf* and has been duly authorized to submit the Bidding Document. Further, the authorised signatory is vested with requisite powers to furnish such letter and authenticate the same.

Thanking you,

Yours faithfully,

(Signature, name and designation of the authorised signatory)

For and on behalf of.....

**Please strike out whichever is not applicable.*

APPENDIX – V
BANK GUARANTEE FOR BID SECURITY
(Refer Clauses 16.1)

B.G. No.

Dated:

1. In consideration of you, *** **, having its office at *** **, (hereinafter referred to as the “Authority”, which expression shall unless it be repugnant to the subject or context thereof include its, successors and assigns) having agreed to receive the BID of and having its registered office at (and acting on behalf of its JV) (hereinafter referred to as the “Bidder” which expression shall unless it be repugnant to the subject or context thereof include its/their executors, administrators, successors and assigns), for the *** ** Project on [Turnkey] basis (hereinafter referred to as “the Project”) pursuant to the Bid Document dated issued in respect of the Project and other related documents including without limitation the draft contract Agreement (hereinafter collectively referred to as “Bidding Documents”), we (Name of the Bank) having our registered office at and one of its branches at (hereinafter referred to as the “Bank”), at the request of the Bidder, do hereby in terms of Clause 16.1 of the Bidding Document, irrevocably, unconditionally and without reservation guarantee the due and faithful fulfilment and compliance of the terms and conditions of the Bidding Documents (including the Bidding Document) by the said Bidder and unconditionally and irrevocably undertake to pay forthwith to the Authority an amount of Rs. *** ** (Rupees *** ** only) (hereinafter referred to as the “Guarantee”) as our primary obligation without any demur, reservation, recourse, contest or protest and without reference to the Bidder if the Bidder shall fail to fulfil or comply with all or any of the terms and conditions contained in the said Bidding Documents.
2. Any such written demand made by the Authority stating that the Bidder is in default of the due and faithful fulfilment and compliance with the terms and conditions contained in the Bidding Documents shall be final, conclusive and binding on the Bank.
3. We, the Bank, do hereby unconditionally undertake to pay the amounts due and payable under this Guarantee without any demur, reservation, recourse, contest or protest and without any reference to the Bidder or any other person and irrespective of whether the claim of the Authority is disputed by the Bidder or not, merely on the first demand from the Authority stating that the amount claimed is due to the Authority by reason of failure of the Bidder to fulfil and comply with the terms and conditions contained in the Bidding Documents including failure of the said Bidder to keep its BID open during the BID validity period as set forth in the said Bidding Documents for any reason whatsoever. Any such demand made on the Bank shall be conclusive as regards amount due and payable by the Bank under this Guarantee. However, our liability under this Guarantee shall be restricted to an amount not exceeding Rs. *** ** (Rupees *** ** only).
4. This Guarantee shall be irrevocable and remain in full force for a period of 180

(one hundred and eighty) days from the BID Due Date inclusive of a claim period of 60 (sixty) days or for such extended period as may be mutually agreed between the Authority and the Bidder, and agreed to by the Bank, and shall continue to be enforceable till all amounts under this Guarantee have been paid.

5. We, the Bank, further agree that the Authority shall be the sole judge to decide as to whether the Bidder is in default of due and faithful fulfilment and compliance with the terms and conditions contained in the Bidding Documents including, inter alia, the failure of the Bidder to keep its BID open during the BID validity period set forth in the said Bidding Documents, and the decision of the Authority that the Bidder is in default as aforesaid shall be final and binding on us, notwithstanding any differences between the Authority and the Bidder or any dispute pending before any Court, Tribunal, Arbitrator or any other Authority.
6. The Guarantee shall not be affected by any change in the constitution or winding up of the Bidder or the Bank or any absorption, merger or amalgamation of the Bidder or the Bank with any other person.
7. In order to give full effect to this Guarantee, the Authority shall be entitled to treat the Bank as the principal debtor. The Authority shall have the fullest liberty without affecting in any way the liability of the Bank under this Guarantee from time to time to vary any of the terms and conditions contained in the said Bidding Documents or to extend time for submission of the BIDs or the BID validity period or the period for conveying acceptance of Letter of Award by the Bidder or the period for fulfilment and compliance with all or any of the terms and conditions contained in the said Bidding Documents by the said Bidder or to postpone for any time and from time to time any of the powers exercisable by it against the said Bidder and either to enforce or forbear from enforcing any of the terms and conditions contained in the said Bidding Documents or the securities available to the Authority, and the Bank shall not be released from its liability under these presents by any exercise by the Authority of the liberty with reference to the matters aforesaid or by reason of time being given to the said Bidder or any other forbearance, act or omission on the part of the Authority or any indulgence by the Authority to the said Bidder or by any change in the constitution of the Authority or its absorption, merger or amalgamation with any other person or any other matter or thing whatsoever which under the law relating to sureties would but for this provision have the effect of releasing the Bank from its such liability.
8. Any notice by way of request, demand or otherwise hereunder shall be sufficiently given or made if addressed to the Bank and sent by courier or by registered mail to the Bank at the address set forth herein.
9. We undertake to make the payment on receipt of your notice of claim on us addressed to **our branch at Bhubaneswar ([address of Bhubaneswar Branch])** and delivered at our above branch which shall be deemed to have been duly authorised to receive the said notice of claim **& make the payment.**
10. It shall not be necessary for the Authority to proceed against the said Bidder before proceeding against the Bank and the guarantee herein contained shall

be enforceable against the Bank, notwithstanding any other security which the Authority may have obtained from the said Bidder or any other person and which shall, at the time when proceedings are taken against the Bank hereunder, be outstanding or unrealised.

11. We, the Bank, further undertake not to revoke this Guarantee during its currency except with the previous express consent of the Authority in writing.
12. The Bank declares that it has power to issue this Guarantee and discharge the obligations contemplated herein, the undersigned is duly authorised and has full power to execute this Guarantee for and on behalf of the Bank.
13. For the avoidance of doubt, the Bank's liability under this Guarantee shall be restricted to Rs. *** crore (Rupees *** ** crore only). The Bank shall be liable to pay the said amount or any part thereof only if the Authority serves a written claim on the Bank in accordance with paragraph 9 hereof, on or before [*** (indicated date falling 180 days after the BID Due Date)].

Signed and Delivered by Bank

By the hand of Mr./Ms, its and authorised official.

(Signature of the Authorised Signatory)
(Official-Seal)

Sd/-
Divisional Forest Officer, Puri
Wildlife Division, Odisha